



PF93511 Cast Iron Sewage Pump

Product Features

- Rugged cast iron pump body for durability
- SJE Rhombus vertical float switch
- 2" NPT Discharge
- Handles up to 2" solids
- Non-clogging stainless steel vortex impeller
- Carrying handle attached
- 10' power supply cord
- Built-in thermal overload protection for safety
- Permanent split capacitor continuous duty motor
- 7.6 amps, 708 Watts
- 3450 RPM



PF93511

Motor Performance

- 1/2 HP 120 Volt AC (7.6 amps)

Performance Chart						
Lift	0'	5'	10'	15'	20'	25'
GPM	80	68	60	44	13	2
GPH	4800	4080	3600	2640	780	120

Product Specifications

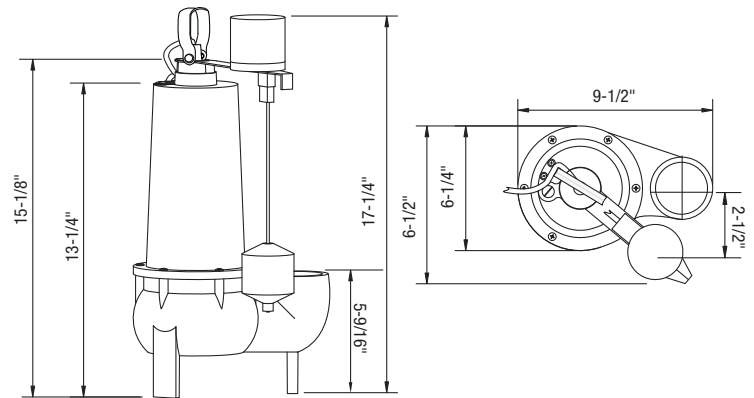

* All measurements are nominal. Please verify before actual installation.

Warranty and Codes

This product comes complete with installation, operating, care and maintenance instructions. This PROFLO sump pump carries a 3 year warranty when installed in residential applications. See owners manual for warranty details.

This PROFLO sump pump carries a 3 year limited warranty. In an effort to continually improve our products, we will make design changes from time to time. We reserve the right to ship newly designed product to fill any order unless it is agreed in writing to do otherwise.

