



PF92305 Cast Iron Effluent Pump

Product Features

- Rugged cast iron pump body for durability
- SJE Rhombus tethered float switch
- 1-1/2" NPT Discharge
- Handles up to 5/8" solids
- Non-clogging vortex impeller
- Carrying handle attached
- 10' power supply cord
- Built-in thermal overload protection for safety
- Permanent split capacitor continuous duty motor
- 5.9 amps, 708 Watts
- 3450 RPM



PF92305

Motor Performance

- 1/3HP 120 Volt AC (5.9 amps)

Performance Chart						
Lift	0'	5'	10'	15'	20'	25'
GPM	60	56	50	35	15	6
GPH	3600	3360	3000	2100	900	360

Product Specifications

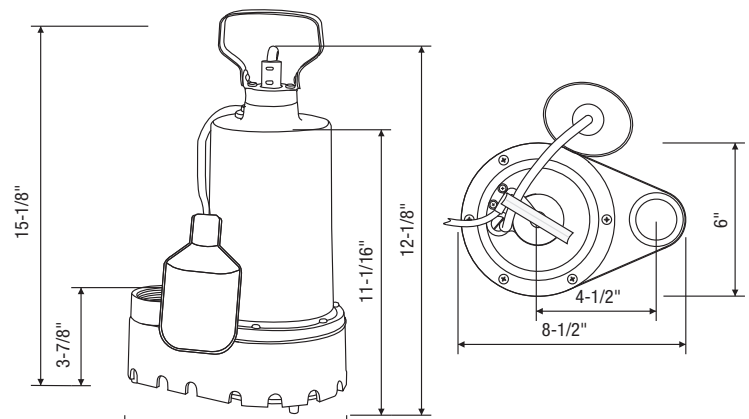

* All measurements are nominal. Please verify before actual installation.

Warranty and Codes

This product comes complete with installation, operating, care and maintenance instructions. This PROFLO sump pump carries a 5 year warranty when installed in residential applications. See owners manual for warranty details.

This PROFLO sump pump carries a 5 year limited warranty. In an effort to continually improve our products, we will make design changes from time to time. We reserve the right to ship newly designed product to fill any order unless it is agreed in writing to do otherwise.

