



300 S. DAYTON ST.
 DAVISON, MI 48423
 PH: 810-653-9626
 FAX: 810-654-2616

1056-43RC

DESCRIPTION:

Connects 4" CI/PL to 3" CI/PL

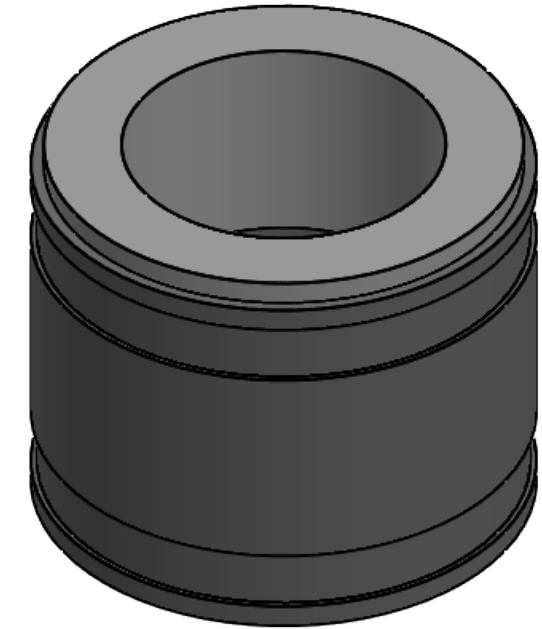
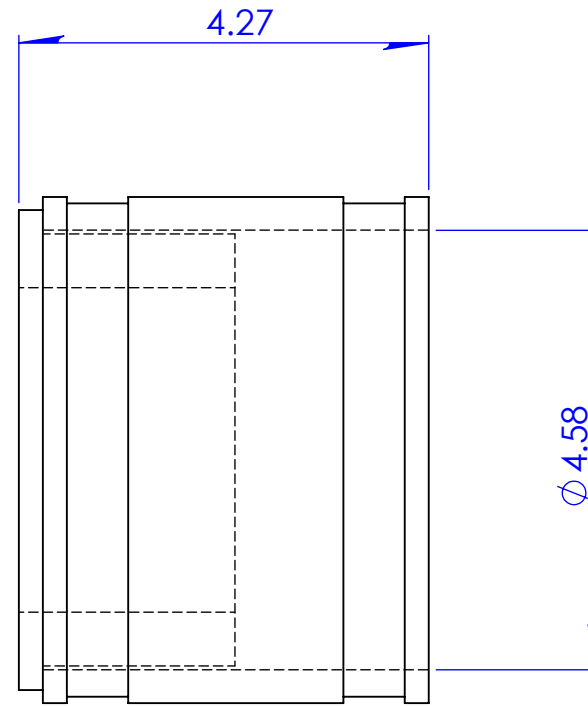
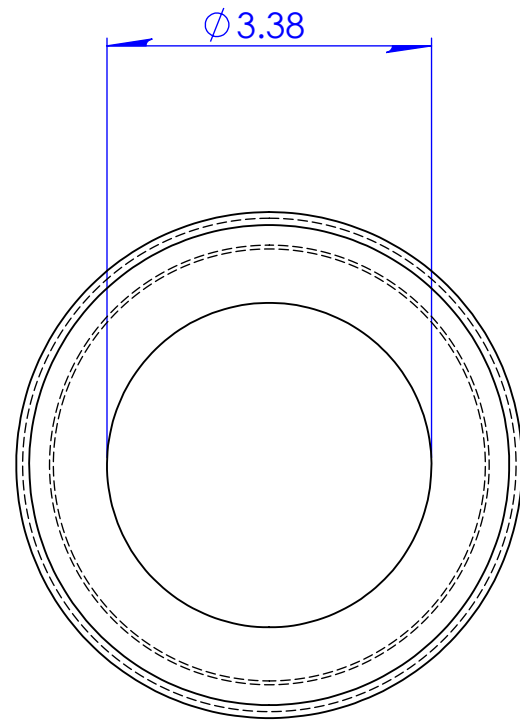

Note:

Shield: SRC-19P
 Reducer: 4.500-3.380R
 *Bands, Clamps and SR
 made from 300 SS*

PROPRIETARY AND CONFIDENTIAL
 THE INFORMATION CONTAINED IN THIS
 DRAWING IS THE SOLE PROPERTY OF
 FERNCO, INC. ANY REPRODUCTION IN
 PART OR AS A WHOLE WITHOUT THE
 WRITTEN PERMISSION OF FERNCO, INC.
 IS PROHIBITED.

TOLERANCES:
 Fractional $\pm 1/4"$
 .XX = $\pm .06$
 ANG. = $\pm 3^\circ$
 UNLESS OTHERWISE SPECIFIED

Part Weight		Installation Torque	60 in lbs	UNITS:	SIZE:	DESIGNER:	SCALE:
Min/Max Temp.	-30/140 Degrees F	ASTM	D5926	INCHES	A	Eli Miller	not to scale
Pressure Tested		Clamps used	300 Series Stainless	3RD ANGLE PROJECTION		CHECKER:	DATE:
Material	Flexible PVC 60 Duro Shore A	Box Quantity		DO NOT SCALE DRAWING			06/12/2017
							SHEET 1 OF 1