

**UPS 50-80/2, 1 ph, 115 V, 230 V, 60 Hz**

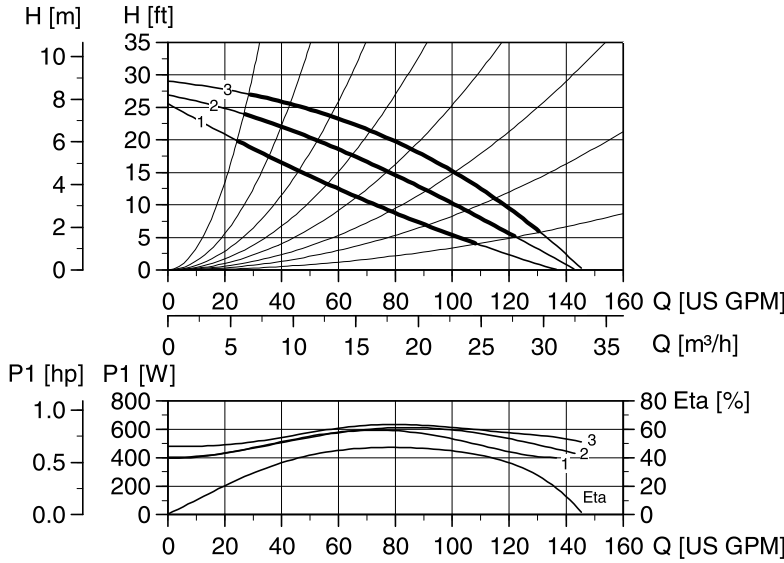

TM00 9520 0697

- Flow range: 20 - 150 gpm
- Head range: 1 - 30 ft
- Motor: 2-pole 0.75 Hp
- Max. liquid temp (Open): +140 °F
- Max. liquid temp.: +248 °F
- Min. liquid temp.: +32 °F
- Max. system pressure: 145 psi
- Net wt: 46.7 lbs (21.2 kg)
- Gross wt.: 54.2 lbs (24.6 kg)
- Shipping volume: 2.90 ft<sup>3</sup> (0.082 m<sup>3</sup>)
- Net wt. bronze: 52.2 lbs (27.3 kg)
- Gross wt. bronze: 59.7 lbs (27.1 kg)
- Shipping volume bronze: 2.90 ft<sup>3</sup> (0.082 m<sup>3</sup>)

**Note:** ETA is calculated as wire-to-water efficiency.

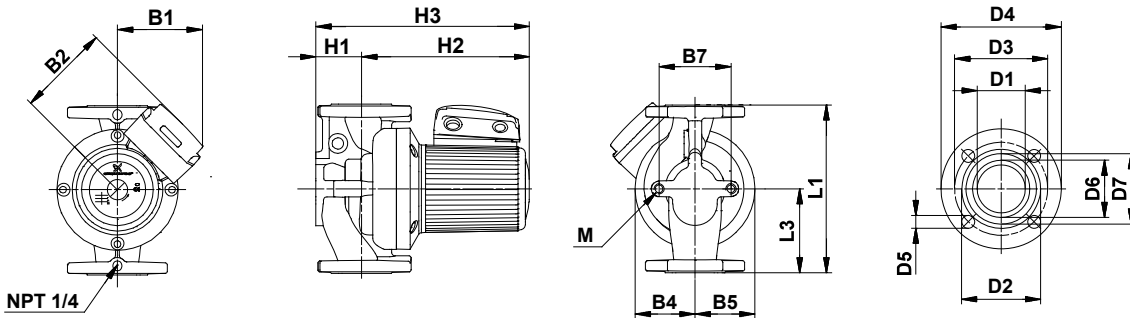

TM02 0730 5100

**Dimensions**

Model	L1	L3	B1	B2	B4	B5	B7	H1	H2	H3	D1	D2	D3	D4	D5	D6	D7	M
UPS 50-80/2	[in]	11.5	7.00	5.31	5.56	3.75	3.00	4.75	3.00	9.88	12.86	2.13	3.44	4.06	5.25	0.55	2.50	3.06
	[mm]	292	178	135	141	95	76	121	76	251	327	54	87	103	133	14	64	78

**Product numbers**

Model type	Product number		Voltage [V]
	Cast Iron	Bronze	
UPS 50-80/2 (1 ph)	96402834	96402843	115
	96402836	96402844	230

**Connections**

Flange size	Flange type
2" non ANSI 4 bolt w/ (4) 0.56" dia. holes	GF 50

**Electrical data**

Speed	Max amps [A]		P Max [Watts]	Start amps [A]	
	115V	230V		115V	230V
3	5.85	2.95	630	14.60	7.30
2	5.80	2.90	610	14.48	7.18
1	5.70	2.85	600	14.23	7.05