

# 9. Curve charts and technical data

UPS 32-40/4, 1 ph, 115 V, 230 V, 60 Hz

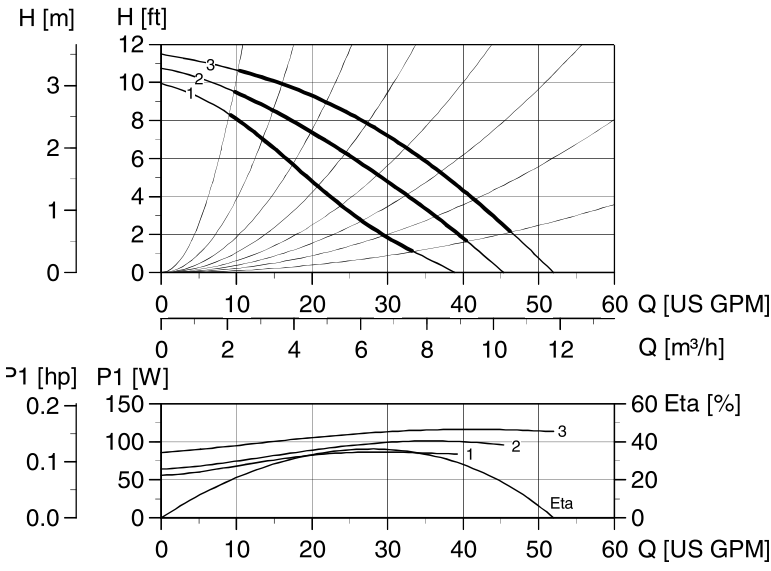

TM00 9510 0697

- Flow range: 9 - 52 gpm
- Head range: 1 - 11 ft
- Motor: 4-pole 0.33 Hp
- Max. liquid temp (Open): +140 °F
- Max. liquid temp.: +248 °F
- Min. liquid temp.: +32 °F
- Max. system pressure: 145 psi
- Net wt: 35.9 lbs (16.3 kg)
- Gross wt.: 43.4 lbs (19.7 kg)
- Shipping volume: 1.70 ft<sup>3</sup> (0.048 m<sup>3</sup>)
- Net wt. bronze: 39.2 lbs (17.8 kg)
- Gross wt. bronze: 46.7 lbs (21.2 kg)
- Shipping volume bronze: 1.70 ft<sup>3</sup> (0.048 m<sup>3</sup>)

Note: ETA is calculated as wire-to-water efficiency.

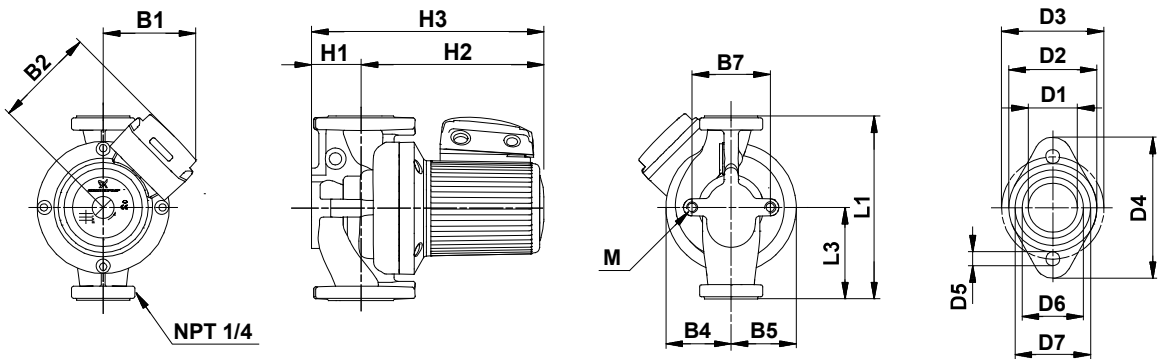

TM02 0729 5100

## Dimensions

Model	L1	L3	B1	B2	B4	B5	B7	H1	H2	H3	D1	D2	D3	D4	D5	D6	D7	M
UPS 32-40/4	[in]	11.00	5.50	5.31	5.56	3.00	3.00	3.19	2.69	9.50	12.24	1.44	2.56	3.14	4.63	1.81	2.25	
	[mm]	279	140	135	141	76	76	81	68	241	311	37	65	80	117	46	57	M12

## Product numbers

Model type	Product number		Voltage [V]
	Cast Iron	Bronze	
UPS 32-40/4 (1 ph)	96402694	96402699	115
	96402695	96402700	230

## Connections

Flange size	Flange type
1.25" non ANSI 2 bolt w/ (2) 0.5" dia. holes	GF 15/26

## Electrical data

Speed	Max amps [A]		P Max [Watts]	Start amps [A]	
	115V	230V		115V	230V
3	1.08	0.54	120	2.10	1.00
2	1.04	0.52	100	2.02	0.96
1	0.95	0.47	85	1.85	0.87