

8110/8111



► **Description**
Exposed, Battery Powered, Sensor Activated, Sloan® Optima® Plus Model Water Closet Flushometer for floor mounted or wall hung top spud bowls.

► **Flush Cycle**
 Model 8111 Low Consumption (1.6 gpf/6.0 Lpf)
 Model 8110 Water Saver (3.5 gpf/13.2 Lpf)

► **Variations**
 TP Trap Primer
 DFB Dual Filtered Fixed Bypass Diaphragm
 YO Bumper on Angle Stop (for open front seat without cover)

► **Specifications**
 Quiet, Exposed, Diaphragm Type, Chrome Plated Closet Flushometer for either left or right hand supply with the following features:

- High Chloramine Resistant PERMEX® Synthetic Rubber Diaphragm with Linear Filtered Bypass and Vortex Cleansing Action™
- ADA Compliant OPTIMA Plus® Battery Powered Infrared Sensor for automatic “No Hands” operation
- Infrared Sensor with Multiple-focused, Lobular Sensing Fields for high and low target detection
- Latching Solenoid Operator
- Engineered Plastic Cover with replaceable Lens Window
- User friendly three (3) second Flush Delay
- Courtesy Flush® Override Button
- Four (4) Size AA Batteries factory installed
- “Low Battery” Flashing LED
- Infrared Sensor Range Adjustment Screw
- Initial Set-up Range Indicator Light (first 10 minutes)
- Chrome Plated Metal Handle Cap
- 1” I.P.S. Screwdriver Bak-Chek® Angle Stop
- Vandal Resistant Stop Cap
- Adjustable Tailpiece
- Vacuum Breaker with Flush Connection
- Spud Coupling and Spud Flange for 1½” Top Spud
- Sweat Solder Adapter with Cover Tube and Cast Wall Flange
- High Copper, Low Zinc Brass Castings for Dezincification Resistance
- No External Volume Adjustment to Ensure Water Conservation
- Low Consumption Flush Accuracy
- Stop Seat and Vacuum Breaker Molded from PERMEX® Rubber Compound for Chloramine Resistance
- 100% of the energy used in manufacturing is offset with Renewable Energy Sources – Wind Energy

- **ADA Compliant**
- **Automatic**
Sloan OPTIMA Plus® equipped Flushometers provide the ultimate in sanitary protection and automatic operation. There is no need for AC hookups or wall alterations. The Flushometer operates by means of a battery powered infrared sensor. Once the user enters the sensor’s effective range and then steps away, the Flushometer Solenoid initiates the flushing cycle to flush the fixture.
- **Hygienic**
User makes no physical contact with the Flushometer surface except to initiate the Override Button when required. Helps control the spread of infectious diseases.
- **Economical**
Automatic operation provides water usage savings over other flushing devices. Reduces maintenance and operation costs.
- **Warranty**
3 year (limited)

Valve Body, Tailpiece and Control Stop shall be in conformance with ASTM Alloy Classification for Semi-Red Brass. Valve shall be in compliance with the applicable sections of ASSE 1037. Installation conforms to ADA requirements.

See Accessories Section and OPTIMA Accessories Section of the Sloan catalog for details on these and other OPTIMA Plus® Flushometer variations.



Listed by I.A.P.M.O.



This space for Architect/Engineer approval

Job Name _____ Date _____

Model Specified _____ Quantity _____

Variations Specified _____

Customer/Wholesaler _____

Contractor _____

Architect _____

The information contained in this document is subject to change without notice.

8110/8111

► Description

Exposed, Battery Powered, Sensor Activated, Sloan® Optima® Plus Model Water Closet Flushometer for floor mounted or wall hung top spud bowls.

► Flush Cycle

- Model 8111 Low Consumption (1.6 gpf/6.0 Lpf)
- Model 8110 Water Saver (3.5 gpf/13.2 Lpf)

ELECTRICAL SPECIFICATIONS

► Control Circuit

Solid State
6 VDC Input
8 second Arming Delay
3 second Flush Delay

► OPTIMA Sensor Type

Active Infrared

► OPTIMA Sensor Range

Nominal 22" - 42" (559 mm - 1067 mm),
adjustable ± 8" (203 mm)

► Battery Type

Four (4) 'AA' Alkaline

► Battery Life

3 years @ 4,000 flushes/month

► Indicator Lights

Range Adjustment/Low Battery

► Operating Pressure

15-100 psi (104-689 kPa)

► Sentinel Flush

Once Every 24 Hours After the Last Flush

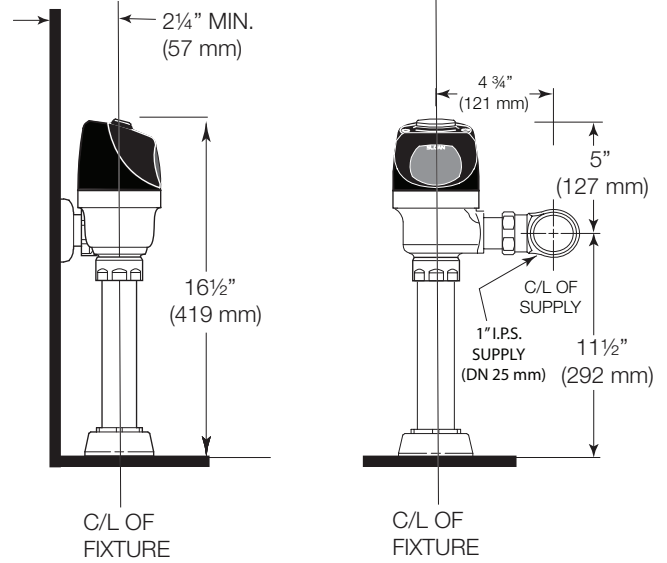

OPERATION

1. A continuous, invisible light beam is emitted from the OPTIMA Plus Sensor.

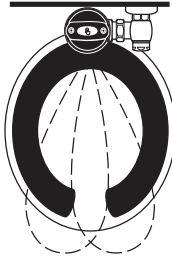

2. As the user enters the beam's effective range (22" to 42") the beam is reflected into the OPTIMA Plus Scanner Window and transformed into a low voltage electrical circuit. Once activated, the Output Circuit continues in a "hold" mode for as long as the user remains within the effective range of the Sensor.

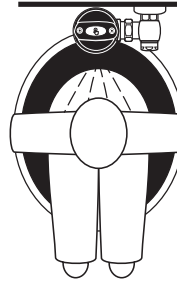

3. When the user steps away from the OPTIMA Plus Sensor, the circuit waits 3 seconds (to prevent false flushing) then initiates an electrical signal that operates the Solenoid. This initiates the flushing cycle to flush the fixture. The Circuit then automatically resets and is ready for the next user.

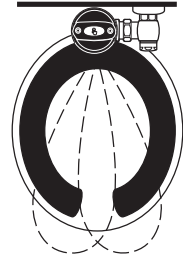

VALVE ROUGH-IN

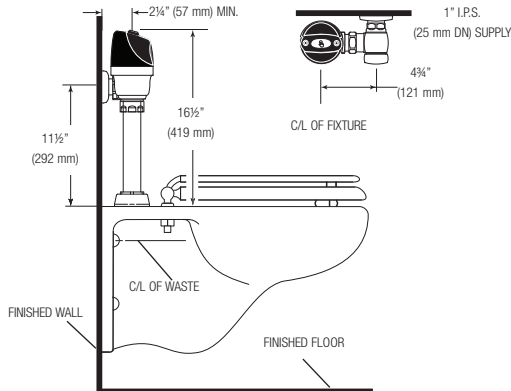

When installing the Optima Plus in a handicap stall:

Per the ADA Guidelines (section 604.9.4) it is recommended that the grab bars be split or shifted to the wide side of the stall.

SLOAN VALVE COMPANY • 10500 SEYMOUR AVENUE • FRANKLIN PARK, IL 60131

Phone: 1-800-9-VALVE-9 or 1-847-671-4300 • Fax: 1-800-447-8329 or 1-847-671-4380 • www.sloanvalve.com