



Hose & Supply Boxes 8292 Series

Wall Frame with Door



8292

Fixture May Show Some Available Options

Please visit www.acorneng.com for most current specifications.

Wall Frame with Door

The Acorn Wall Frame with Door provides an easy access to valves, controls, piping, and equipment with a neat, attractive wall opening.

Wall frame is fabricated entirely from type 304 stainless steel and all exterior surfaces polished to a satin finish. Wall frame is one piece construction without welded corners. Wide beveled flange covers irregularities in the wall opening.

Door includes a cam and cylinder lock with 2 keys. Concealed hinge is mounted in heavy reinforcing channel and allows the door to open full 150 degrees. After door is open, rugged, spring-loaded pivot pins permit quick removal of the door with a screwdriver.

Hose & Supply Boxes 8292 Wall Frame with Door



BASE MODEL NUMBER (Must Specify)

-8292 Wall Frame with Door

Product Options

- LGG Less Logo on Door
- LRD Wall Flange, Less Door

Please visit www.acorneng.com for most current specifications.

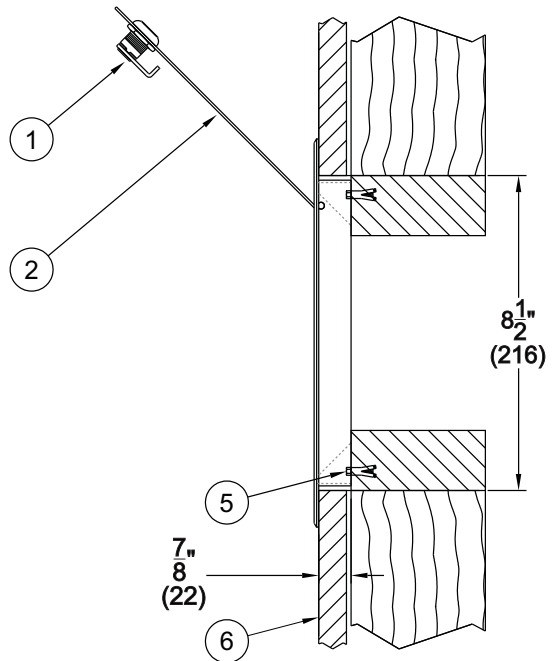
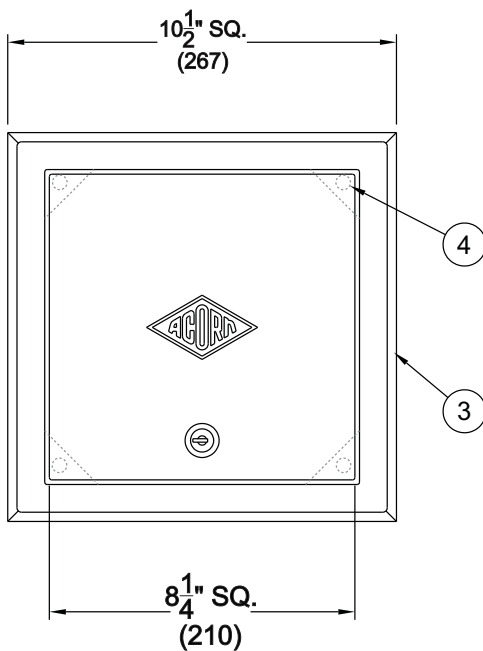

MODEL# 8292

NOTES:

- 1. Cam and Cylinder Lock.
- 2. Removable Door.
- 3. Beveled Flange.
- 4. Mounting Points.
- 5. Hardware by Others.
- 6. Finished Wall.

NOTE: Blocking Can Be Horizontal or Vertical

<p>Important: Installation instructions and current rough-in are furnished with each fixture. Do not rough in without certified dimensions. Dimensions are subject to manufacturer's tolerance of plus or minus 1/4" and change without notice. Acorn assumes no responsibility for use of void or superseded data. © Copyright 2006 Acorn Engineering Company</p>	
<p style="text-align: center;">Selection Summary</p> <p>Model No. & Option _____</p> <p>Quantity _____</p>	<p style="text-align: center;">Approved for Manufacturing</p> <p>Company _____ Title _____</p> <p>Signature _____ Date _____</p>