

Submittal Data Information

Probe Style Low Water Cut-Off - Commercial Hot Water Boilers



Auto Reset Only/Auto Reset-Test Button/Manual Reset-Test Button/Manual Reset Only

Supersedes: NEW

Effective: January 1, 2007

JOB _____ ENGINEER _____ CONTRACTOR _____

Item Number	Model Number	NOTES

Features

- **Low Maintenance** - No moving parts to wear or hang up, as in float devices.
- **More Probe Plate Space** - Large probe tip puts more conductive surface area in the water, leading to more dependable operation and less chance of nuisance boiler shutdowns.
- **Automatic Reset** - Shuts down the burner when water drops below the probe. Automatically recompletes the burner circuit upon return of a safe water level.
- **Manual Reset** - Shuts down the burner when water drops below the probe for 2 seconds. Requires manual reset if the water remains below the probe for 30 seconds. Power failures and air bubbles will not cause the manual reset to lock out. Fully CSD-1 compliant. Lockout will not reset in a power outage.
- **Test Button** - Tests control operation without lowering the water level. Depressing the test button shuts down the burner after two second delay and lights low water indicating LED. Depressing the test button a full 30 seconds will send control into manual reset.

Standard Application

Safgard 170, 500, 600 and 700 Series Low Water Cut-Offs are used as the *primary* low water cut-off on residential and commercial water boilers. The 500 and 700 Series LWCOs are also used as *secondary* controls on commercial steam boilers.

Operation

Hydrolevel controls utilize a non-moving, heavy duty, electronic probe to sense liquid levels. The probe can be installed in an equalizing line or directly into a boiler or water tank in accordance with manufacturers' instructions and local and State codes. When water is in contact with the probe, it completes a circuit between the stainless steel probe tip and the tank or boiler surface in which the probe is installed. When the water level drops below the probe, the circuit opens. Hydrolevel low water cut-offs for hydronic heating systems use the water signal to allow the burner to operate. If the water level drops below the probe, the circuit opens and the cut-off shuts down the burner.

MODEL	VOLTAGE	AUTO RESET	MANUAL RESET	TEST BUTTON	CSD-1 COMPLIANT
24	24VAC	●			
170	120VAC	●			
500	24VAC		●	●	●
550	120VAC		●	●	●
600	24VAC	●		●	
650	120VAC	●		●	
700	24VAC		●		
750	120VAC		●		

Specifications

- **Switch Contacts**.....SPDT
- **Input Voltage**.....24VAC/60HZ or 120VAC/60HZ
- **Alarm Circuit**..50VA@24VAC-Pilot Duty or 125VA@120VAC-Pilot Duty
- **Maximum Pressure**.....250 psi
- **Agency Listing**.....U.L. & CSA
- **Switch Contact Ratings**.....5.8 FLA 34.8 LRA
- **Control Power Consumption**.....3.6 VA
- **NEMA Classification**.....NEMA1

Dimensions

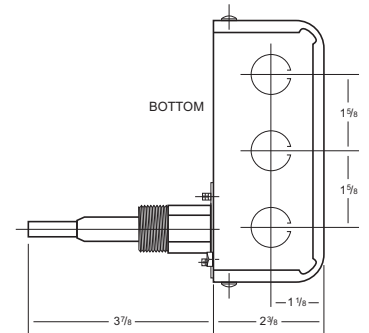
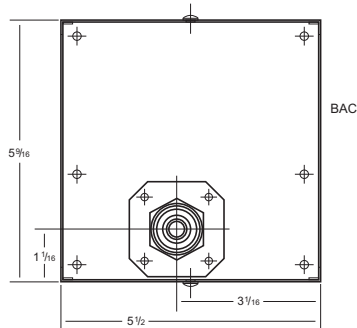

MATERIALS OF CONSTRUCTION	
Control Housing	Galvanized Steel
Probe Insulator	Glazed Ceramic
Probe Tip	316 Stainless Steel
Probe Nut	3/4" or 1/2" NPT Brass



83 Water Street, New Haven, CT 06511
 Phone: (203) 776-0473 • Fax: (203) 773-1019
 email address: info@hydrolevel.com
 Visit our website at:

www.hydrolevel.com