

# spirax/sarco®

## Thermo-Dynamic® Steam Trap TD42

Steam Traps  
Thermo-Dynamic®

The **Thermo-Dynamic®** steam trap cycles periodically to discharge condensate very near to steam temperature. It is unaffected by waterhammer or superheat.

Model	TD42 L	TD42 H
<b>PMO</b>	600 psig	
<b>Sizes</b>	1/2", 3/4", 1"	1/2", 3/4"
<b>Connections</b>	NPT	
<b>Construction</b>	Stainless Steel	
<b>Options</b>	Blowdown valve	

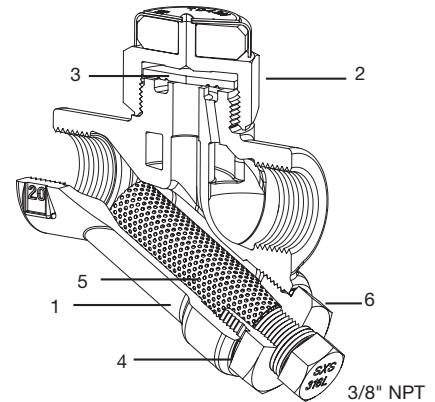

### Limiting Operating Conditions

**Max. Operating Pressure (PMO)** 600 psig (42 barg)  
**Max. Operating Temperature** 752°F (400°C)  
 at all operating pressures

*Minimum pressure for satisfactory operation is 3.5 psi, 0.25 bar.  
 Maximum back pressure should not exceed 80% of the inlet pressure under any conditions of operation, otherwise the trap may not shut.*

### Pressure Shell Design Conditions

**PMA** 914 psig/up to 248°F 63 barg/up to 120°C  
 Max. allowable pressure  
 853 psig/528°F 59 barg/276°C  
 609 psig/752°F 42 barg/400°C

**TMA** 752°F/0-609 psig 400°C/0-42 barg  
 Max. allowable temperature

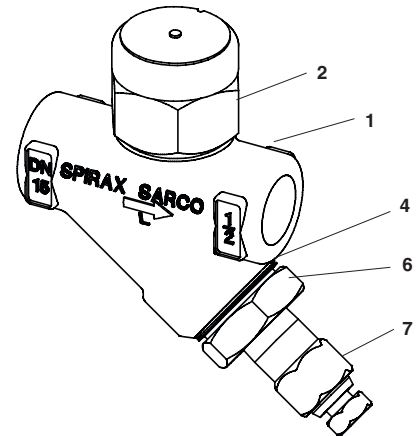

### Typical Applications

Steam main drainage, tracer lines, process equipment, outdoor installations subject to freezing.

### Capacities

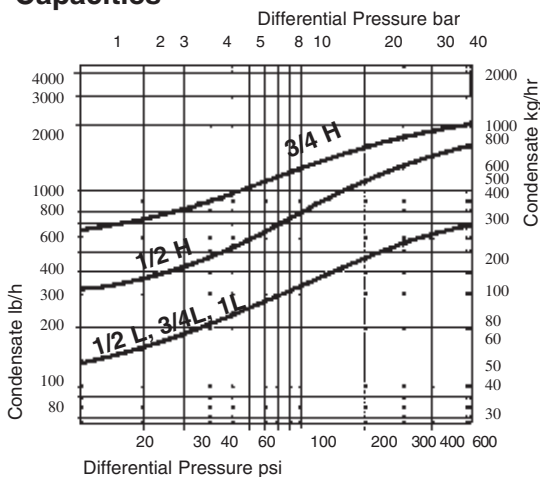

### Construction Materials

No.	Part	Material	
1	Body	Stainless Steel (w/ENP)	ASTM A743 GrCA40F
2	Cap Assembly	Stainless Steel / Ceramic	AISI 416
3	Disc	Stainless Steel	AISI 420
4	Cap Gasket	Stainless Steel	
5	Strainer Screen	Stainless Steel (.031 Perf)	AISI 304
6	Strainer Cap	Stainless Steel	AISI 416
7	Blowdown Valve (optional)	Stainless Steel	

*Local regulation may restrict the use of this product below the conditions quoted. Limiting conditions refer to standard connections only.  
 In the interests of development and improvement of the product, we reserve the right to change the specification.*

TI-2-502-US 05.08

# Thermo-Dynamic® Steam Trap

## TD42

### Dimensions (nominal) in inches and millimeters

TD42L, TD42H								
Size	A	B	C	D	E	Weight lb/kg		
						TD42L	TD42H	
1/2"	2.0 51.5	3.1 78	2.2 55.5	3.7 93	.79 20	1.6 0.78	1.7 0.8	
3/4"	2.1 54.5	3.4 84.4	2.4 61.5	4.1 105	.79 20	1.9 0.93	2.2 1	
1"	2.3 58	3.8 96	2.5 64.5	4.3 109	.79 20	2.4 1.1	–	–
with Blowdown Valve								
1/2"	2.0 51.5	3.1 78	2.8 71	4.3 109	.79 20	2.2 1.0	2.3 1.1	
3/4"	2.1 54.5	3.4 84.4	3.1 80	4.8 122	.79 20	2.65 1.2	2.75 1.25	
1"	2.3 58	3.8 96	3.3 85	5.1 130	.79 20	3.85 1.75	–	–

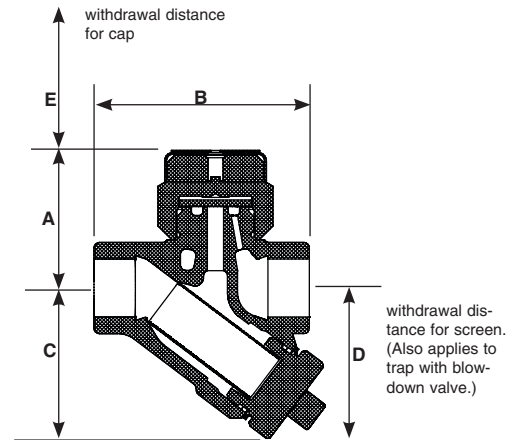

### Options

**Blowdown Valve** – When the blowdown valve is opened, loose material collected by the strainer is blown to atmosphere. Because a wrench is used to open the valve, the operator is clear of the blowdown stream.

### Sample Specification

Steam trap shall be stainless steel thermodynamic type, integral seat design with hardened disc and seating surfaces, and oxidation resistant (ENP) finish. Trap to contain inlet Y strainer, and when required, shall be provided with integral blowdown valve and insulating cover.

### Installation

The trap will operate in any position, but the preferred installation is in a horizontal pipe. Full-port isolating valves should be installed upstream and downstream of the trap.

### Maintenance

This product can be maintained without disturbing the piping connections. Complete isolation of the trap from both supply and return line is required before any servicing is performed.

Although occasional operation of the optional blowdown valve will remove most of the accumulated debris, the trap should be disassembled periodically for cleaning of the strainer screen and inspection and cleaning of the disc and seat.

The only wearing parts of the trap are the disc and seat ring. A worn disc can be replaced, and slight seat ring wear can often be corrected by resurfacing on a lapping plate.

**Complete installation and maintenance instructions are given in an IMI Sheet, available upon request.**

### Spare Parts

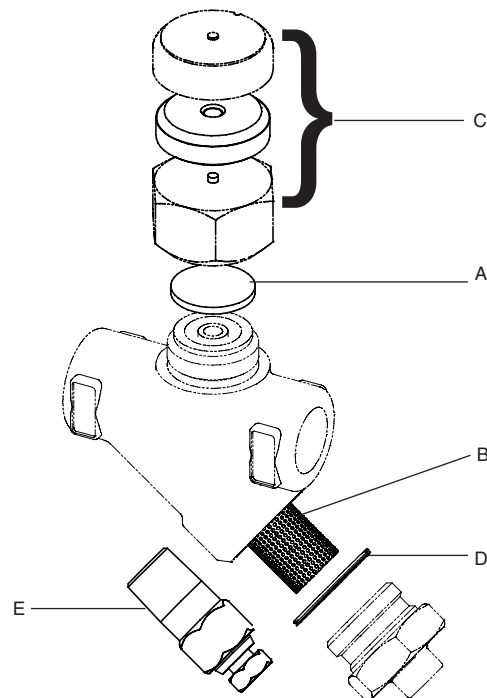

Disc (pkt of 3)	A
Strainer Screen & Gasket	B, D
Insulcap Assembly	C
Gasket (Set of 3)	D
Blowdown Valve	E

Available spare parts are shown in heavy line.  
Parts drawn in broken line are not supplied as spares.