

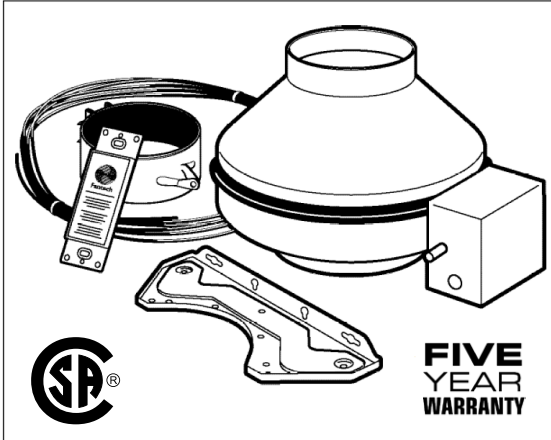

# Fantech

## DBF4XLT

### Dryer Booster Fan



The Fantech DBL4XLT Dryer Booster Fan has been specially designed to solve the problems caused by long duct runs on clothes dryers.

According to dryer manufacturers and some local building codes, booster fans should be added in the dryer duct run when the length of the duct exceeds 24 feet with no bends, 20 feet with one bend or 15 feet with two bends.

#### HOW DOES IT WORK

When the dryer is on, Fantech's patented pressure sensing switch automatically turns the booster fan on. The warm, moist air in the dryer duct is exhausted out of the building quickly.

The dryer booster fan monitors the status of the dryer and will turn itself off when the dryer stops.

Wall mounted indicator panel with LED display lets homeowners know that fan is fully operational.

#### FEATURES

- Inline Dryer Booster Fan featuring self-cleaning backward curved impeller capable of maintaining an air velocity of 1200 fpm in duct systems up to 300 feet'.
- Galvanized steel housing with powder-coat finish
- Integrated Pressure Sensing Switch
- Wall-mount indicator panel
- Uses 4" duct
- 5 1/2 foot 120Vac power cord
- Mounting bracket and hardware included

#### SPECIFICATIONS

**FAN-** Inline fan with galvanized steel housing and backed powder-coat finish. Backward inclined blades of the motorized impeller allow lint to pass through the fan.

**PRESSURE SWITCH-** Fantech's patented pressure switch automatically activates the booster fan when dryer comes on. Includes 18" of pressure sensing tubing with mounting grommets.

**INDICATOR PANEL-** Wall-mount, low voltage indicator panel features an LED light that indicates to the homeowner that the fan is working properly. The indicator panel will alert homeowners of problems such as no power, blocked duct, locked motor rotor and low speed conditions. A 50 foot cable is included to connect the indicator panel to the booster fan.

Fan Model	RPM	Volts	Max Watts	Max Amps	Static Pressure in Inches W.G.									Max Ps	Duct Dia.
					0"	.125"	.25"	.375"	.5"	.75"	1.0"	1.25"	1.5"		
DBF4XLT	2800	115	83	0.73	195	181	167	153	141	120	101	81	55	2.05"	4"

Distributed by:

**Dimensions & Airflow** - All units feature 5 1/2 foot plug-in power cord.

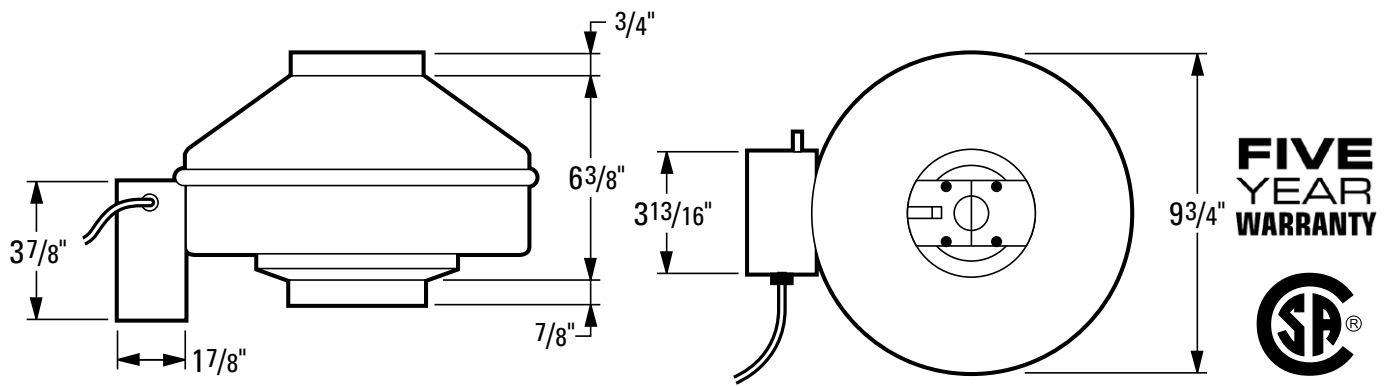

**Ventilation Performance**

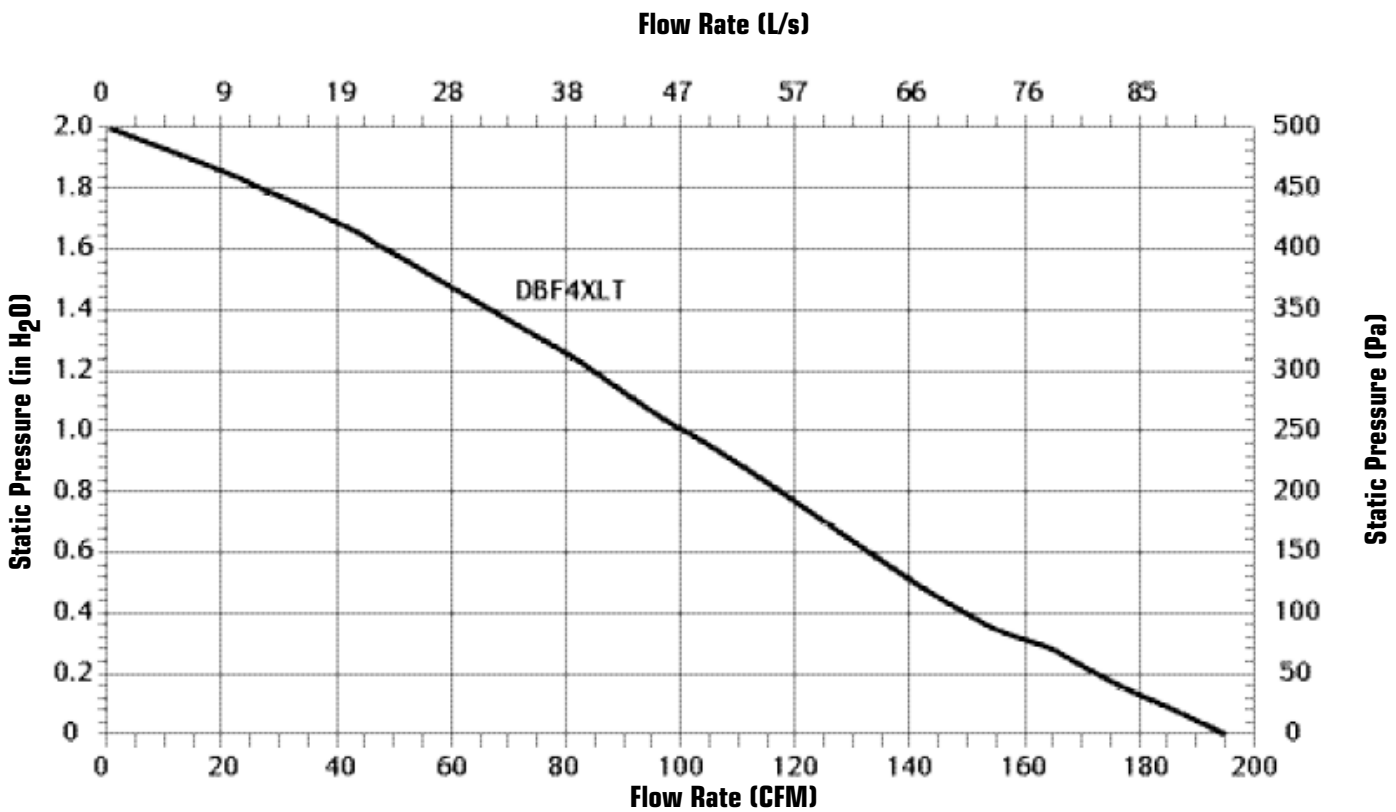

**Contacts**

Submitted by:	Date:
Qty:	Model #:
Comments:	
Project #:	
Location:	
Architect:	
Engineer:	
Contractor:	

Fantech reserves the right to modify, at any time and without notice, any or all of its products' features, designs, components and specifications to maintain their technological leadership position.



**United States**  
 10048 Industrial Blvd.  
 Lenexa, KS 66215  
 Phone: 800.747.1762; 913.752.6000  
 Fax: 800.487.9915; 913.752.6466

**Canada**  
 50 Kanalfakt Way,  
 Bouctouche, NB E4S 3M5  
 Phone: 800.565.3548; 506.743.9500  
 Fax: 877.747.8116; 506.743.9600

www.fantech.net; info@fantech.net

Item #: 802002  
 Rev Date: 081612