

200MD DUCTILE IRON GATE VALVE



- ❖ Ductile Iron Body ❖ Resilient Wedge ❖ Mechanical Joint Ends
 - ❖ Fusion Bonded Epoxy Coating ❖ Non Rising Stem ❖ Stainless Steel Stem
- 250 PSI CWP**

Applications: Potable Water, Water Distribution Service & Feed Lines,
Sewage Disposal, Irrigation, Turf, Golf Course

Product Spec Sheet



AWWA C515 MJ Ends Per ANSI/AWWA C111/A21.11

DIMENSIONS & WEIGHTS

Size	L	D2	D1	D	G	H	BOLT CIRCLE	QTY x DIA BOLT HOLE	APPROX. WT .LBS
2"	8.3	6.30	3.5	2.68	.59	9.85	4.88	2 x .75	28
3"	8.0	7.62	4.9	4.06	.59	12.46	6.19	4 x .75	44
4"	9.0	9.12	6.0	4.94	.60	13.35	7.50	4 x .88	69
6"	10.5	11.06	8.1	7.11	.63	16.57	9.50	6 x .88	119
8"	11.5	13.31	10.3	9.16	.66	20.75	11.75	8 x .88	203
10"	13.0	15.62	12.3	11.21	.70	24.33	14.00	8 x .88	278
12"	14.0	17.88	14.4	13.31	.73	27.56	16.25	8 x .88	421

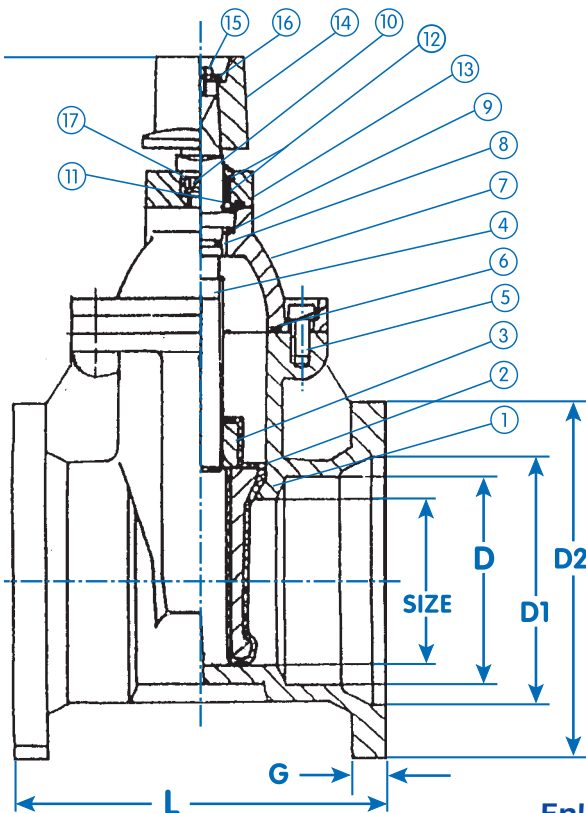

Enlarged Drawing On Page 2
(Click Here)

MATERIAL SPECIFICATIONS

NO.	Part	Material	ASTM Designation
1	Body	Ductile Iron	A536 65/45/12
2	Disc	D.I. Rubber Encapsulated	A536 65/45/12 /BUNA-N
3	Stem Nut	Bronze	B584 UNS C83600
4	Stem	Stainless Steel	AISI 410 UNS S41000
5	Bonnet Bolt	Stainless Steel	GR 304
6	Bonnet Gasket	BUNA-N	Commercial
7	Bonnet	Ductile Iron	A536 65/45/12
8	Split Ring	Brass	B16 UNS C36000
9	Thrust Washer	Stainless Steel	GR 304
10	Packing Box Bolt	Stainless Steel	GR 304
11	Packing Box Gasket	BUNA-N	Commercial
12	O-Rings	BUNA-N	Commercial
13	Packing Box	Ductile Iron	A536 65/45/12
14	Operating Nut	Ductile Iron	A536 65/45/12
15	Top Bolt	Stainless Steel	GR 304
16	Washer	Stainless Steel	AISI 410 UNS S41000
17	Wiper Ring	BUNA N	Commercial



Brewster, NY
TEL: 800-431-2082
FAX: 800-640-2252

Houston, TX
TEL: 800-935-5456
FAX: 800-683-4247

La Palma, CA
TEL: 866-532-8306
FAX: 866-532-8307

Americus, GA
TEL: 800-433-7526
FAX: 800-533-5134

e-mail: mail@matco-norca.com

www.matco-norca.com

200MD DUCTILE IRON GATE VALVE



Product Spec Sheet

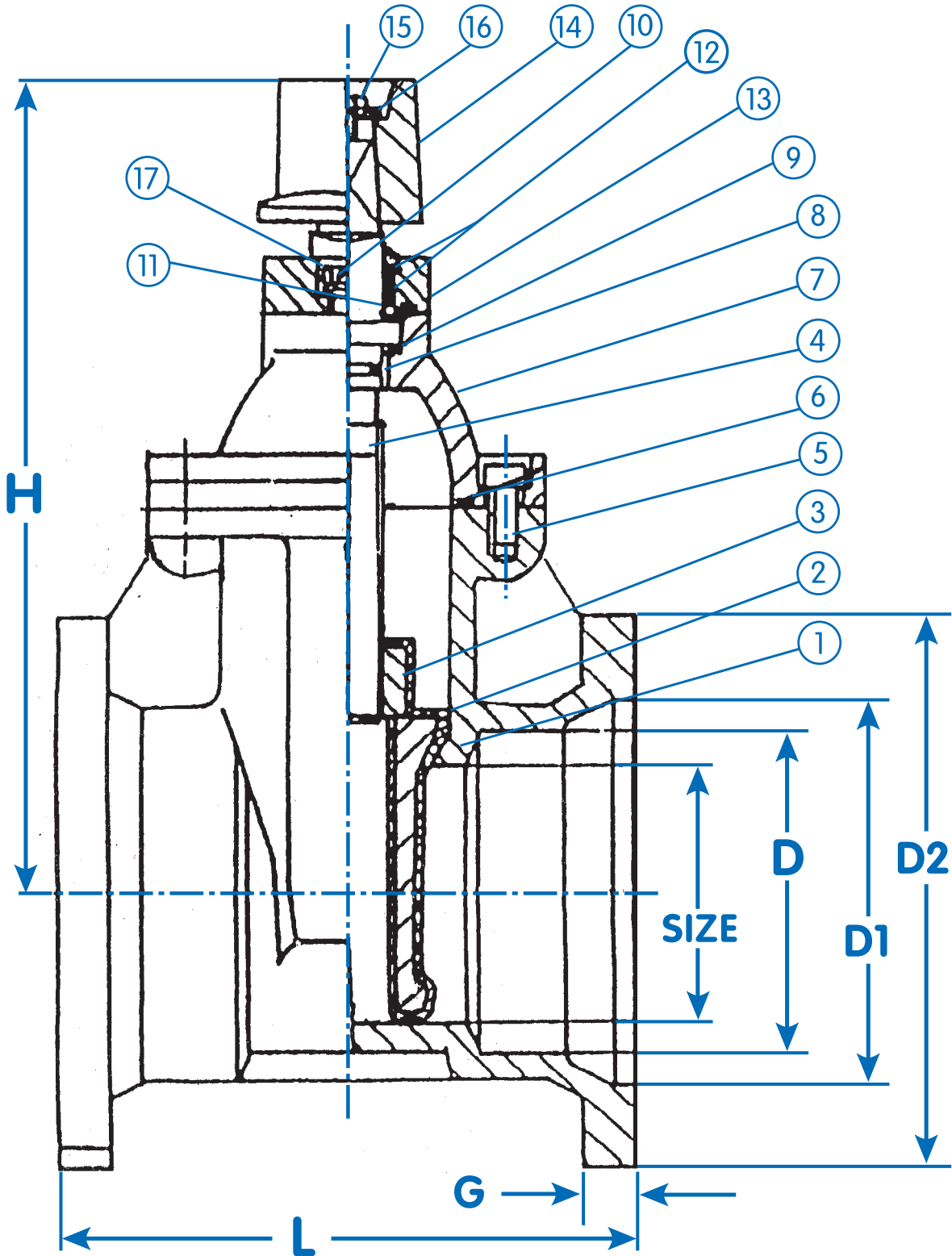

[Return To Page 1](#)
(Click Here)



Brewster, NY
TEL: 800-431-2082
FAX: 800-640-2252

Houston, TX
TEL: 800-935-5456
FAX: 800-683-4247

La Palma, CA
TEL: 866-532-8306
FAX: 866-532-8307

Americus, GA
TEL: 800-433-7526
FAX: 800-533-5134

e-mail: mail@matco-norca.com

www.matco-norca.com