

PF99509



ABS Check Valve

Product Features

- ABS Construction
- Full flow design
- Flapper opens 100%
- Flapper seat design reduces water hammer and debris buildup
- Inlet: 1-1/2" MPT
- Outlet: 1-1/4" barb or 1-1/2" slip

Specifications

- Max Temperature Rating: 140°F (60°C)
- Material: Black ABS
- Rubber Boot Installation: 10 feet of head/4.3 PSI
- Solvent Weld Installation: 58 feet of head/25 PSI



PF99509

Product Specifications

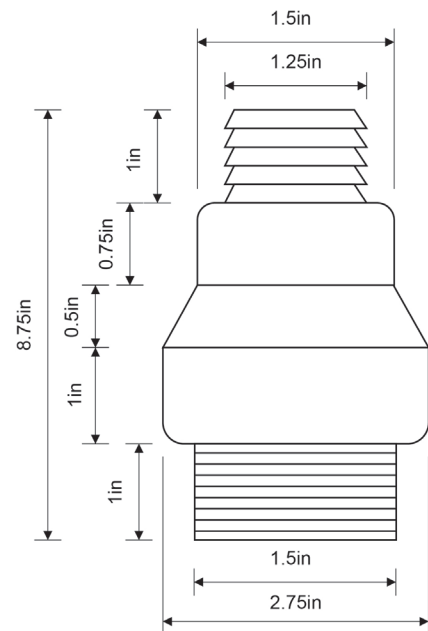

* All measurements are nominal. Please verify before actual installation.

Warranty and Codes

This PROFLO check valve carries a 1 year warranty when installed in residential applications.

In an effort to continually improve our products, we will make design changes from time to time. We reserve the right to ship newly designed product to fill any order unless it is agreed in writing to do otherwise.

