

40-000 SERIES FREEZE PROTECTION VALVE

Job Name:	Contractor:
Job Location:	P.O. Number:
Engineer:	Representative:
Tag:	Wholesale Distributor:

DESCRIPTION

The Apollo® 40-000 Series Freeze Protection Valve shall be installed to protect backflow preventers from freezing when installed in accordance with manufacturer's instructions. This valve will be American-manufactured with all internal parts replaceable.

FEATURES

- Corrosion resistant
- 1/4" MNPT inlet port
- Installs easily on all backflow preventers
- Discharge port accommodates 5/8" I.D. hose
- Compact, patented design (US # 6,374,849)
- MADE IN THE USA



ORDERING INFORMATION

4 0 - 0 0 0 - F P V X

OPTIONS

OPTIONS

- 1 - 1/8" NPT plug
- 2 - With Apollo® test cock (1/4" FNPT connection)
- R - Repair kit¹ for FPV1 and FPV2

Note:

¹Repair kit includes: Thermal element, spring, spring guide and two O-rings (all internal parts)

Example: 40-000-FPV1 = 1/4" male pipe thread inlet port w/ 1/8" NPT plug.

MATERIAL SPECIFICATIONS

Part Name	Material
Body	Bronze
Cap	Brass
Springs Guide	Brass
Spring	Stainless Steel
Cap O-Ring	Buna-N
Guide O-Ring	Buna-N
Thermal Element	Copper/Stainless Steel/EPDM

PERFORMANCE RATING

Operating Pressures 20 - 175 psi
 Temperature Range 33 °F – 180 °F
 Nominal Start to Open Temperature 35 °F

APPROVALS

IAPMO listed

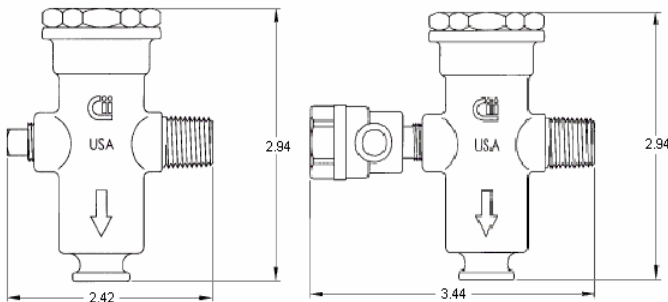

Model Number	40-000-FPV1	40-000-FPV2 w/ test cock
Net Weight (lbs.)	0.7	0.77

TYPICAL INSTALLATION

