

INSTALLATION INSTRUCTIONS

Start Capacitor & Relay Kit

NASA003SC, NASA004SC, NASA005SC, NASA006SC, NASA007SC, NASA008SC, NASA009SC

These instructions must be read and understood completely before attempting installation.

Safety Labeling and Signal Words

DANGER, WARNING, CAUTION, and NOTE

The signal words **DANGER**, **WARNING**, **CAUTION**, and **NOTE** are used to identify levels of hazard seriousness. The signal word **DANGER** is only used on product labels to signify an immediate hazard. The signal words **WARNING**, **CAUTION**, and **NOTE** will be used on product labels and throughout this manual and other manuals that may apply to the product.

DANGER – Immediate hazards which **will** result in severe personal injury or death.

WARNING – Hazards or unsafe practices which **could** result in severe personal injury or death.

CAUTION – Hazards or unsafe practices which **may** result in minor personal injury or product or property damage.

NOTE – Used to highlight suggestions which **will** result in enhanced installation, reliability, or operation.

Signal Words in Manuals

The signal word **WARNING** is used throughout this manual in the following manner:



The signal word **CAUTION** is used throughout this manual in the following manner:



Signal Words on Product Labeling

Signal words are used in combination with colors and/or pictures on product labels.

TABLE OF CONTENTS

Introduction	2
Description and Usage	2
Installation – Entry Models	3 – 4
Installation – Mainline Models	5 – 6
Wiring	7
Start-Up	7

WARNING

DEATH, PERSONAL INJURY, AND/OR PROPERTY DAMAGE HAZARD

Failure to carefully read and follow this warning could result in equipment malfunction, property damage, personal injury and/or death.

Installation or repairs made by unqualified persons could result in equipment malfunction, property damage, personal injury and/or death.

The information contained in this manual is intended for use by a qualified service technician familiar with safety procedures and equipped with the proper tools and test instruments.

Installation must conform with local building codes and with the National Electrical Code NFPA70 current edition or Canadian Electrical Code Part 1 CSA C.22.1.

INTRODUCTION

These instructions cover the installation of Start Capacitor & Relay Kits on split-system air conditioners and heat pumps.

The Start Capacitor & Relay Kit is designed to boost compressor starting torque.

WARNING

ELECTRICAL SHOCK HAZARD

Failure to turn off electric power could result in personal injury or death.

Before installing or servicing system, turn off main power to the system. There may be more than one disconnect switch, including accessory heater(s).

DESCRIPTION AND USAGE

The Start Capacitor & Relay kit causes the start capacitor to give the compressor a hard boost at each start-up. The relay takes the start capacitor out of the circuit after start-up.

Kit Number	START RELAY	START CAPACITOR	MICROFARAD / VOLTAGE
NASA003SC	HN61HB540	HC95DE088	88-108 / 330
NASA004SC	HN61HB540	HC95DE297	270-324 / 330
NASA005SC	HN61HB540	HC95DE045	176-216 / 330
NASA006SC	HN61HB551	HC95DE088	88-108 / 330
NASA007SC	HN61HB550	HC95DE088	88-108 / 330
NASA008SC	HN61HB540	HC95DE088	88-108 / 330
NASA009SC	HN61HB551	HC95DE297	270-324 / 330

Included in the kit are:

- Start Capacitor ----- 1
- Relay ----- 1
- Strap (capacitor)----- 1
- Screws ----- 3
- Black Wire ----- 1
- Blue Wire----- 1
- Brown Wire ----- 1
- Yellow Wire ----- 1
- Installation Instructions ----- 1

INSTALLATION – Entry Models

NOTE: Remove and discard PTC start thermistor if present.

Refer to Figure 1, Figure 2, and Figure 5.

1. Drill one 3.15mm hole for relay mounting in location shown in Figure 2.
2. Attach start relay to control box as shown in Figure 1 using one of the screws provided. Locate the tab on back of relay to the hole that was drilled in step 1.
3. Attach start capacitor to start capacitor strap (before assembly to control box). Start capacitor will face upward and the mounting tab will be to the left hand side. See Figure 1.
4. Attach start capacitor and strap assembly to control box as shown in Figure 1, using the hole shown in Figure 2. One screw is provided with kit to mount the capacitor strap.
5. Connect black wire to terminal 5 on start relay and piggyback to terminal 21 on contactor. See Figure 1.
6. Connect blue wire to terminal 2 on start relay and to H on run capacitor. See Figure 1.
7. Connect brown wire to terminal 1 on start relay and to either terminal on start capacitor. See Figure 1.
8. Connect yellow wire to open terminal on start capacitor and to C on run capacitor. See Figure 1.
9. Installation complete, continue to System Start-Up.

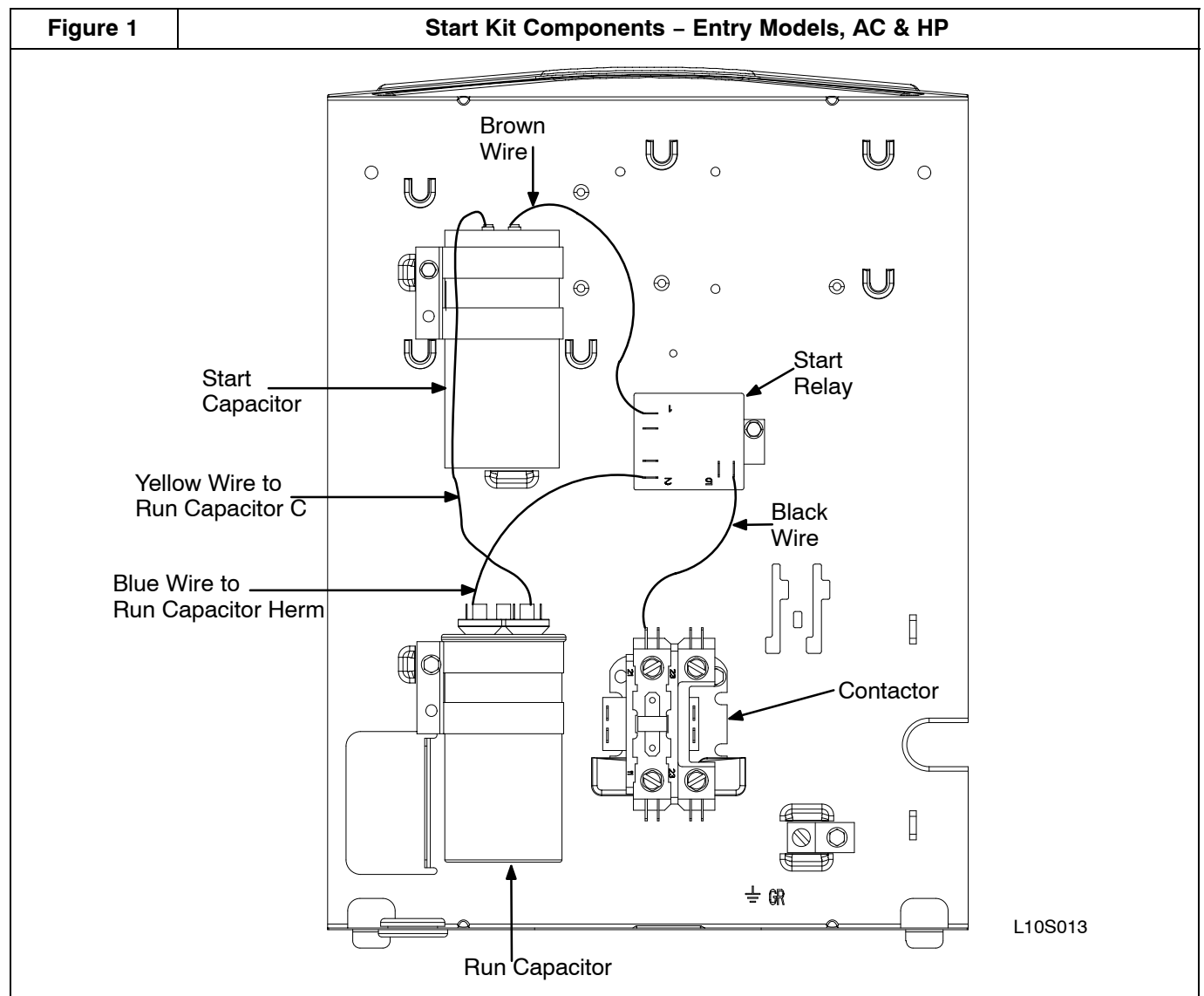
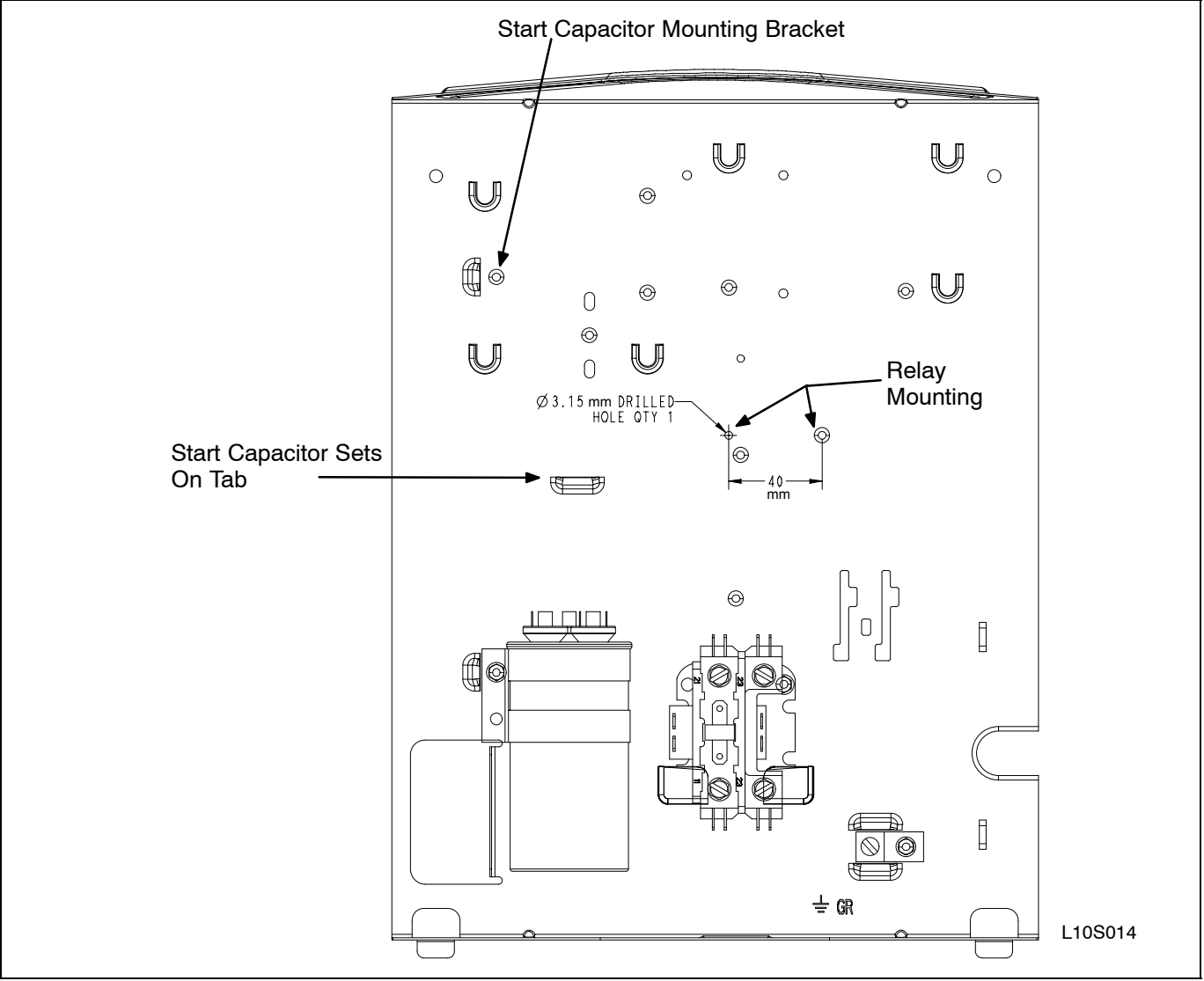

Figure 2 **Start Relay & Start Capacitor Mounting Locations – Entry Models, AC & HP**



INSTALLATION – Mainline Models

NOTE: Remove and discard PTC start thermistor if present.

Refer to Figure 3, Figure 4, and Figure 5.

1. Drill two 3.15mm holes for relay mounting in location shown in Figure 4.
2. Attach start relay to control box as shown in Figure 3 using one of the screws provided. Locate the tab on back of relay to the left hand hole that was drilled in step 1.
3. Attach start capacitor to start capacitor strap (before assembly to control box). Start capacitor will face upward and the mounting tab will be to the left hand side. See Figure 3.
4. Attach start capacitor and strap assembly to control box as shown in Figure 3, using the holes shown in Figure 4. One screw is provided with kit to mount the capacitor strap.
5. Connect straight terminal (flag on some kits) of black wire to terminal 5 on start relay and piggyback straight terminal to terminal 21 on contactor. See Figure 3.
6. Connect straight terminal (flag on some kits) of blue wire to terminal 2 on start relay and straight terminal to H on run capacitor. See Figure 3.
7. Connect straight terminal (flag on some kits) of brown wire to terminal 1 on start relay and straight terminal to start capacitor. See Figure 3.
8. Connect yellow wire to start capacitor and to C on run capacitor. See Figure 3.
9. Installation complete, continue to System Start-Up.

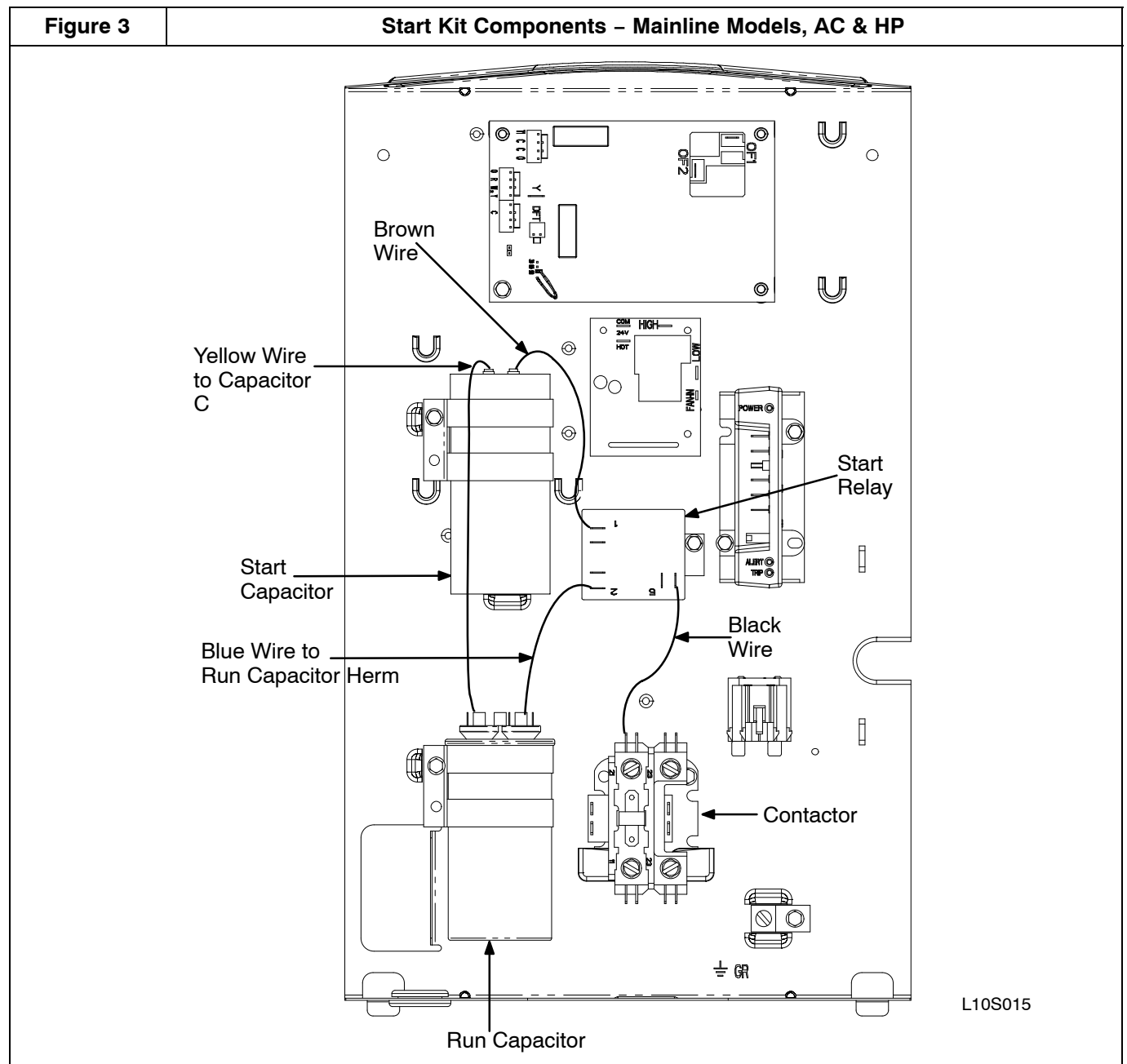

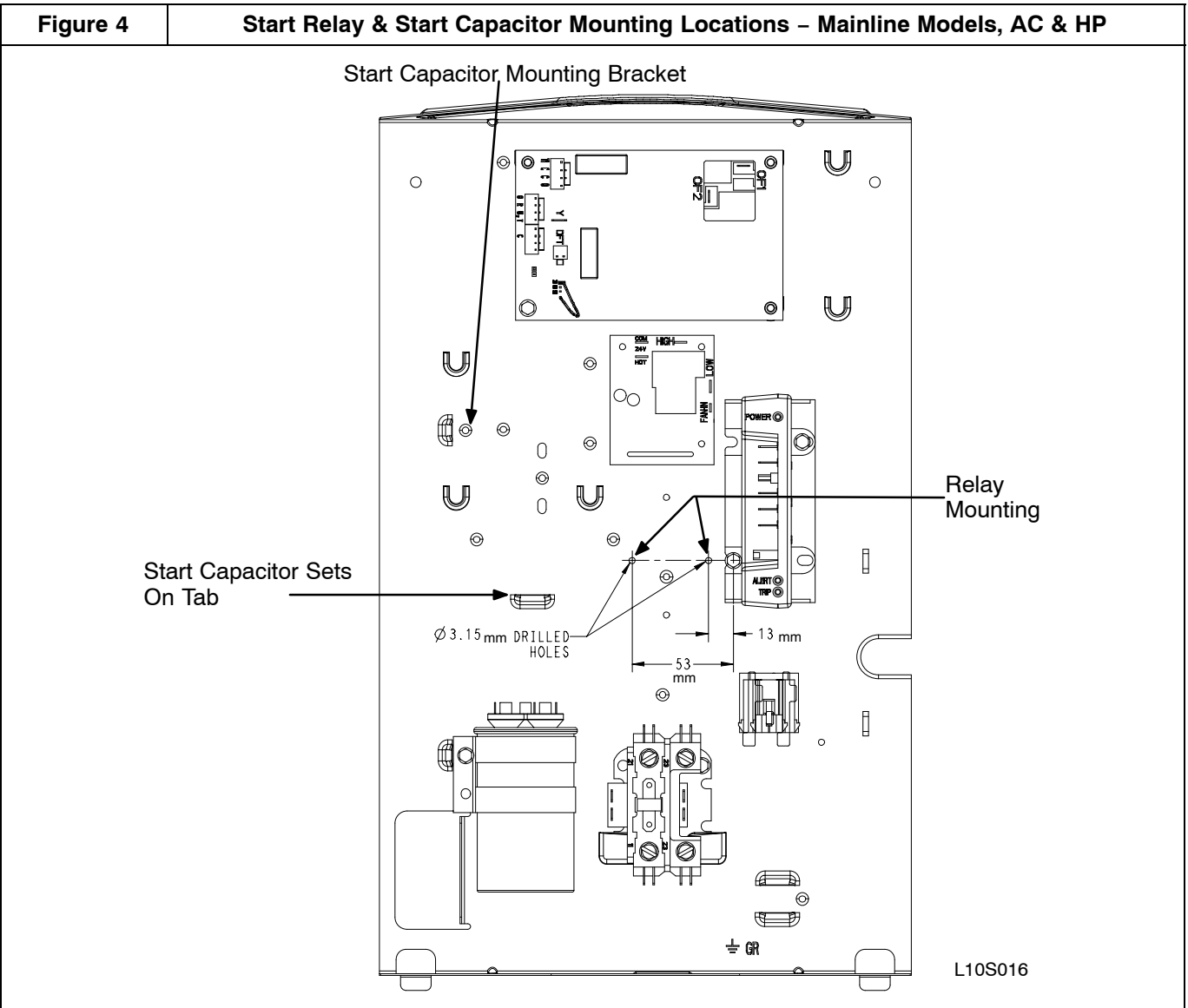

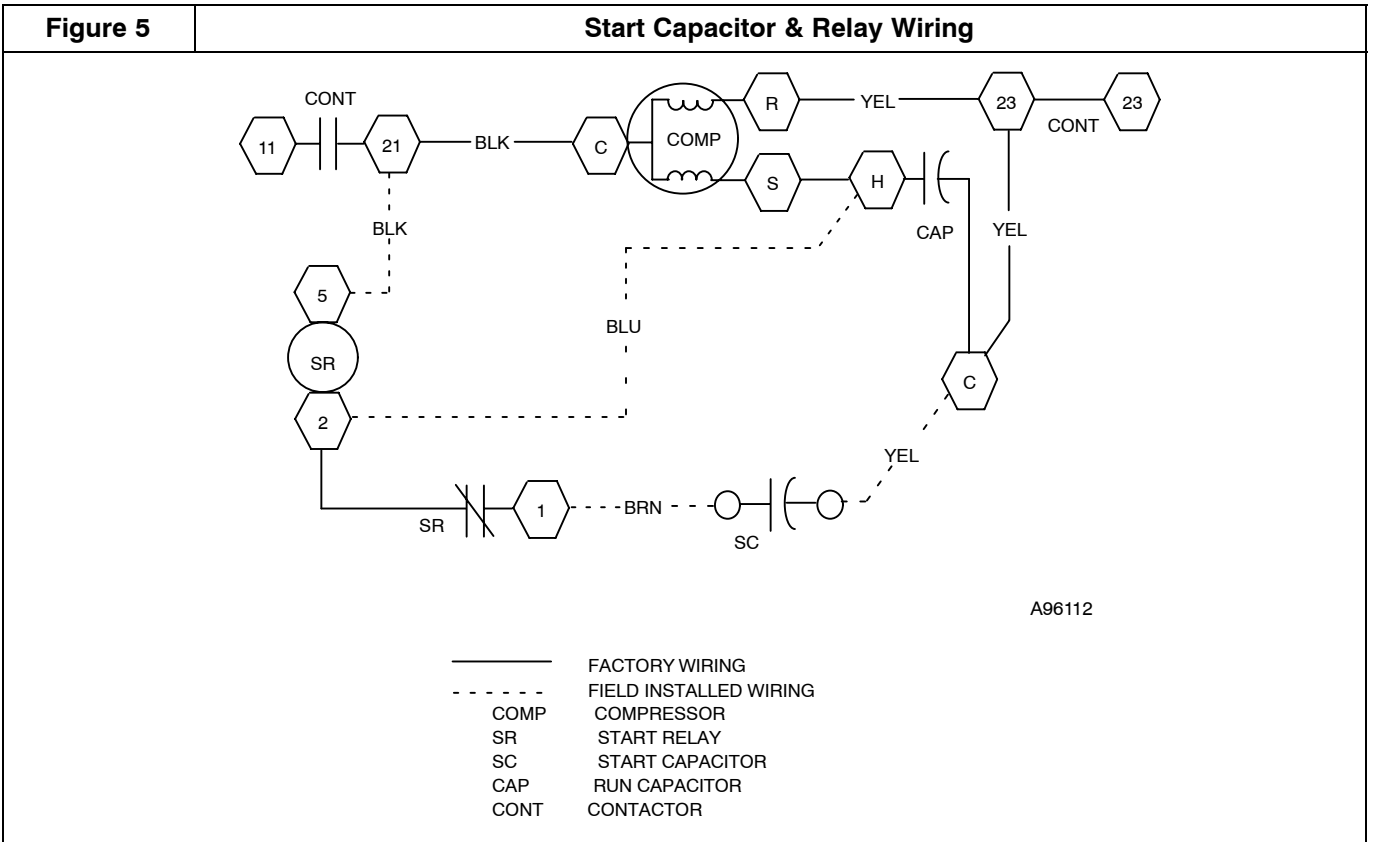

SYSTEM START-UP

Check all electrical connections for proper position. Check system pressures for equalization. Restore power to unit and start compressor. If the compressor fails to start, check unit wiring. Power supply must be within operating voltage range indicated on unit rating plate.