

# 1299CGC

APPROX. WEIGHT WITH FRAME = 39.90 LBS

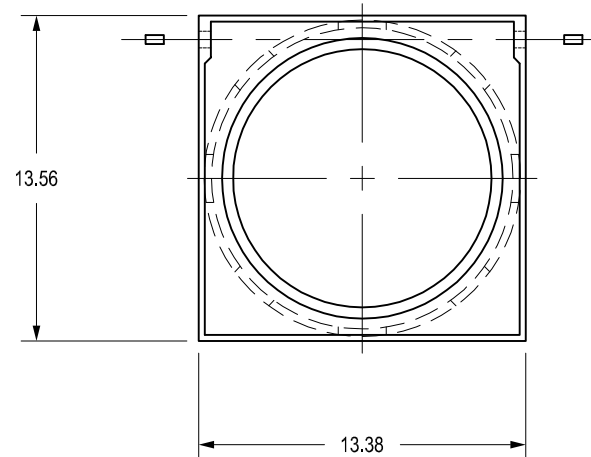
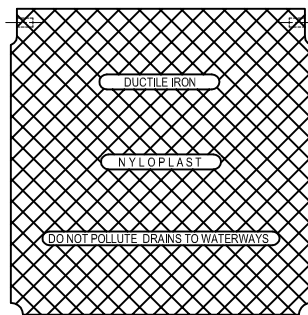
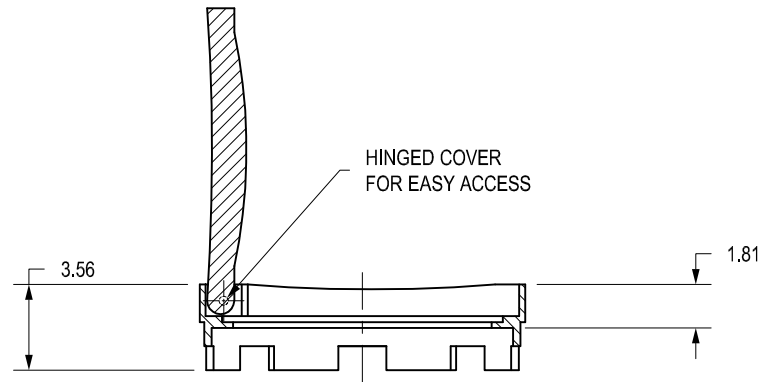

DIMENSIONS ARE FOR REFERENCE ONLY  
 ACTUAL DIMENSIONS MAY VARY  
 DIMENSIONS ARE IN INCHES  
 GRATE MEETS H-20 LOAD RATING  
 QUALITY: MATERIALS SHALL CONFORM TO ASTM A536 GRADE 70-50-05  
 PAINT: CASTINGS ARE FURNISHED WITH A BLACK PAINT  
 LOCKING DEVICE AVAILABLE UPON REQUEST SEE DRAWING NO.  
 7001-110-033

THIS PRINT DISCLOSES SUBJECT MATTER IN WHICH NYLOPLAST HAS PROPRIETARY RIGHTS. THE RECEIPT OR POSSESSION OF THIS PRINT DOES NOT CONFER, TRANSFER, OR LICENSE THE USE OF THE DESIGN OR TECHNICAL INFORMATION SHOWN HEREIN REPRODUCTION OF THIS PRINT OR ANY INFORMATION CONTAINED HEREIN, OR MANUFACTURE OF ANY ARTICLE HEREFROM, FOR THE DISCLOSURE TO OTHERS IS FORBIDDEN, EXCEPT BY SPECIFIC WRITTEN PERMISSION FROM NYLOPLAST.  
 ©2010 NYLOPLAST

DRAWN BY	EBC	MATERIAL
DATE	3-3-06	DUCTILE IRON
REVISED BY	EBC	PROJECT NO./NAME
DATE	3-16-10	
DWG SIZE	A	SCALE 1:8 SHEET 1 OF 1

 <b>Nyloplast</b>	3130 VERONA AVE BUFORD, GA 30518 PHN (770) 932-2443 FAX (770) 932-2490 www.nyloplast-us.com
	TITLE
12 IN SOLID COVER ASSEMBLY	
DWG NO.	7001-110-204 REV C