

Series DS-1 Stainless Steel Dry-Type Sprinklers 5.6K Pendent, HSW, and Extended Coverage HSW Standard and Quick Response

General Description

TYCO Series DS-1 Dry-Type Sprinklers, 5.6K Stainless Steel Pendent, Horizontal Sidewall, Standard (5 mm Bulb) and Quick (3 mm Bulb) Response, Extended Coverage, are the first stainless steel dry-type sprinklers to be listed by UL and C-UL. With a K-Factor of 5.6, these corrosion-resistant automatic sprinklers can be used in wet-pipe, dry-pipe, or preaction systems.

These pendent and horizontal sidewall sprinklers are available in a variety of configurations to suit coverage type and thermal sensitivity. Refer to the Model/Sprinkler Identification Numbers (SINs) section for details.

Series DS-1 Stainless Steel Dry-Type Sprinklers are typically used:

- where corrosive atmospheres exist; for example, salt-water areas, parking garages, chemical storage areas, mechanical rooms, industrial manufacturing sites, and software chip washing facilities.
- on dry-pipe systems exposed to freezing temperatures; for example, sprinkler drops from unheated portions of buildings.
- with pipe connections exposed to freezing temperatures; for example, sprinkler drops from wet-pipe systems into freezers or horizontal piping extensions to protect unheated areas.

IMPORTANT

Always refer to Technical Data Sheet TFP700 for the "INSTALLER WARNING" that provides cautions with respect to handling and installation of sprinkler systems and components. Improper handling and installation can permanently damage a sprinkler system or its components and cause the sprinkler to fail to operate in a fire situation or cause it to operate prematurely.

- in systems that are seasonably drained to avoid freezing; for example, vacation areas.

The stainless-steel construction of these sprinklers extends the life of a sprinkler beyond that of traditional copper alloy sprinklers exposed to corrosive atmospheres. Although corrosion-resistant sprinklers have passed the standard corrosion tests of the applicable approval agencies, the testing is not representative of all possible corrosive atmospheres.

Consequently, it is necessary that the end user be consulted with respect to the suitability of this alternate material of construction for any given corrosive environment. As a minimum, consider the following criteria:

- ambient temperature
- concentration of chemicals
- humidity
- gas/chemical velocity
- corrosive nature of the chemical to which the sprinklers are exposed

Stainless Steel Pendent Dry-Type Sprinklers. The pendent sprinklers are provided with stainless steel es-cutcheons that allow vertical adjustment during installation. This adjustment provides a measure of flexibility in determining the length of fixed piping to cut for sprinkler drops.

Stainless Steel Sidewall Dry-Type Sprinklers. The horizontal sidewall sprinklers are designed for installation along a wall or side of a soffit and just beneath a smooth ceiling. Sidewall sprinklers are commonly used instead of pendent sprinklers due to aesthetics or building construction considerations where piping along the ceiling is not desirable.

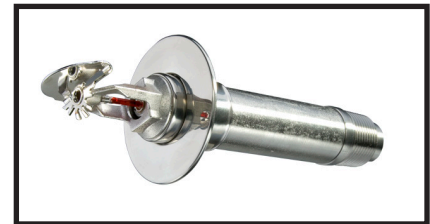

NOTICE

The Series DS-1 Stainless Steel Dry-Type Sprinklers described herein must be installed and maintained in compliance with this document, as well as with the applicable standards of the National Fire Protection Association, in addition to the standards of any Authorities Having Jurisdiction. Failure to do so may impair the performance of these devices.

Owners are responsible for maintaining their fire protection system and devices in proper operating condition. The installing contractor or sprinkler manufacturer should be contacted with any questions.

The Series DS-1 Stainless Steel Dry-Type Sprinklers must only be installed in fittings that meet the requirements of the Design Criteria section.

Temperature Rating	Bulb Color Code	Standard Coverage				Extended Coverage Horizontal Sidewall
		Pendent		Horizontal Sidewall		TY3339 (3 mm Bulb) ^(c) w/ Standard Escutcheon (Figure 17)
		TY3230 (3 mm Bulb) w/ Standard Escutcheon (Figure 10) w/ Recessed Escutcheon ^(a) (Figure 11) w/ Deep Escutcheon (Figure 12) w/o Escutcheon (Figure 13)	TY3250 (5 mm Bulb) w/ Standard [†] Escutcheon (Figure 10) w/ Recessed Escutcheon ^(a) (Figure 11) w/ Deep [†] Escutcheon (Figure 12) w/o [†] Escutcheon (Figure 13)	TY3337 (3 mm Bulb) ^(b) w/ Standard Escutcheon (Figure 14) w/ Deep Escutcheon (Figure 15) w/o Escutcheon (Figure 16)	TY3357 (5 mm Bulb) ^(b) w/ Standard Escutcheon (Figure 14) w/ Deep Escutcheon (Figure 15) w/o Escutcheon (Figure 16)	
135°F (57°C)	Orange	1, 2	1, 2	1*, 2*	1*, 2*	1**, 2**
155°F (68°C)	Red	1, 2	1, 2, 3 [†]	1*, 2*	1*, 2*	1**, 2**
175°F (79°C)	Yellow	1, 2	1, 2	1*, 2*	1*, 2*	-
200°F (93°C)	Green	1, 2	1, 2, 3 [†]	1*, 2*	1*, 2*	-
286°F (141°C)	Blue	1, 2	1, 2, 3 [†]	1*, 2*	1*, 2*	-
360°F (182°C)	Mauve	-	1, 2	-	1*, 2*	-

Notes:

- Listed by Underwriters Laboratories, Inc. (UL). Stainless steel sprinklers noted to be UL Listed are listed as Corrosion Resistant Sprinklers. Maximum order lengths are described in Figures 10 - 17.
 - Listed by Underwriters Laboratories for use in Canada (C-UL). Stainless steel sprinklers noted to be C-UL Listed are listed as Corrosion Resistant Sprinklers. Maximum order lengths are described in Figures 10 - 17.
 - Loss Prevention Certification Board approval and CE conformity apply to these temperature ratings only.
- † LPCB approval and CE conformity apply to only these configurations for TY3250 with only these indicated temperatures.
- * Light and Ordinary Hazard Occupancies Only
- ** Light Hazard Occupancies Only
- Not Applicable
- (a) This configuration is applicable only up to 200°F (93°C).
- (b) To meet the deflector-to-ceiling distance of 4 to 12 inches (100 to 300 mm) for the standard coverage horizontal sidewall, the centerline of the sprinkler waterway must be 4-5/16 to 12-5/16 inches below the ceiling.
- (c) To meet the deflector-to-ceiling distance of 4 to 12 inches (100 to 300 mm) for the extended coverage horizontal sidewall, the centerline of the sprinkler waterway must be 4-7/16 to 12-7/16 inches below the ceiling.

TABLE A
SERIES DS-1 STAINLESS STEEL PENDENT AND HORIZONTAL SIDEWALL DRY-TYPE SPRINKLERS
STANDARD AND EXTENDED COVERAGE
— LABORATORY LISTINGS AND APPROVALS —

APPLICATION ⁽¹⁾	Coverage ⁽²⁾ W x L Ft. x Ft. (m x m)	Minimum Flow GPM (LPM)	Minimum Pressure psi (bar)	Temperature Rating	Top of Deflector-to- Ceiling Distance ⁽²⁾
TY3339 (3 mm Bulb) For Quick Response, Light Hazard Extended Coverage Per NFPA 13	16 x 16 (4,9 x 4,9)	26 (98)	21.6 (1,49)	135°F (57°C) and 155°F (68°C)	4 inches (100 mm) to 12 inches (300 mm)
	16 x 18 (4,9 x 5,5)	29 (110)	26.8 (1,85)		
	16 x 20 (4,9 x 6,1)	32 (121)	32.7 (2,25)		
	18 x 16 (5,5 x 4,9)	29 (110)	26.8 (1,85)		

Notes:

1. These sprinklers are Listed by UL and C-UL. Stainless steel sprinklers noted to be UL and C-UL Listed are listed as Corrosion Resistant Sprinklers.
2. The minimum allowable spacing between sprinklers to prevent cold soldering is 14 feet (4,3 m).

TABLE B
SERIES DS-1 STAINLESS STEEL EXTENDED COVERAGE HORIZONTAL SIDEWALL DRY-TYPE SPRINKLERS
– UL AND C-UL INSTALLATION CRITERIA –

Model/Sprinkler Identification Numbers (SINs)

Standard Coverage Pendent

TY3230 – 3 mm Bulb
TY3250 – 5 mm Bulb

Standard Coverage Horizontal Sidewall

TY3337 – 3 mm Bulb
TY3357 – 5 mm Bulb

Extended Coverage Horizontal Sidewall

TY3339 – 3 mm Bulb

Technical Data

Approvals

- UL and C-UL Listed
- LPCB Approved: Ref. No. 094a/12
- CE Certified: EN 12259-1

Refer to Tables A and B for details.

Maximum Working Pressure

175 psi (12,1 bar)

Inlet Thread Connections

- 1-Inch NPT
- ISO 7-R1

Discharge Coefficient

$K = 5.6 \text{ GPM/psi}^{1/2}$
(80,6 LPM/bar^{1/2})

Temperature Ratings

Refer to Tables A and B.

Finishes

Sprinkler: Stainless Steel
Escutcheon: Stainless Steel

Physical Characteristics

With the exceptions of the Bulb, the Insert, the Deflector, and the Sealing Assembly, all components of the Series DS-1 Stainless Steel Dry-Type Sprinkler are constructed with Type 316 Stainless Steel.

- The Bulb is Glass.
- The Insert is 300 Series Stainless Steel.
- The Deflector is Type 316L Stainless Steel.

The Sealing Assembly consists of a Disc Spring that is sealed on both its inside and outside faces with a TEF-LON gasket. The Disc Spring is 1/2 Hard Beryllium Nickel.

Refer to Figures 1 through 3 for component assemblies.

Operation

When the TYCO Series DS-1 Stainless Steel Dry-Type Sprinkler is in service, water is prevented from entering the assembly by the Plug with Sealing Assembly in the Inlet of the Sprinkler. Refer to Figures 1 through 3.

The glass Bulb contains a fluid that expands when exposed to heat. When the rated temperature is reached, the fluid expands sufficiently to shatter the glass Bulb then release the Bulb Seat.

The compressed Spring is then able to expand and push the Water Tube as well as the Guide Tube outward. This outward action simultaneously pulls inward on the Yoke, withdrawing the Plug with Sealing Assembly from the Inlet and allowing the sprinkler to activate and flow water effectively.

Design Criteria

The TYCO Series DS-1 Stainless Steel Dry-Type Standard Coverage Sprinklers are intended for use in fire sprinkler systems designed in accordance with the standard installation rules recognized by the applicable Listing or Approval agency; for example, UL Listing is based on NFPA 13 requirements.

For more information on LPCB Approval, contact Tyco Fire Protection Products at the following office:

Kopersteden 1
7547 TJ Enschede
The Netherlands
Tel: +31-(0)53-428-4444
Fax: +31-(0)53-428-3377

The Series DS-1 Stainless Steel Extended Coverage Sprinklers are intended for use in fire sprinkler systems designed in accordance with extended coverage installation guidelines provided by NFPA 13 and the installation criteria provided by Table B.

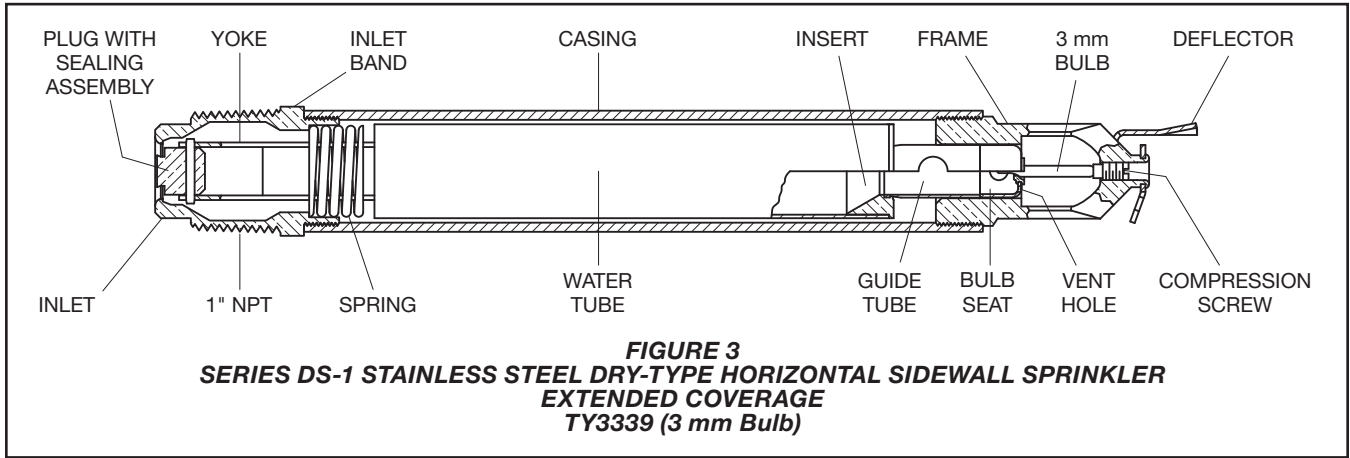
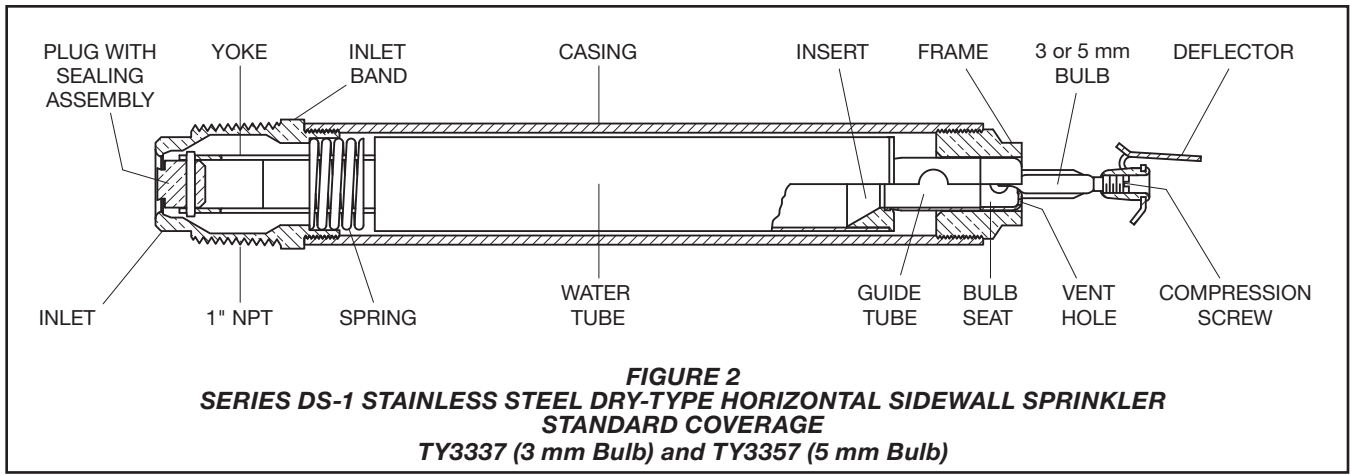
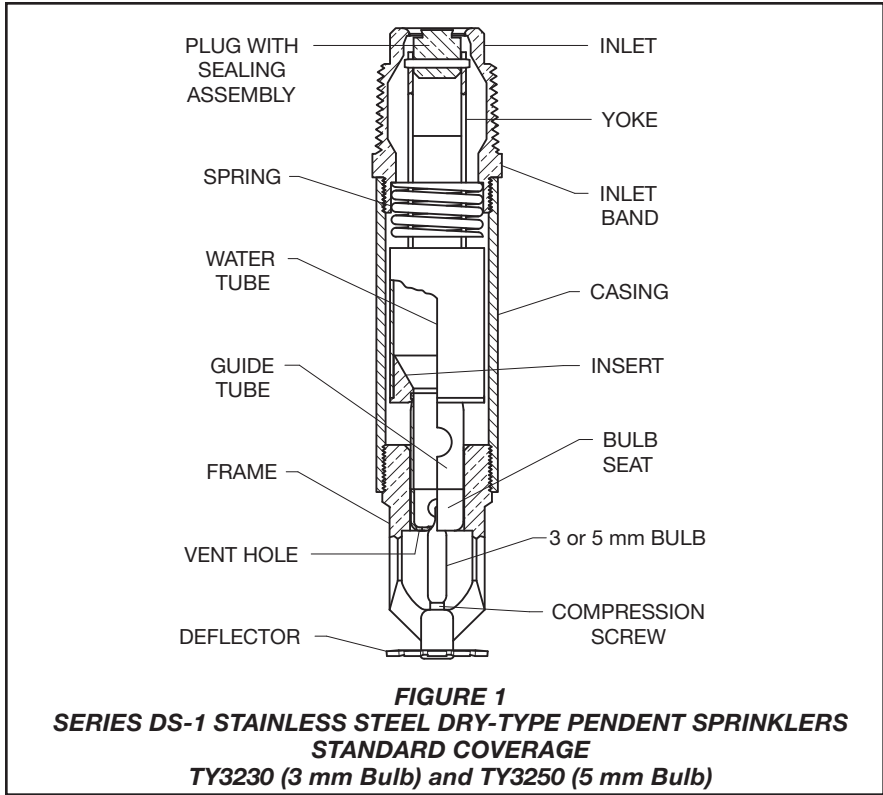

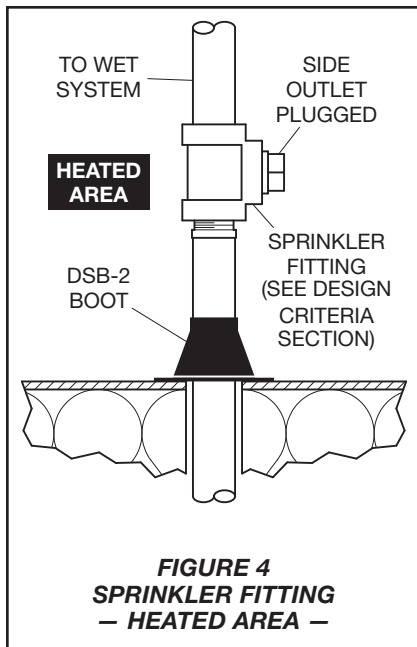

FIGURE 4
SPRINKLER FITTING
— HEATED AREA —

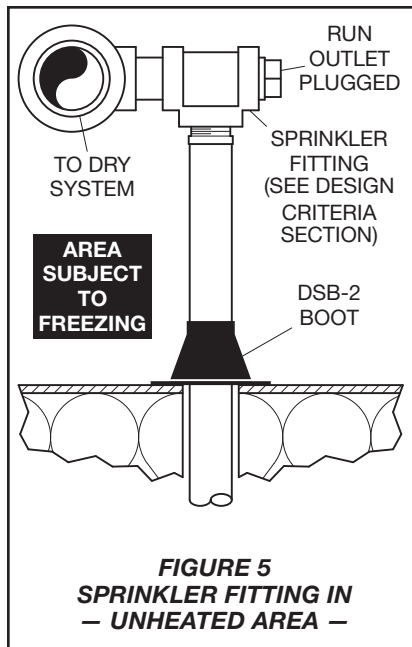

FIGURE 5
SPRINKLER FITTING IN
— UNHEATED AREA —

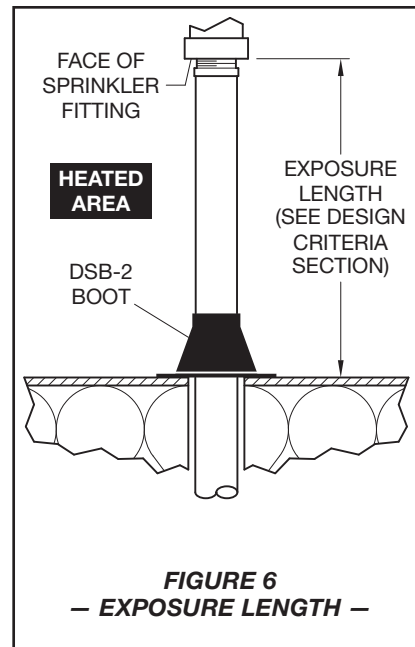

FIGURE 6
— EXPOSURE LENGTH —

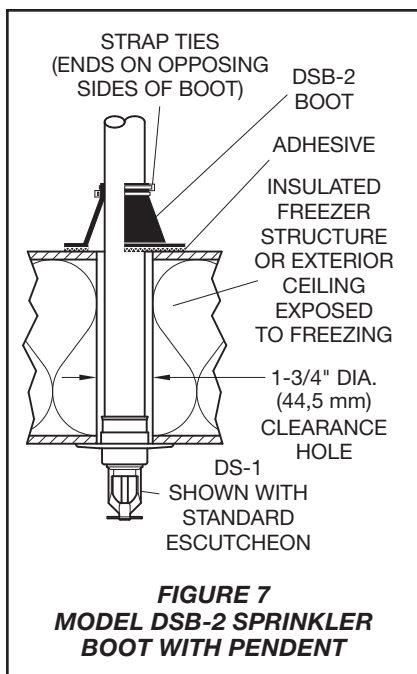

FIGURE 7
MODEL DSB-2 SPRINKLER
BOOT WITH PENDENT

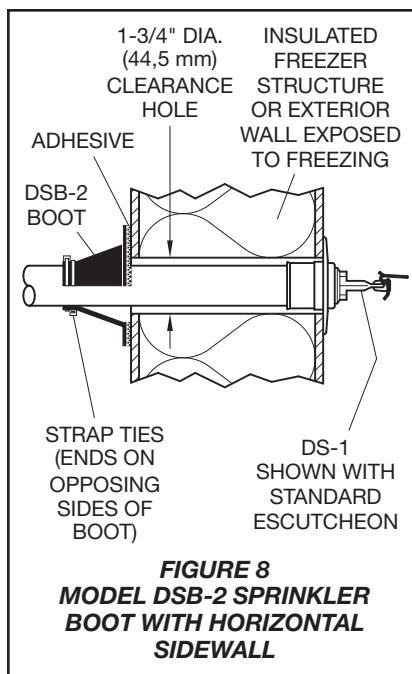

FIGURE 8
MODEL DSB-2 SPRINKLER
BOOT WITH HORIZONTAL
SIDEWALL

Sprinkler Fittings

Install the 1-Inch NPT Series DS-1 Stainless Steel Dry-Type Sprinkler in the 1-Inch NPT outlet or run of one of the following fittings:

- malleable or ductile iron threaded tee fittings that meet the dimensional requirements of ANSI B16.3 (Class 150).
- cast iron threaded tee fittings that meet the dimensional requirements of ANSI B16.4 (Class 125).

- cast bronze threaded tee fittings that meet the dimensional requirements of ANSI B16.15 (Class 125).
- stainless steel threaded tee fittings that meet the dimensional requirements of MSS SP-114.

Do not install the Series DS-1 Stainless Steel Dry-Type Sprinklers into elbow fittings. The inlet of the sprinkler can contact the interior of the elbow, potentially damaging the Inlet seal.

The unused outlet of the threaded tee is plugged as shown in Figures 4 and 5.

You can also install the Series DS-1 Sprinklers in the 1-Inch NPT outlet of a GRINNELL Figure 730 Mechanical Tee. However, the use of the Figure 730 Tee for this arrangement is limited to wet-pipe systems.

The configuration shown in Figure 4 is only applicable for wet-pipe systems where the sprinkler fitting and water-filled pipe above the sprinkler fitting are not subject to freezing and where the length of the Stainless Steel Dry-Type Sprinkler has the minimum exposure length depicted in Figure 6. Refer to the Exposure Length section.

For wet-pipe system installations of the 1-Inch NPT Series DS-1 Stainless Steel Dry-Type Sprinklers connected to CPVC piping, use only the following TYCO CPVC fittings:

- 1" x 1" NPT Female Adapter (P/N 80145)
- 1" x 1" x 1" NPT Sprinkler Head Adapter Tee (P/N 80249)

For dry-pipe system installations, use only the side outlet of maximum 2-1/2 inch reducing tee when locating the Series DS-1 Stainless Steel Dry-Type Sprinklers directly below the branch line. Otherwise, use the configuration shown in Figure 5 to assure complete water drainage from above the Series DS-1 Stainless Steel Dry-Type Sprinklers and the branch line. Failure to do so may result in pipe freezing and water damage.

Ambient Temperature Exposed to Discharge End of Sprinkler	Temperatures for Heated Area ^(a)		
	40°F (4°C)	50°F (10°C)	60°F (16°C)
	Minimum Exposed Barrel Length, Inches (mm) ^(b)		
40°F (4°C)	0	0	0
30°F (-1°C)	0	0	0
20°F (-7°C)	4 (100)	0	0
10°F (-12°C)	8 (200)	1 (25)	0
0°F (-18°C)	12 (305)	3 (75)	0
-10°F (-23°C)	14 (355)	4 (100)	1 (25)
-20°F (-29°C)	14 (355)	6 (150)	3 (75)
-30°F (-34°C)	16 (405)	8 (200)	4 (100)
-40°F (-40°C)	18 (455)	8 (200)	4 (100)
-50°F (-46°C)	20 (510)	10 (255)	6 (150)
-60°F (-51°C)	20 (510)	10 (255)	6 (150)

Notes:

- (a) For protected area temperatures that occur between values listed above, use the next cooler temperature.
- (b) These lengths are inclusive of wind velocities up to 30 mph (18,6 kph).

TABLE C
MINIMUM RECOMMENDED LENGTHS OF EXPOSED SPRINKLER BARRELS
IN WET-PIPE SYSTEMS

NOTICE

Do not install the Series DS-1 Stainless Steel Dry-Type Sprinklers into any other type fitting without first consulting the Technical Services Department. Failure to use the appropriate fitting can result in one of the following:

- Failure of the sprinkler to operate properly due to formation of ice over the Inlet Plug or binding of the Inlet Plug.
- Insufficient engagement of the Inlet pipe threads with consequent leakage.

Drainage

In accordance with the minimum requirements of the National Fire Protection Association for dry-pipe sprinkler systems, pitch branch, cross, and feed main piping connected to Stainless Steel Dry-Type Sprinklers and subject to freezing temperatures to allow proper drainage.

Exposure Length

When using Stainless Steel Dry-Type Sprinklers in wet-pipe sprinkler systems protecting areas subject to freezing temperatures, use Table C to determine a sprinkler's appropriate exposed barrel length to prevent water from freezing in the connecting pipes due to conduction. The exposed barrel length measurement must be taken from the face of the sprinkler fitting to the surface of the structure or insulation that is exposed to the heated area. Refer to Figure 6 for an example.

Clearance Space

Section 8.4.9.2 of 2010 edition of NFPA 13 requires a sealed clearance space around the sprinkler barrel of dry sprinklers that are connected to wet-pipe sprinkler systems protecting insulated freezer structures. The use of the Model DSB-2 Dry Sprinkler Boot, described in technical data sheet TFP591 and illustrated in Figures 7 and 8, meets this NFPA 13 requirement.

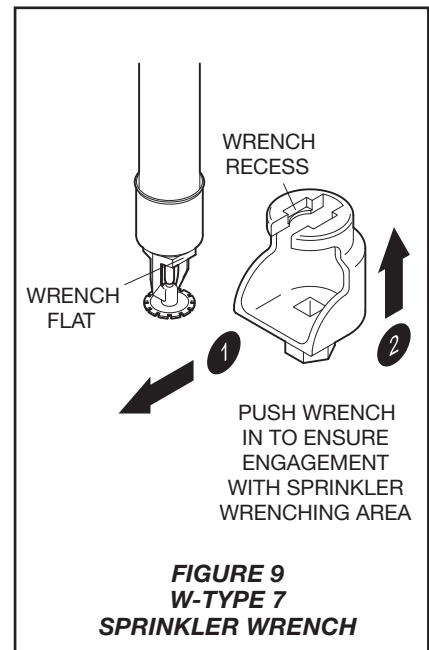

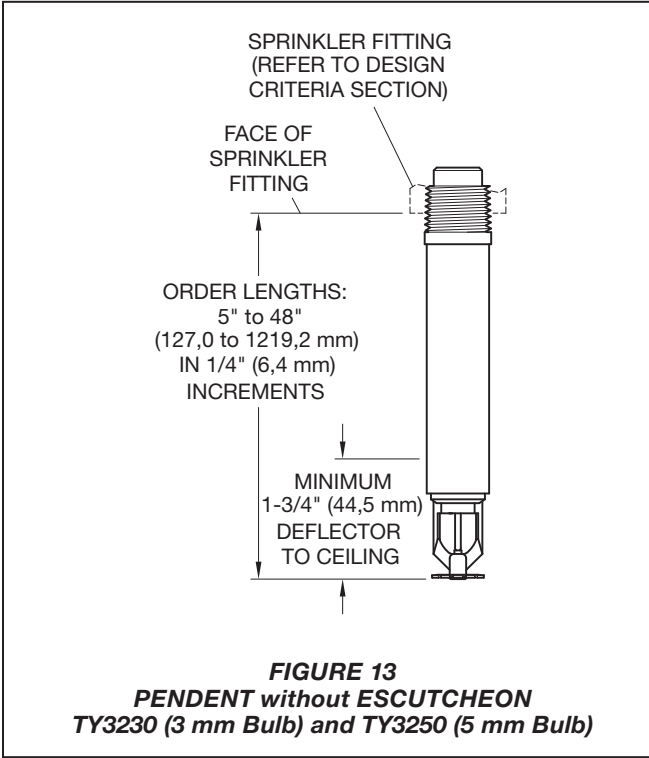
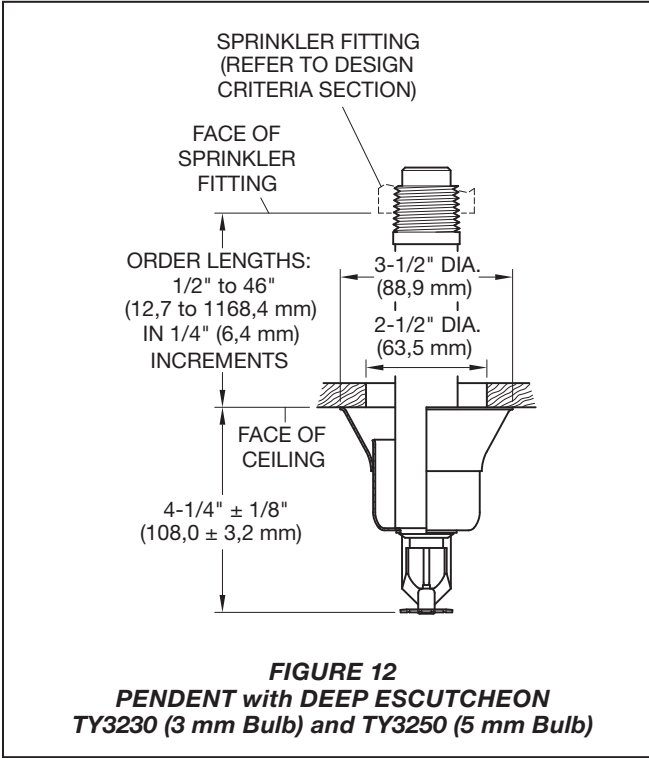
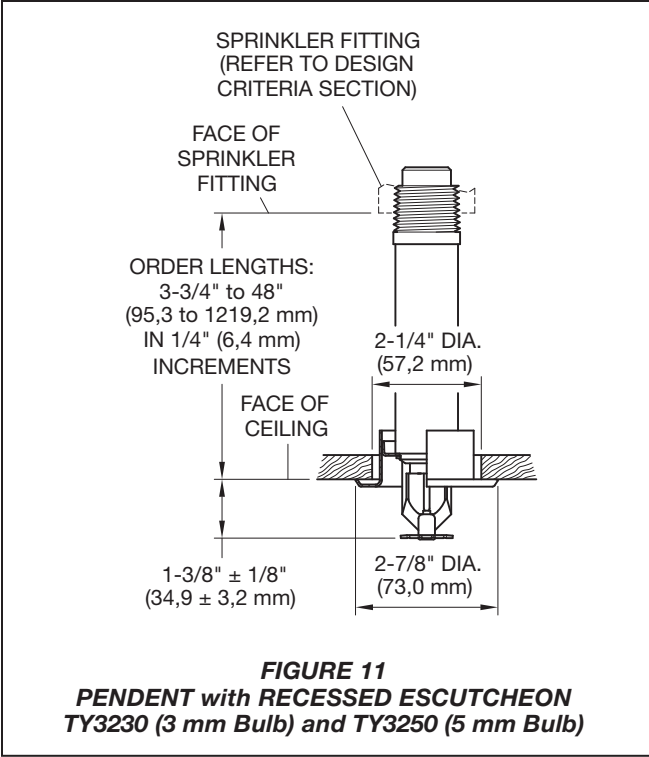
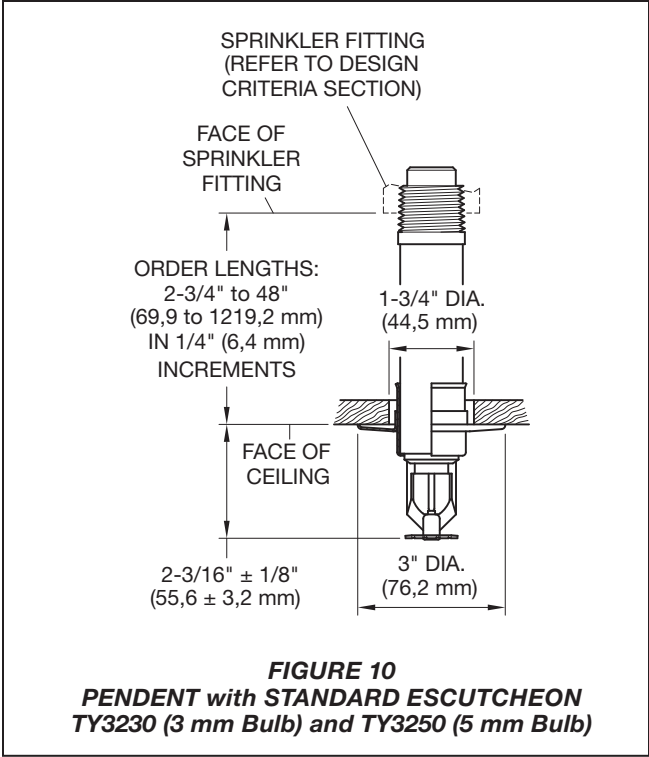

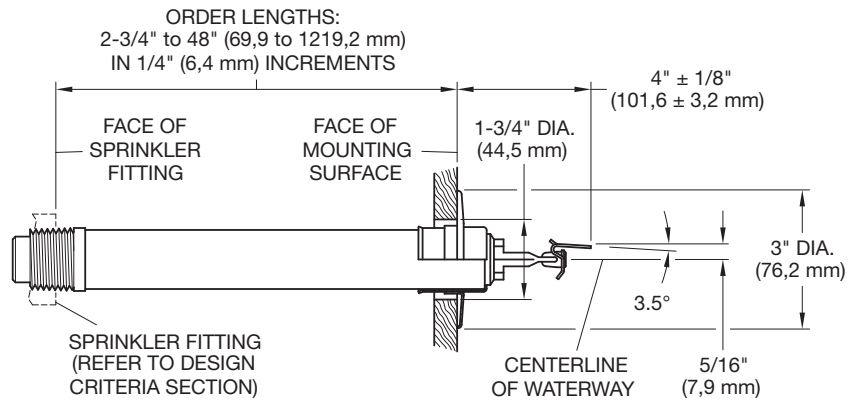

FIGURE 14
STANDARD COVERAGE HORIZONTAL SIDEWALL with STANDARD ESCUTCHEON
TY3337 (3 mm Bulb) and TY3357 (5 mm Bulb)

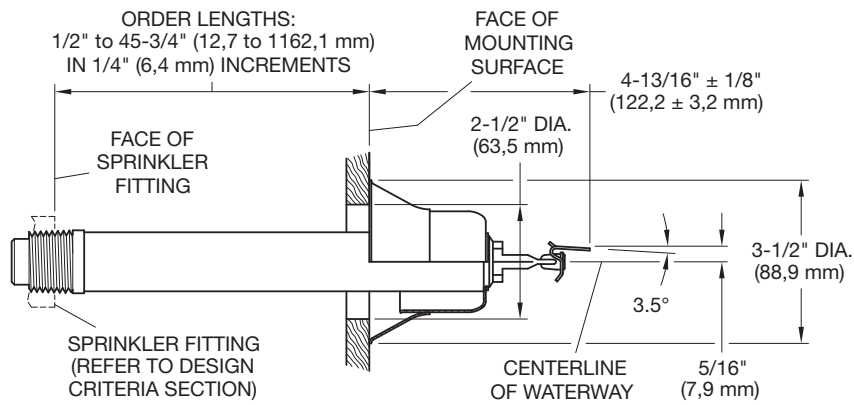

FIGURE 15
STANDARD COVERAGE HORIZONTAL SIDEWALL with DEEP ESCUTCHEON
TY3337 (3 mm Bulb) and TY3357 (5 mm Bulb)

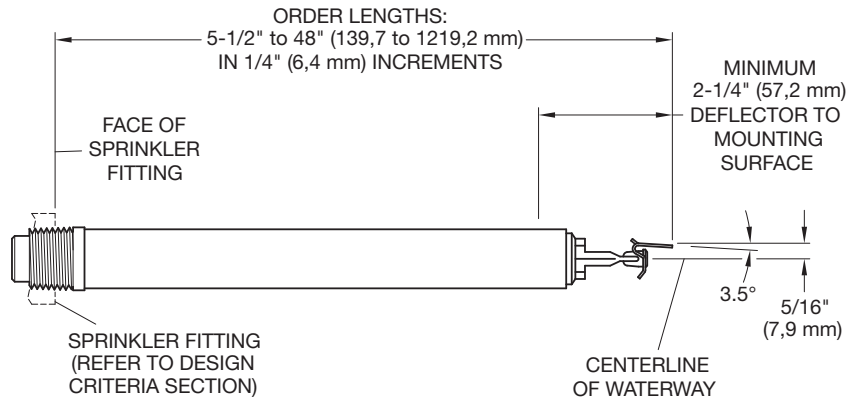

FIGURE 16
STANDARD COVERAGE HORIZONTAL SIDEWALL without ESCUTCHEON
TY3337 (3 mm Bulb) and TY3357 (5 mm Bulb)

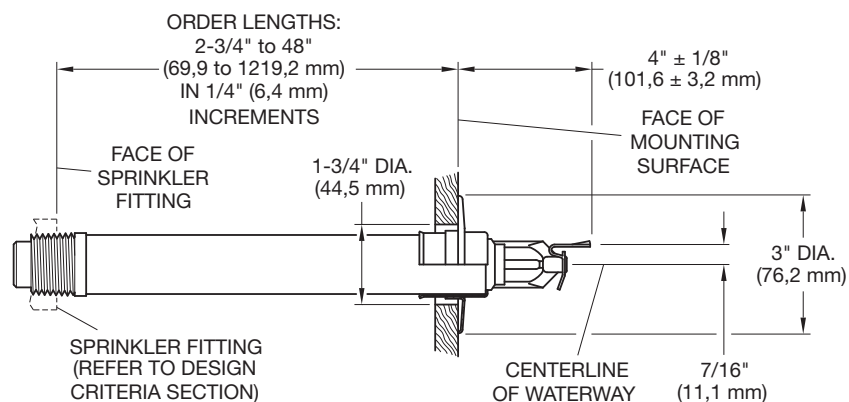

FIGURE 17
SERIES DS-1 STAINLESS STEEL DRY-TYPE EXTENDED COVERAGE
HORIZONTAL SIDEWALL SPRINKLER with STANDARD ESCUTCHEON TY3339 (3 mm Bulb)

Installation

The TYCO Series DS-1 Stainless Steel Dry-Type Sprinklers must be installed in accordance with the following instructions.

NOTICE

The Series DS-1 must only be installed in fittings that meet the requirements of the Design Criteria section. For other important requirements regarding piping design and sealing of the clearance space around the Sprinkler Casing, refer to the Design Criteria section.

Do not install any bulb type sprinkler if the bulb is cracked or there is a loss of liquid from the bulb. With the sprinkler held horizontally, a small air bubble should be present. The diameter of the air bubble is approximately 1/16 inch (1,6 mm) for the 135°F (57°C) rating to 1/8 inch (3,2 mm) for the 286°F (141°C) rating.

Obtain a leak-tight 1-Inch NPT sprinkler joint by applying a minimum-to-maximum torque of 20 to 30 ft.-lbs. (26,8 to 40,2 Nm). Higher levels of torque can distort the sprinkler Inlet with consequent leakage or impairment of the sprinkler.

Do not attempt to compensate for insufficient adjustment in an Escutcheon Plate by under- or over-tightening the Sprinkler. Re-adjust the position of the sprinkler fitting to suit.

Step 1. Install pendent sprinklers only in the pendent position with the deflector parallel to the ceiling. Install horizontal sidewall sprinklers in the horizontal position with their centerline of waterway perpendicular to the back wall and parallel to the ceiling. Ensure the word "TOP" on the Deflector faces the ceiling.

Step 2. With a non-hardening pipe thread sealant such as TEFLON applied to the Inlet threads, hand-tighten the sprinkler into the sprinkler fitting.

Step 3. Wrench-tighten the sprinkler using a pipe wrench on the Inlet Band or Casing (refer to Figures 1 to 3) or using the W-Type 7 Sprinkler Wrench on the Wrench Flat (refer to Figure 9).

Note: *If sprinkler removal becomes necessary, remove the sprinkler using the same wrenching method noted above. Sprinkler removal is easier when a non-hardening sealant was used and torque guidelines were followed. After removal, inspect the sprinkler for damage.*

Step 4. After installing the ceiling or wall and applying a ceiling finish, slide on the outer piece of the Escutcheon until it comes in contact with the ceiling or wall. Do not lift the ceiling panel out of its normal position.

When using the Deep Escutcheon, hold the outer piece in contact with the mounting surface (ceiling or wall). Then rotate the inner piece approximately 1/4 turn, with respect to the outer piece, to hold the Deep Escutcheon firmly together.

Care and Maintenance

The TYCO Series DS-1 Stainless Steel Dry-Type Stainless Steel Sprinklers must be maintained and serviced in accordance with the following instructions.

NOTICE

Before closing a fire protection system main control valve for maintenance work on the fire protection system that it controls, obtain permission to shut down the affected fire protection systems from the proper authorities and notify all personnel who may be affected by this action.

Absence of the outer piece of an escutcheon, which is used to cover a clearance hole, can delay sprinkler operation in a fire situation.

A Vent Hole is provided in the Bulb Seat to indicate if the Dry Sprinkler is remaining dry. (Refer to Figures 1 through 3.) Evidence of leakage from the Vent Hole indicates potential leakage past the Inlet seal and the need to remove the sprinkler to determine the cause of leakage; for example, an improper installation or an ice plug. Close the fire protection system control valve and drain the system before removing the sprinkler.

Exercise care to avoid damage to sprinklers before, during, and after installation. Never paint, plate, coat, or otherwise alter automatic sprinklers after they leave the factory.

Replace sprinklers that:

- were modified or over-heated.
- were damaged by dropping, striking, wrench twisting, wrench slip-page, or the like.
- are leaking or exhibiting visible signs of corrosion.
- were exposed to corrosive products of combustion but have not operated, if you cannot easily remove combustion by-products with a cloth.
- have a cracked bulb or have lost liquid from the bulb. Refer to the Installation section in this data sheet.

Initial and frequent visual inspections of random samples are recommended for corrosion-resistant sprinklers to verify the integrity of the corrosion-resistant material of construction. Thereafter, annual inspections per NFPA 25 should suffice.

Inspections of corrosion-resistant sprinklers are recommended at close range, instead of from the floor level per NFPA. Inspection at close range can better determine the exact sprinkler condition and the long-term integrity of the corrosion-resistant material, which can be affected by the corrosive conditions present.

Responsibility lies with the owner for the inspection, testing, and maintenance of their fire protection system and devices in compliance with this document, as well as with the applicable standards of the National Fire Protection Association (for example, NFPA 25), in addition to the standards of any other Authorities Having Jurisdiction. Contact the installing contractor or sprinkler manufacturer regarding any questions.

Automatic sprinkler systems are recommended to be inspected, tested, and maintained by a qualified Inspection Service in accordance with local requirements and/or national codes.

Limited Warranty

Products manufactured by Tyco Fire Protection Products (TFPP) are warranted solely to the original Buyer for ten (10) years against defects in material and workmanship when paid for and properly installed and maintained under normal use and service. This warranty will expire ten (10) years from date of shipment by TFPP. No warranty is given for products or components manufactured by companies not affiliated by ownership with TFPP or for products and components which have been subject to misuse, improper installation, corrosion, or which have not been installed, maintained, modified or repaired in accordance with applicable Standards of the National Fire Protection Association, and/or the standards of any other Authorities Having Jurisdiction. Materials found by TFPP to be defective shall be either repaired or replaced, at TFPP's sole option. TFPP neither assumes, nor authorizes any person to assume for it, any other obligation in connection with the sale of products or parts of products. TFPP shall not be responsible for sprinkler system design errors or inaccurate or incomplete information supplied by Buyer or Buyer's representatives.

In no event shall TFPP be liable, in contract, tort, strict liability or under any other legal theory, for incidental, indirect, special or consequential damages, including but not limited to labor charges, regardless of whether TFPP was informed about the possibility of such damages, and in no event shall TFPP's liability exceed an amount equal to the sales price.

The foregoing warranty is made in lieu of any and all other warranties, express or implied, including warranties of merchantability and fitness for a particular purpose.

This limited warranty sets forth the exclusive remedy for claims based on failure of or defect in products, materials or components, whether the claim is made in contract, tort, strict liability or any other legal theory.

This warranty will apply to the full extent permitted by law. The invalidity, in whole or part, of any portion of this warranty will not affect the remainder.

Ordering Procedure

To place an order, contact your local distributor. When placing an order, indicate the full product description and Part Number (P/N).

Stainless Steel Dry-Type Sprinklers

1. Specify Sprinkler:

- Model/SIN from the Model/Sprinkler Identification Numbers (SINs) section
- Sprinkler description from the Model/Sprinkler Identification Numbers (SINs) section
- Deflector Style: Pendent or Horizontal Sidewall
- 5.6 K-Factor
- Order Length

Dry-Type Sprinklers are furnished based upon Order Length as measured per Figures 10 through 17, as applicable. Measure the required length and then round the measurement to the nearest 1/4 inch increment.

- Inlet Connections: 1-Inch NPT or ISO 7-R1
- Temperature Rating
Temperature ratings 286°F (141°C) and 360°F (182°C) apply to non-recessed sprinkler assemblies.
- Escutcheon Style, as applicable
- Part Number from Table D

Refer to the price list for a complete listing of part numbers. Part numbers are for 1-Inch NPT standard order sprinklers. Orders for all other sprinkler assemblies must be accompanied by a complete description.

2. Specify Sprinkler Wrench: W-Type 7. Refer to Figure 9.

Dry-Type Sprinkler Boot

Specify Model DSB-2 Dry Sprinkler Boot, P/N 63-000-0-002.

The boot part number includes one Boot, two Strap Ties, and 1/3 oz. of Adhesive. The quantity of adhesive is sufficient for installing one Boot.

P/N* 60 – XXX – X– XXX

		MODEL/ SIN	ORDER LENGTH EXAMPLES (1)			
11	SS Pendent Quick Response w/ Standard Escutcheon (1" NPT)	TY3230 (Figure 10)	055	5.50"		
12	SS Pendent Quick Response w/ Recessed Escutcheon (1" NPT)	TY3230 (Figure 11)	082	8.25"		
13	SS Pendent Quick Response w/ Deep Escutcheon (1" NPT)	TY3230 (Figure 12)	180	18.00"		
14	SS Pendent Quick Response w/o Escutcheon (1" NPT)	TY3230 (Figure 13)	187	18.75"		
			372	37.25"		
			480	48.00"		
FINISH						
21	SS Pendent Standard Response w/ Standard Escutcheon (1" NPT)	TY3250 (Figure 10)	6 Stainless Steel for Sprinkler and Escutcheon			
22	SS Pendent Standard Response w/ Recessed Escutcheon (1" NPT)	TY3250 (Figure 11)				
23	SS Pendent Standard Response w/ Deep Escutcheon (1" NPT)	TY3250 (Figure 12)				
24	SS Pendent Standard Response w/o Escutcheon (1" NPT)	TY3250 (Figure 13)				
15	SS HSW Quick Response Standard Coverage w/ Standard Escutcheon (1" NPT)	TY3337 (Figure 14)			TEMPERATURE RATING (2)	
16	SS HSW Quick Response Standard Coverage w/ Deep Escutcheon (1" NPT)	TY3337 (Figure 15)				
17	SS HSW Quick Response Standard Coverage w/o Escutcheon (1" NPT)	TY3337 (Figure 16)				
25	SS HSW Standard Response Standard Coverage w/ Standard Escutcheon (1" NPT)	TY3357 (Figure 14)				
26	SS HSW Standard Response Standard Coverage w/ Deep Escutcheon (1" NPT)	TY3357 (Figure 15)				
27	SS HSW Standard Response Standard Coverage w/o Escutcheon (1" NPT)	TY3357 (Figure 16)				
18	SS HSW Quick Response Extended Coverage w/ Standard Escutcheon (1" NPT)	TY3339 (Figure 17)				
			0	135°F (57°C)		
			1	155°F (68°C)		
			2	175°F (79°C)		
			3	200°F (93°C)		
			4	286°F (141°C)		
			5	360°F (182°C)		

- Notes**
- * Use Prefix "I" for ISO 7-R1 Connection; for example, I-60-110-6-055.
 - 1. Dry-Type Sprinklers are furnished based upon "Order Length" as measured per Figures 10 through 17 and for each individual sprinkler where it is to be installed. After taking the measurement, round it to the nearest 1/4 inch increment.
 - 2. Temperature ratings 286°F (141°C) and 360°F (182°C) apply to non-recessed sprinkler assemblies.

TABLE D
SERIES DS-1 STAINLESS STEEL DRY-TYPE SPRINKLERS
– PART NUMBER SELECTION –

