

SR-3260LM/RM 32 x 60 Swanstone® Alcove Shower Pan

Model number:

SR03260LM.040

Dimensions: 60" x 32" x 4.3125"

Installation: Alcove

Material: Swanstone®



Standard Features:

- Model Size: 60 L in. X 32 W in. X 6 H in.
- 3 5/16 in. threshold height
- Shower pan comes with a Fit-Flo™ Drain
- Made from high-quality Swanstone solid surface material that resists cracks, chips, and scratches for long-lasting use
- Slip-resistant textured bottom

Product characteristics:

- Designed for tub replacement
- Low Threshold
- Coordinating wall set available

Code Compliant:

ANSI

Standard Colors:



White



Tahiti White



Bone

Certifications

SWAN products adhere to one or more of the following certifications:



SR-3260LM/RM 32 x 60 Swanstone® Alcove Shower Pan

Model number:

SR03260LM.040

Dimensions: 60" x 32" x 4.3125"

Installation: Alcove

Material: Swanstone®

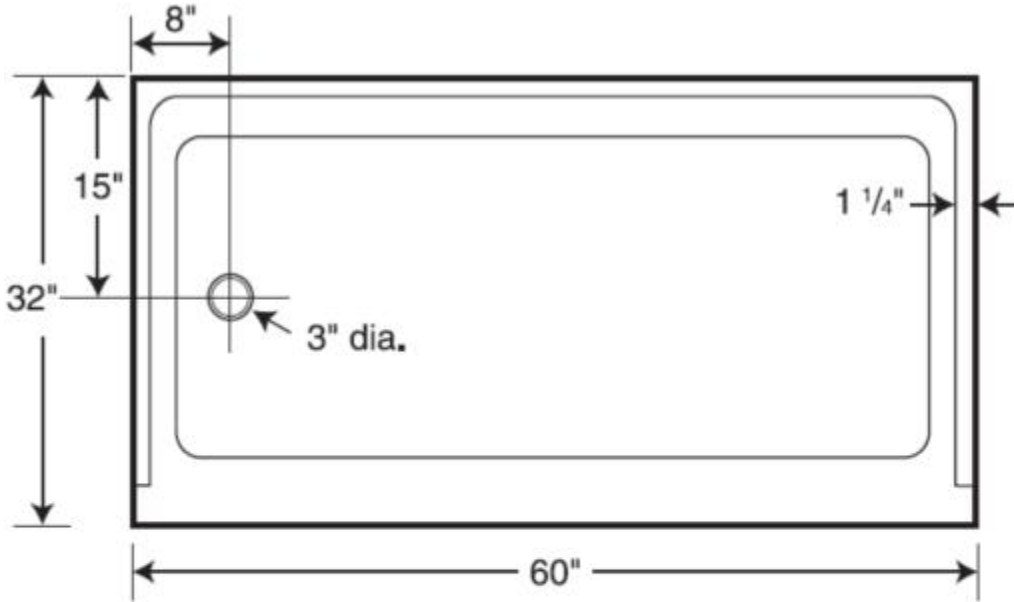

Dimensions

60 x 32 x 4 1/4 In.
(1524 x 813 x 110 mm)

Weight

55 lbs - 25 kg

Shape

Rectangular

Drain location:

Left

Right

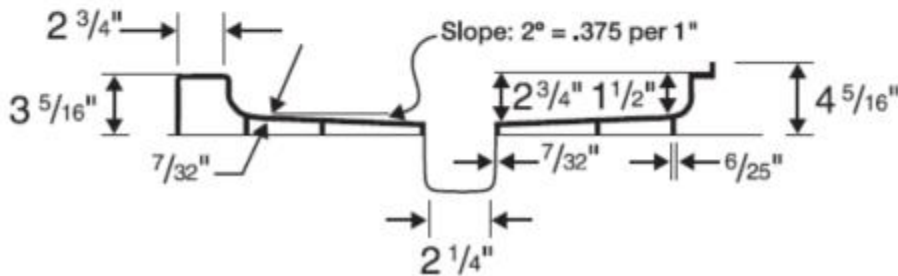

Project:

Contractor:

Representative:

Date:

Tel:

Notes:

