

# TECHNICAL SUPPORT MANUAL

## Split System Heat Pump

### NXH5

#### Safety Labeling and Signal Words

##### DANGER, WARNING, CAUTION, and NOTE

The signal words **DANGER**, **WARNING**, **CAUTION**, and **NOTE** are used to identify levels of hazard seriousness. The signal word **DANGER** is only used on product labels to signify an immediate hazard. The signal words **WARNING**, **CAUTION**, and **NOTE** will be used on product labels and throughout this manual and other manuals that may apply to the product.

**DANGER** - Immediate hazards which **will** result in severe personal injury or death.

**WARNING** - Hazards or unsafe practices which **could** result in severe personal injury or death.

**CAUTION** - Hazards or unsafe practices which **may** result in minor personal injury or product or property damage.

**NOTE** - Used to highlight suggestions which **will** result in enhanced installation, reliability, or operation.

##### Signal Words in Manuals

The signal word **WARNING** is used throughout this manual in the following manner:



The signal word **CAUTION** is used throughout this manual in the following manner:



##### Signal Words on Product Labeling

Signal words are used in combination with colors and/or pictures on product labels.

#### TABLE OF CONTENTS

Model Number Identification .....	2
R-410A Quick Reference Guide .....	3
Charging Chart .....	4
Wiring Diagram .....	5-6
Tech Labels (Expanded Data) .....	7 - 15
Parts List Parts Drawing .....	16 - 21
Cooling Multiplying Factors .....	22 - 58
Heating Multiplying Factors .....	58 - 95

#### MODELS

- NXH518GKA100
- NXH524GKA100
- NXH530GKA100
- NXH536GKA100
- NXH537GKA100
- NXH542GKA100
- NXH548GKA100
- NXH560GKA100

WARNING

**DEATH, PERSONAL INJURY, AND/OR PROPERTY DAMAGE HAZARD**

**Failure to carefully read and follow this warning could result in equipment malfunction, property damage, personal injury and/or death.**

**Installation or repairs made by unqualified persons could result in equipment malfunction, property damage, personal injury and/or death.**

**The information contained in this manual is intended for use by a qualified service technician familiar with safety procedures and equipped with the proper tools and test instruments.**

**Installation must conform with local building codes and with the National Electrical Code NFPA70 current edition or Canadian Electrical Code Part 1 CSA C.22.1.**

<b>OUTDOOR UNIT MODEL NUMBER IDENTIFICATION GUIDE (single phase)</b>											
Digit Position:	1	2	3	4	5, 6	7	8	9	10	11	12
Example Part Number:	<b>N</b>	<b>X</b>	<b>H</b>	<b>5</b>	<b>18</b>	<b>G</b>	<b>K</b>	<b>A</b>	<b>1</b>	<b>0</b>	<b>0</b>
Product Family											
X = R-410A		<b>REFRIGERANT</b>									
A = Air Conditioner											
H = Heat Pump			<b>TYPE</b>								
4 = 14 SEER											
5 = 15 SEER		<b>NOMINAL EFFICIENCY</b>									
18 = 18,000 BTUH = 1-1/2 tons											
24 = 24,000 BTUH = 2 tons											
30 = 30,000 BTUH = 2-1/2 tons											
36 = 36,000 BTUH = 3 tons											
37 = 36,000 BTUH = 3 tons											
42 = 42,000 BTUH = 3-1/2 tons											
48 = 48,000 BTUH = 4 tons											
60 = 60,000 BTUH = 5 tons			<b>NOMINAL CAPACITY</b>								
A = Standard Grille											
G = Coil Guard Grille											
C = Coastal											
						<b>FEATURES</b>					
K = 208/230-1-60							<b>VOLTAGE</b>				
Sales Code											
Engineering Revision											
Extra Digit											
Extra Digit											

<b>ACCESSORIES PART NUMBER IDENTIFICATION GUIDE</b>											
Digit Position:	1	2	3	4	5	6, 7	8, 9	10, 11			
Example Part Number:	<b>N</b>	<b>A</b>	<b>S</b>	<b>A</b>	<b>0</b>	<b>01</b>	<b>01</b>	<b>CH</b>			
N = Non-Branded		<b>BRANDING</b>									
A = Accessory			<b>PRODUCT GROUP</b>								
S = Split System (AC & HP)			<b>KIT USAGE</b>								
A = Original											
B = 2nd Generation											
						<b>MAJOR SERIES</b>					
0 = Generic or Not Applicable											
2 = R-22											
4 = R-410A			<b>REFRIGERANT</b>								
Product Identifier Number											
Package Quantity											
Type of Kit(Example: CH = Crankcase Heater)											

## R-410A QUICK REFERENCE GUIDE

---

- R-410A refrigerant operates at 50% – 70% higher pressures than R-22. Be sure that servicing equipment and replacement components are designed to operate with R-410A.
- R-410A refrigerant cylinders are rose colored.
- Recovery cylinder service pressure rating must be 400 psig, DOT 4BA400 or DOT BW400.
- R-410A systems should be charged with liquid refrigerant. Use a commercial type metering device in the manifold hose when charging into suction line with compressor operating.
- Manifold sets should be 750 psig high-side and 200 psig low-side with 520 psig low-side retard.
- Use hoses with 750 psig service pressure rating.
- Leak detectors should be designed to detect HFC refrigerant.
- R-410A, as with other HFC refrigerants, is only compatible with POE oils.
- Vacuum pumps will not remove moisture from oil.
- Do not use liquid line filter-driers with rated working pressures less than 600 psig.
- Do not install a suction line filter-drier in liquid line.
- POE oils absorb moisture rapidly. Do not expose oil to atmosphere.
- POE oils may cause damage to certain plastics and roofing materials.
- Wrap all filter-driers and service valves with wet cloth when brazing.
- A liquid line filter-drier is required on every unit.
- Do not use with an R-22 TXV.
- If indoor unit is equipped with an R-22 TXV, it must be changed to an R-410A TXV.
- Never open system to atmosphere while it is under a vacuum.
- When system must be opened for service, break vacuum with dry nitrogen and replace all filter-driers. Evacuate to 500 microns before recharging.
- Do not vent R-410A into the atmosphere.
- Do not use capillary tube indoor coils.
- Observe all **WARNINGS**, **CAUTIONS**, **NOTES**, and **bold** text.

R-410A CHARGING CHART												
Measured Liquid Pressure (psig)	Rating Plate (required) Subcooling Temperature °F (°C)											
	°F	(°C)	°F	(°C)	°F	(°C)	°F	(°C)	F	(°C)	F	(°C)
	6	3	8	4	10	6	12	7	14	8	16	9
R-410A Required Liquid Line Temperature °F (°C)												
251	78	26	76	24	74	23	72	22	70	21	68	20
259	80	27	78	26	76	24	74	23	72	22	70	21
266	82	28	80	27	78	26	76	24	74	23	72	22
274	84	29	82	28	80	27	78	26	76	24	74	23
283	86	30	84	29	82	28	80	27	78	26	76	24
291	88	31	86	30	84	29	82	28	80	27	78	26
299	90	32	88	31	86	30	84	29	82	28	80	27
308	92	33	90	32	88	31	86	30	84	29	82	28
317	94	34	92	33	90	32	88	31	86	30	84	29
326	96	36	94	34	92	33	90	32	88	31	86	30
335	98	37	96	36	94	34	92	33	90	32	88	31
345	100	38	98	37	96	36	94	34	92	33	90	32
364	104	40	102	39	100	38	98	37	96	36	94	34
374	106	41	104	40	102	39	100	38	98	37	96	36
384	108	42	106	41	104	40	102	39	100	38	98	37
395	110	43	108	42	106	41	104	40	102	39	100	38
406	112	44	110	43	108	42	106	41	104	40	102	39
416	114	46	112	44	110	43	108	42	106	41	104	40
427	116	47	114	46	112	44	110	43	108	42	106	41
439	118	48	116	47	114	46	112	44	110	43	108	42
450	120	49	118	48	116	47	114	46	112	44	110	43
462	122	50	120	49	118	48	116	47	114	46	112	44
474	124	51	122	50	120	49	118	48	116	47	114	46

Model Sizes: 18, 24, 30, 36, 37, 42, 48, 60

CONNECTION DIAGRAM

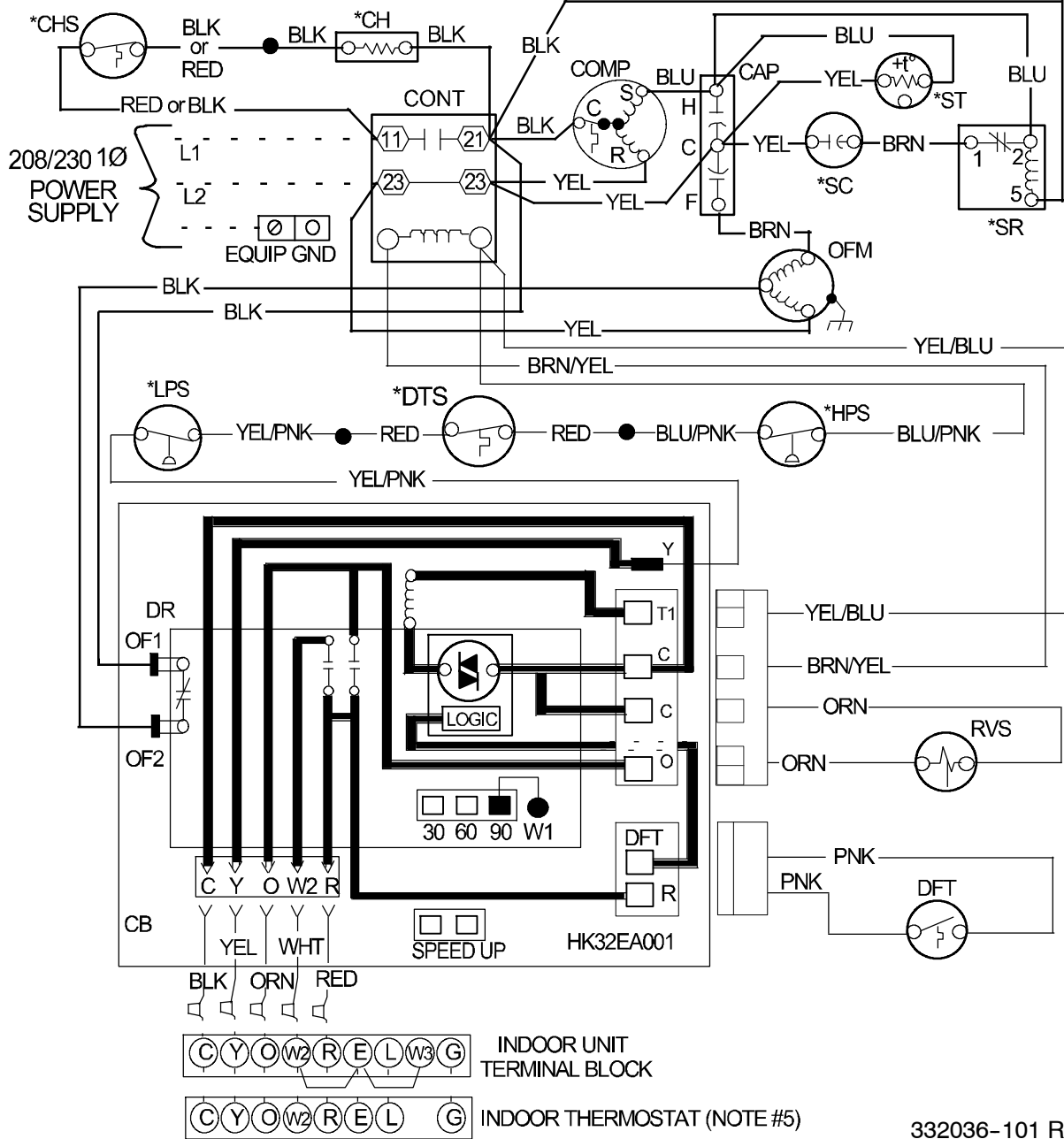

332036-101 Rev. D

1. Symbols are electrical representation only.
2. Compressor and fan motor furnished with inherent thermal protection.
3. To be wired in accordance with National Electric N.E.C. and local codes.
4. N.E.C. class 2, 24 V circuit, min. 40 VA required, 60 VA on units installed with LLS.
5. Connection for typical heat pump thermostat. For other arrangements see installation instructions.
6. Use copper conductors only. Use conductors suitable for at least 75° C (167° F).
7. If indoor section has a transformer with a grounded secondary, connect the grounded side to "C" on the circuit board.
8. When start capacitor and relay are installed, start thermistor (PTC) is not used.
9. CH not used on all units.
10. If any of the original wire, as supplied, must be replaced, use the same or equivalent wire.
11. Check all electrical connections inside control box for tightness.
12. Do not attempt to operate unit until service valves have been opened.
13. Do not rapid cycle compressor. Compressor must be off 3 minutes to allow pressures to equalize between high and low side before starting.

Model Sizes: 18, 24, 30, 36, 37, 42, 48, 60

**SCHEMATIC DIAGRAM (LADDER FORM)**

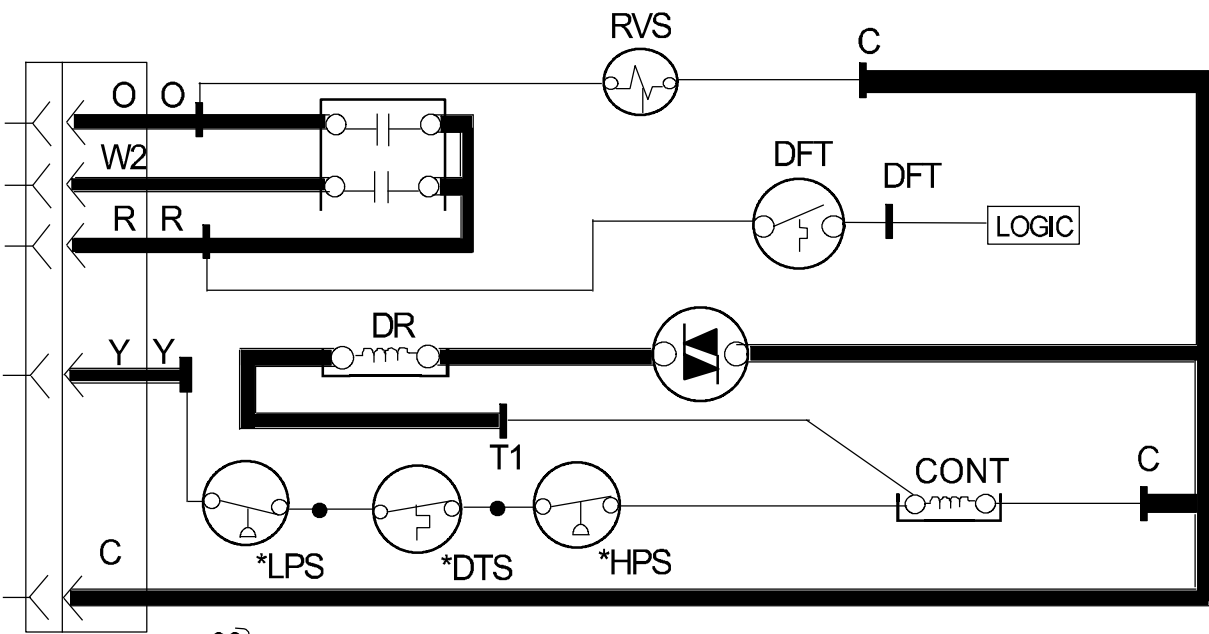
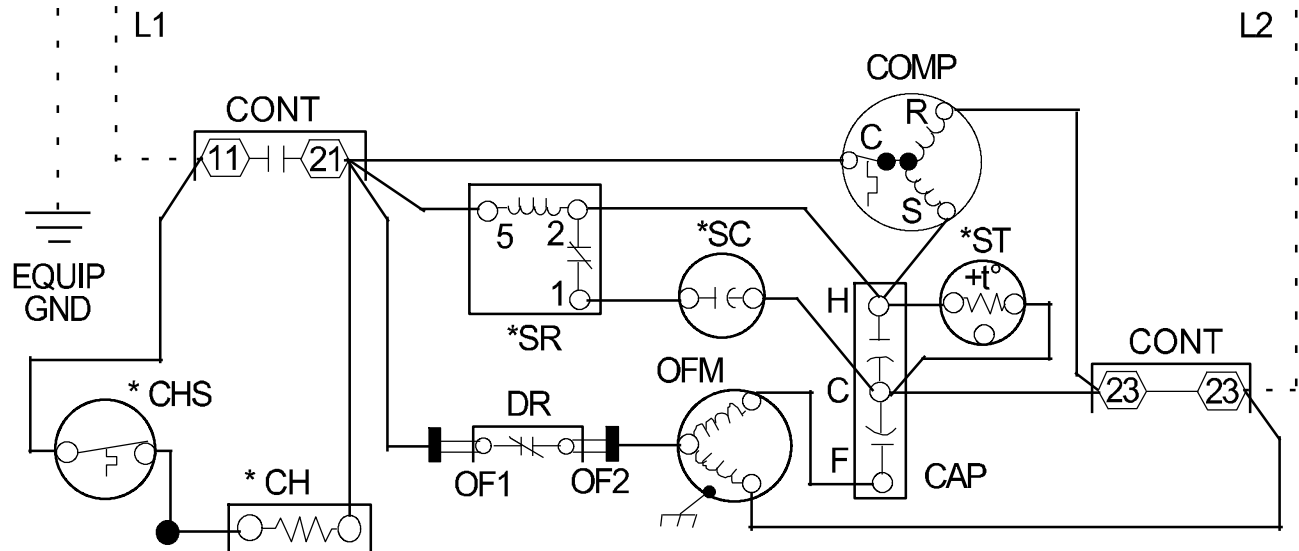

90 } FIELD SELECTED TIME PERIOD  
 60 } BETWEEN DEFROST CYCLES (MINUTES)  
 30 }

SPEED UP   JUMPERED TEST PINS (USE METAL OBJECT), FIELD SPEED-UP CYCLE  
 HEAT CYCLE: 90 MIN. ACCELERATED TO 21 SEC.  
 60 MIN. ACCELERATED TO 14 SEC.  
 30 MIN. ACCELERATED TO 7 SEC.  
 DEFROST CYCLE: 10 MIN. ACCELERATED TO 2 SEC.

332036-101 Rev. D

**-LEGEND-**

- |     |                            |      |                             |      |                          |
|-----|----------------------------|------|-----------------------------|------|--------------------------|
| —   | FACTORY POWER WIRING       | CAP  | CAPACITOR (DUAL RUN)        | *DTS | DISCHARGE TEMP. SWITCH   |
| - - | FIELD POWER WIRING         | *CH  | CRANKCASE HEATER            | *HPS | HIGH PRESSURE SWITCH     |
| —   | FACTORY CONTROL WIRING     | *CHS | CRANKCASE HEATER SWITCH     | *LPS | LOW PRESSURE SWITCH      |
| - - | FIELD CONTROL WIRING       | COMP | COMPRESSOR                  | OFM  | OUTDOOR FAN MOTOR        |
| —   | CONDUCTOR ON CIRCUIT BOARD | CONT | CONTACTOR                   | RVS  | REVERSING VALVE SOLENOID |
| ○   | COMPONENT CONNECTION       | CB   | CIRCUIT BOARD               | *SC  | START CAPACITOR          |
| —   | 1/4 INCH QUICK CONNECT     | DFT  | DEFROST THERMOSTAT          | *SR  | START RELAY              |
| ○   | TERMINALS                  | DR   | DEFROST RELAY AND CIRCUITRY | *ST  | START THERMISTOR         |
| ⌋   | FIELD SPICE                |      |                             |      |                          |
| ●   | JUNCTION                   |      |                             |      |                          |

\* MAY BE FACTORY OR FIELD INSTALLED

## MULTIPLYING FACTORS

- † Total capacities are net (I.D. blower heat subtracted) system capacities based on 25' line set. If additional tubing length and/or indoor unit is located above outdoor unit, a slight variation in capacity may occur.
- †† At TVA rating indoor condition (75 ° F db, 63 ° F wb), all other indoor air temperatures are at 80 ° F db. If additional tubing length and/or indoor unit is located above outdoor unit, a slight variation in capacity may occur.
- \* System amps are total of indoor and outdoor amps.
- ‡ Chart data is for 80° F indoor dry bulb. For indoor db temperatures other than 80° F, measure Indoor db and Indoor CFM, and plug these into the formula below. Measure outdoor db and indoor wet bulb, apply these to the chart above, find MBh and S/T, and plug these into the formula below. (Note: if indoor db is the only thing changing, total capacity, MBh, stays the same.)

$$\text{Sensible Capacity at Indoor db LOWER than } 80 \text{ } ^\circ \text{F} = (\text{MBh} \times \text{S/T}) - \left( \frac{(\text{80} - \text{Indoor db}) \times 835 \times \text{Indoor CFM}}{1000} \right)$$

$$\text{Sensible Capacity at Indoor db HIGHER than } 80 \text{ } ^\circ \text{F} = (\text{MBh} \times \text{S/T}) + \left( \frac{(\text{Indoor db} - 80) \times 835 \times \text{Indoor CFM}}{1000} \right)$$

COOLING		18 Size Outdoor With FXM4X18*** Indoor Cooling																							
		Outdoor Ambient Temperature - Degrees F, Dry Bulb								Entering Indoor Temperature - Degrees F, Wet Bulb															
		75				85				95				105					115						
CFM	72	67	63††	62	57	72	67	63††	62	57	72	67	63††	62	57	72	67	63††	62	57					
	21.38	19.37	17.92	17.54	16.80	20.34	18.43	17.05	16.69	16.15	19.25	17.43	16.12	15.79	15.45	18.10	16.38	15.14	14.85	14.70	16.88	15.26	14.10	13.91	13.89
MBh†	0.52	0.70	0.73	0.91	1.00	0.53	0.71	0.74	0.93	1.00	0.53	0.73	0.76	0.95	1.00	0.54	0.75	0.78	0.98	1.00	0.56	0.77	0.80	1.00	1.00
S/T†	4.77	4.78	4.79	4.80	4.80	5.45	5.44	5.44	5.44	5.44	6.17	6.15	6.13	6.13	6.13	6.95	6.92	6.90	6.89	6.89	7.83	7.78	7.76	7.76	7.76
AMPS*	2.68	2.66	2.64	2.64	2.63	3.11	3.08	3.06	3.06	3.05	3.57	3.54	3.52	3.51	3.50	4.07	4.04	4.01	4.01	4.00	4.62	4.59	4.56	4.55	4.55
HI PR	157	143	133	131	126	159	146	136	133	129	162	148	138	136	133	164	150	140	138	137	167	153	143	141	141
LO PR	21.87	19.84	18.37	18.01	17.61	20.79	18.85	17.45	17.13	16.90	19.64	17.80	16.48	16.21	16.15	18.44	16.70	15.45	15.36	15.34	17.17	15.54	14.37	14.49	14.47
MBh†	0.53	0.73	0.75	0.95	1.00	0.54	0.74	0.77	0.97	1.00	0.55	0.76	0.79	0.99	1.00	0.56	0.79	0.81	1.00	1.00	0.58	0.82	0.84	1.00	1.00
S/T†	4.81	4.82	4.83	4.83	4.84	5.50	5.49	5.48	5.48	5.48	6.22	6.19	6.18	6.17	6.17	7.00	6.96	6.94	6.94	6.94	7.88	7.83	7.81	7.81	7.81
AMPS*	2.69	2.67	2.65	2.65	2.64	3.12	3.09	3.07	3.06	3.06	3.58	3.55	3.52	3.52	3.52	4.08	4.05	4.02	4.02	4.02	4.63	4.59	4.57	4.57	4.57
HI PR	160	147	137	135	132	163	149	139	137	135	165	151	141	139	139	168	154	143	143	143	170	156	145	147	147
LO PR	22.26	20.21	18.73	18.42	18.29	21.13	19.17	17.76	17.56	17.54	19.94	18.08	16.76	16.74	16.74	18.70	16.95	15.70	15.90	15.88	17.39	15.75	14.58	14.98	14.96
MBh†	0.55	0.76	0.78	0.99	1.00	0.56	0.78	0.80	1.00	1.00	0.57	0.80	0.83	1.00	1.00	0.59	0.83	0.85	1.00	1.00	0.60	0.86	0.88	1.00	1.00
S/T†	4.85	4.86	4.87	4.87	4.87	5.54	5.53	5.53	5.52	5.52	6.27	6.24	6.22	6.22	6.22	7.06	7.01	6.99	6.99	6.99	7.93	7.88	7.85	7.86	7.86
AMPS*	2.70	2.67	2.66	2.65	2.65	3.12	3.09	3.07	3.07	3.07	3.58	3.55	3.53	3.53	3.53	4.09	4.05	4.03	4.03	4.03	4.64	4.60	4.57	4.58	4.58
HI PR	163	150	139	138	137	166	152	141	140	140	168	154	143	144	144	170	156	145	148	147	172	158	148	152	152
LO PR																									

HEATING		18 Size Outdoor With FXM4X18*** Indoor Heating																												
		Outdoor Ambient Temperature - Degrees F, Dry Bulb								Entering Indoor Temperature - Degrees F, Dry Bulb																				
		-3				7				17				37				47					57					67		
CFM	65	70	75	65	70	75	65	70	75	65	70	75	65	70	75	65	70	75	65	70	75	65	70	75	65	70	75			
	5.13	4.84	4.50	7.34	7.04	6.70	9.76	9.43	9.09	12.54	12.28	11.98	15.15	14.86	14.56	18.08	17.74	17.39	21.28	20.89	20.50	24.14	23.84	23.52	27.00	26.60	26.20	25.80		
MBh†	9.50	8.90	8.30	13.60	13.00	12.30	18.00	17.40	16.70	23.20	22.60	22.00	28.00	27.40	26.80	33.40	32.70	32.00	39.30	38.50	37.70	44.60	44.00	43.30	50.60	49.80	49.00	48.20		
T/R	4.44	4.64	4.84	4.67	4.88	5.10	4.89	5.12	5.35	5.15	5.41	5.67	5.41	5.68	5.96	5.74	6.02	6.30	6.12	6.43	6.74	6.42	6.75	7.08	6.80	6.60	6.40	6.20		
AMPS*	2.17	2.32	2.48	2.32	2.47	2.64	2.48	2.65	2.81	2.69	2.86	3.04	2.90	3.08	3.27	3.15	3.34	3.53	3.43	3.63	3.83	3.65	3.86	4.07	3.80	3.60	3.40	3.20		
HI PR	39	40	40	50	51	51	63	63	64	77	77	78	94	94	94	112	112	113	132	133	133	149	149	151	152	152	152	152		
LO PR	5.22	4.92	4.59	7.46	7.15	6.82	9.91	9.58	9.24	12.68	12.44	12.15	15.35	15.05	14.75	18.35	18.00	17.65	21.43	21.15	20.82	24.11	23.87	23.58	27.00	26.60	26.20	25.80		
MBh†	8.40	7.90	7.40	12.10	11.50	11.00	16.00	15.50	14.90	20.50	20.10	19.60	24.80	24.30	23.80	29.70	29.10	28.40	34.70	34.10	33.50	39.00	38.50	38.00	44.60	44.00	43.30	42.70		
T/R	4.44	4.64	4.85	4.65	4.86	5.08	4.85	5.08	5.31	5.07	5.33	5.59	5.30	5.57	5.85	5.60	5.88	6.16	5.88	6.19	6.52	6.16	6.48	6.81	6.50	6.30	6.10	5.90		
AMPS*	2.14	2.29	2.45	2.27	2.43	2.59	2.42	2.59	2.76	2.60	2.78	2.96	2.80	2.98	3.16	3.03	3.21	3.40	3.24	3.45	3.66	3.46	3.66	3.87	3.50	3.30	3.10	2.90		
HI PR	39	40	40	50	51	51	63	63	64	77	77	78	93	94	94	112	112	113	130	132	133	146	148	150	152	152	152	152		
LO PR	5.30	4.99	4.66	7.55	7.25	6.92	10.04	9.71	9.36	12.80	12.56	12.29	15.51	15.21	14.91	18.56	18.21	17.86	21.37	21.20	20.95	23.93	23.75	23.53	27.00	26.60	26.20	25.80		
MBh†	7.60	7.20	6.70	10.90	10.40	9.90	14.40	13.90	13.40	18.40	18.00	17.60	22.30	21.80	21.30	26.70	26.10	25.60	30.70	30.40	30.00	34.40	34.10	33.70	39.00	38.50	38.00	37.50		
T/R	4.46	4.65	4.86	4.64	4.86	5.08	4.82	5.05	5.29	5.02	5.27	5.54	5.23	5.49	5.77	5.50	5.78	6.06	5.71	6.02	6.34	5.97	6.29	6.61	6.30	6.10	5.90	5.70		
AMPS*	2.12	2.27	2.43	2.24	2.40	2.56	2.37	2.54	2.71	2.54	2.71	2.89	2.72	2.90	3.08	2.93	3.11	3.30	3.11	3.31	3.52	3.30	3.51	3.72	3.40	3.20	3.00	2.80		
HI PR	39	40	40	50	51	51	63	63	63	77	77	78	93	94	94	111	112	112	128	130	131	143	145	147	147	147	147	147	147	
LO PR																														



COOLING		24 Size Outdoor With FXM4X24*** Indoor Cooling																			
		Outdoor Ambient Temperature - Degrees F, Dry Bulb																			
		75					85					105					115				
CFM	72	67	63†	62	57	72	67	63†	62	57	72	67	63†	62	57	72	67	63†	62	57	
700	MBh†	28.25	25.63	23.76	23.28	22.30	27.04	24.52	22.71	22.25	21.50	25.76	23.33	21.59	21.17	20.65	24.38	22.05	20.38	20.00	19.72
	S/T†	0.52	0.70	0.73	0.91	1.00	0.53	0.73	0.74	0.93	1.00	0.53	0.73	0.75	0.95	1.00	0.54	0.74	0.77	0.97	1.00
	AMPS*	6.54	6.42	6.36	6.36	6.35	7.39	7.26	7.20	7.20	7.18	8.31	8.18	8.12	8.11	8.11	9.33	9.20	9.15	9.14	9.14
	HIPR	266	264	262	262	261	308	306	304	303	302	354	351	349	348	348	405	401	399	398	398
	LO PR	153	140	130	128	123	155	142	132	130	126	157	144	134	132	129	160	146	136	134	133
800	MBh†	28.87	26.21	24.31	23.85	23.30	27.60	25.04	23.21	22.80	22.45	26.26	23.80	22.04	21.69	21.53	24.83	22.47	20.78	20.58	20.55
	S/T†	0.53	0.73	0.75	0.95	1.00	0.54	0.74	0.77	0.97	1.00	0.55	0.76	0.79	0.99	1.00	0.56	0.78	0.81	1.00	
	AMPS*	6.66	6.52	6.45	6.44	6.44	7.51	7.36	7.29	7.28	7.28	8.42	8.28	8.21	8.20	8.20	9.44	9.30	9.24	9.23	
	HIPR	267	264	263	262	262	309	306	304	304	304	355	352	350	349	349	406	402	400	399	
	LO PR	156	143	133	131	128	158	145	135	133	131	160	147	137	135	134	163	149	139	138	
900	MBh†	29.34	26.65	24.73	24.35	24.14	28.03	25.44	23.59	23.29	23.24	26.65	24.16	22.39	22.31	22.28	25.17	22.79	21.09	21.27	21.24
	S/T†	0.55	0.76	0.78	0.99	1.00	0.56	0.77	0.80	1.00	1.00	0.57	0.79	0.82	1.00	1.00	0.58	0.82	0.84	1.00	
	AMPS*	6.78	6.62	6.54	6.53	6.53	7.62	7.46	7.38	7.38	7.37	8.54	8.38	8.30	8.30	8.30	9.55	9.40	9.32	9.33	
	HIPR	267	265	263	263	263	310	307	305	305	304	356	353	350	350	350	407	403	400	401	
	LO PR	159	146	136	134	133	161	148	137	136	136	163	149	139	139	139	165	152	141	143	

HEATING		24 Size Outdoor With FXM4X24*** Indoor Heating																											
		Outdoor Ambient Temperature - Degrees F, Dry Bulb																											
		-3					7					17					47					57					67		
CFM	65	70	75	65	70	75	65	70	75	65	70	75	65	70	75	65	70	75	65	70	75								
700	MBh†	8.38	7.98	7.57	11.07	10.69	10.29	14.28	13.97	13.23	17.14	16.84	16.55	20.39	20.05	19.70	24.08	23.68	23.28	28.29	27.81	27.36							
	T/R	12.00	11.40	10.80	15.90	15.30	14.70	20.50	20.00	18.90	24.60	24.10	23.70	29.30	28.70	28.20	34.60	33.90	33.30	40.60	39.90	39.10							
	AMPS*	5.92	6.19	6.49	6.28	6.58	6.90	6.59	6.93	7.22	6.82	7.17	7.54	7.09	7.46	7.84	7.49	7.87	8.27	8.09	8.48	8.88							
	HIPR	225	240	256	240	256	272	260	277	291	279	296	315	302	320	339	330	349	368	365	384	404							
	LO PR	38	38	38	49	49	50	62	62	62	62	76	76	77	93	93	111	111	112	131	132								
800	MBh†	8.52	8.12	7.71	11.24	10.86	10.46	14.45	14.15	13.44	17.34	17.04	16.74	20.64	20.30	19.94	24.41	24.00	23.59	28.68	28.21	27.76							
	T/R	10.70	10.20	9.60	14.10	13.60	13.10	18.20	17.70	16.80	21.80	21.40	20.90	25.90	25.40	24.90	30.70	30.10	29.50	36.00	35.40	34.70							
	AMPS*	5.93	6.21	6.50	6.26	6.56	6.88	6.53	6.87	7.16	6.72	7.07	7.44	6.96	7.32	7.70	7.33	7.69	8.08	7.88	8.26								
	HIPR	222	237	253	235	251	268	253	270	285	270	288	306	292	310	329	318	337	356	350	369								
	LO PR	38	38	38	49	49	50	61	62	62	76	76	77	92	93	111	111	112	131	132									
900	MBh†	8.64	8.24	7.82	11.39	11.00	10.60	14.59	14.30	13.66	17.50	17.21	16.91	20.85	20.50	20.15	24.67	24.26	23.85	28.96	28.53	28.05							
	T/R	9.60	9.20	8.70	12.70	12.30	11.80	16.30	15.90	15.20	19.50	19.20	18.80	23.30	22.90	22.40	27.50	27.00	26.50	32.30	31.80	31.20							
	AMPS*	5.95	6.23	6.53	6.26	6.56	6.88	6.50	6.84	7.14	6.66	7.01	7.38	6.87	7.23	7.61	7.22	7.58	7.96	7.71	8.12								
	HIPR	219	234	250	232	248	264	247	264	280	264	281	299	284	302	320	309	327	346	337	358								
	LO PR	38	38	38	49	49	49	61	62	62	76	76	76	92	93	111	111	111	111	130									

COOLING		30 Size Outdoor With FXM4X30*** Indoor Cooling																							
		Outdoor Ambient Temperature - Degrees F, Dry Bulb								Entering Indoor Temperature - Degrees F, Wet Bulb															
		75				85				95				105					115						
CFM	72	67	63†	62	57	72	67	63†	62	57	72	67	63†	62	57	72	67	63†	62	57					
	34.40	31.23	28.95	28.38	27.40	32.81	29.80	27.62	27.09	26.39	31.16	28.29	26.22	25.75	25.32	29.42	26.69	24.73	24.33	24.15	27.55	24.96	23.11	22.91	22.88
	0.52	0.70	0.72	0.91	1.00	0.52	0.71	0.74	0.93	1.00	0.53	0.73	0.75	0.95	1.00	0.54	0.75	0.77	0.98	1.00	0.55	0.77	0.80	1.00	1.00
875	7.97	7.91	7.88	7.87	7.86	8.92	8.85	8.81	8.81	8.80	9.97	9.90	9.85	9.85	9.84	11.15	11.08	11.05	11.04	11.04	12.49	12.44	12.42	12.41	12.41
	271	268	266	266	265	314	310	308	307	307	360	356	354	353	352	411	407	404	403	403	467	462	459	459	459
	156	143	133	130	126	158	145	135	133	129	160	147	137	135	133	163	149	139	137	136	165	152	141	141	141
	35.08	31.88	29.57	29.06	28.58	33.43	30.37	28.18	27.73	27.49	31.71	28.80	26.71	26.39	26.34	29.89	27.13	25.16	25.13	25.10	27.95	25.35	23.49	23.77	23.74
	0.53	0.73	0.75	0.95	1.00	0.54	0.74	0.77	0.97	1.00	0.55	0.76	0.79	1.00	1.00	0.56	0.79	0.81	1.00	1.00	0.57	0.81	0.84	1.00	1.00
1000	8.09	8.03	7.99	7.99	7.98	9.05	8.97	8.93	8.92	8.92	10.09	10.02	9.97	9.97	9.96	11.27	11.20	11.16	11.16	11.16	12.61	12.55	12.53	12.53	12.53
	272	269	267	266	266	315	311	309	308	308	361	357	354	354	354	412	408	405	405	405	468	463	460	461	461
	159	146	136	134	132	161	148	138	136	135	164	150	140	138	138	166	152	142	142	142	168	154	144	144	146
	35.61	32.37	30.05	29.68	29.56	33.89	30.81	28.60	28.45	28.41	32.11	29.18	27.09	27.22	27.19	30.24	27.47	25.49	25.91	25.88	28.25	25.64	23.78	24.49	24.46
	0.55	0.76	0.78	0.99	1.00	0.56	0.78	0.80	1.00	1.00	0.57	0.80	0.82	1.00	1.00	0.58	0.82	0.85	1.00	1.00	0.60	0.85	0.88	1.00	1.00
1125	8.21	8.14	8.11	8.10	8.10	9.17	9.09	9.04	9.04	9.04	10.22	10.14	10.09	10.09	10.09	11.39	11.32	11.28	11.28	11.28	12.72	12.67	12.64	12.65	12.65
	272	269	267	267	267	315	312	309	309	309	362	358	355	355	355	413	409	406	406	406	469	464	461	462	462
	162	148	138	137	137	164	150	140	140	140	166	152	142	143	143	168	154	144	144	147	170	157	146	150	150

HEATING		30 Size Outdoor With FXM4X30*** Indoor Heating																							
		Outdoor Ambient Temperature - Degrees F, Dry Bulb								Entering Indoor Temperature - Degrees F, Dry Bulb															
		-3				7				17				27				37					47	57	67
CFM	65	70	75	65	70	75	65	70	75	65	70	75	65	70	75	65	70	75	65	70	75	65	70	75	
	9.76	9.22	8.65	13.14	12.63	12.09	16.80	16.30	15.76	21.11	20.75	20.33	25.07	24.68	24.28	29.50	29.04	28.57	34.45	33.93	33.39	39.00	38.55	38.09	38.09
	10.50	9.90	9.20	14.10	13.50	12.90	18.00	17.40	16.80	22.60	22.20	21.70	26.90	26.40	25.90	31.60	31.00	30.50	36.90	36.30	35.60	41.80	41.20	40.60	40.60
875	6.92	7.24	7.57	7.23	7.56	7.91	7.54	7.90	8.28	7.94	8.34	8.75	8.32	8.73	9.17	8.78	9.20	9.66	9.29	9.78	10.28	9.74	10.22	10.72	10.72
	221	236	251	235	250	267	251	267	284	272	290	308	293	311	330	317	336	356	344	366	387	367	388	409	409
	37	38	38	48	48	49	60	61	61	74	75	75	90	91	91	108	109	109	127	128	129	144	145	147	147
	9.94	9.40	8.83	13.35	12.84	12.30	17.06	16.55	16.02	21.33	20.99	20.59	25.37	24.96	24.56	29.87	29.40	28.93	34.61	34.27	33.82	38.97	38.59	38.19	38.19
	9.30	8.80	8.20	12.50	12.00	11.50	16.00	15.50	14.90	20.00	19.60	19.20	23.80	23.30	22.90	28.00	27.50	27.00	32.40	32.10	31.60	36.50	36.10	35.60	35.60
	6.96	7.28	7.61	7.24	7.57	7.93	7.52	7.88	8.26	7.87	8.27	8.67	8.20	8.62	9.05	8.62	9.05	9.49	9.01	9.48	9.97	9.44	9.91	10.40	10.40
1000	2.18	233	248	230	246	263	245	261	278	264	282	300	283	301	320	306	325	344	327	348	369	349	370	391	391
	37	38	38	48	48	49	60	61	61	74	75	75	90	91	91	108	108	109	126	127	128	142	143	144	144
	10.10	9.56	8.98	13.53	13.03	12.48	17.28	16.77	16.23	21.54	21.18	20.81	25.61	25.20	24.80	30.18	29.70	29.22	34.65	34.31	33.98	38.83	38.50	38.16	38.16
	8.40	7.90	7.40	11.30	10.80	10.40	14.40	13.90	13.50	17.90	17.60	17.30	21.30	21.00	20.60	25.10	24.70	24.20	28.90	28.50	28.20	32.40	32.00	31.60	31.60
1125	7.02	7.34	7.67	7.27	7.61	7.96	7.52	7.89	8.26	7.84	8.23	8.64	8.14	8.55	8.97	8.53	8.95	9.39	8.84	9.29	9.77	9.24	9.70	10.18	10.18
	215	231	246	227	243	260	240	257	274	258	275	294	276	294	313	297	316	335	315	335	356	335	356	377	377
	37	38	38	48	48	49	60	61	61	74	74	74	90	90	91	108	108	108	124	125	127	139	141	141	142

COOLING		36 Size Outdoor With FXM4X36*** Indoor Cooling																								
		Outdoor Ambient Temperature - Degrees F, Dry Bulb										Outdoor Ambient Temperature - Degrees F, Wet Bulb														
		75					85					95					105					115				
CFM	72	67	63†	62	57	72	67	63†	62	57	72	67	63†	62	57	72	67	63†	62	57	72	67	63†	62	57	
1050	MBh†	41.59	37.90	35.22	34.53	33.22	39.75	36.20	33.62	32.97	32.01	37.77	34.37	31.90	31.31	30.68	35.67	32.42	30.07	29.55	29.25	33.40	30.32	28.09	27.74	27.70
	S/T†	0.53	0.72	0.74	0.93	1.00	0.54	0.73	0.76	0.95	1.00	0.54	0.74	0.77	0.97	1.00	0.55	0.76	0.79	1.00	1.00	0.57	0.79	0.81	1.00	1.00
	AMPS*	9.76	9.68	9.63	9.62	9.60	10.90	10.80	10.73	10.72	10.70	12.14	12.03	11.96	11.94	11.92	13.54	13.42	13.35	13.33	13.32	15.12	15.01	14.95	14.95	14.94
	HIPR	273	270	268	267	266	316	312	310	309	308	363	359	356	355	354	415	410	406	406	405	470	465	462	461	461
	LO PR	155	142	131	129	125	157	144	133	131	128	159	146	136	134	131	162	148	138	136	135	164	151	140	139	139
1200	MBh†	42.40	38.68	35.97	35.34	34.65	40.49	36.90	34.30	33.74	33.35	38.44	35.00	32.52	32.07	31.93	36.24	32.97	30.61	30.45	30.41	33.91	30.79	28.56	28.80	28.76
	S/T†	0.55	0.75	0.77	0.97	1.00	0.55	0.76	0.79	0.99	1.00	0.56	0.78	0.81	0.99	1.00	0.57	0.80	0.83	1.00	1.00	0.59	0.83	0.86	1.00	1.00
	AMPS*	9.91	9.82	9.77	9.76	9.75	11.06	10.94	10.87	10.86	10.85	12.30	12.17	12.10	12.09	12.08	13.69	13.56	13.49	13.48	13.48	15.27	15.16	15.09	15.09	15.09
	HIPR	274	271	269	268	268	317	313	311	310	310	364	360	357	356	356	416	411	407	407	407	471	466	463	463	463
	LO PR	158	145	135	133	130	160	147	137	135	133	163	149	139	137	137	165	151	141	141	141	167	153	143	145	144
1350	MBh†	43.03	39.27	36.55	36.05	35.84	41.06	37.43	34.82	34.51	34.46	38.93	35.47	32.98	33.01	32.97	36.68	33.38	31.02	31.41	31.37	34.27	31.16	28.92	29.67	29.63
	S/T†	0.56	0.78	0.80	1.01	1.00	0.57	0.80	0.82	1.00	1.00	0.58	0.82	0.84	1.00	1.00	0.60	0.84	0.87	1.00	1.00	0.61	0.87	0.90	1.00	1.00
	AMPS*	10.05	9.96	9.90	9.90	9.89	11.20	11.08	11.01	11.00	11.00	12.44	12.32	12.24	12.24	12.24	13.83	13.71	13.63	13.64	13.64	15.42	15.29	15.23	15.25	15.25
	HIPR	275	271	269	269	269	318	314	311	311	311	365	361	357	357	357	416	412	408	409	409	472	467	463	465	465
	LO PR	161	148	137	136	135	163	149	139	138	138	165	151	141	142	141	167	153	143	145	145	170	156	145	149	149

HEATING		36 Size Outdoor With FXM4X36*** Indoor Heating																											
		Outdoor Ambient Temperature - Degrees F, Dry Bulb										Outdoor Ambient Temperature - Degrees F, Dry Bulb																	
		-3					7					17					47					57					67		
CFM	65	70	75	65	70	75	65	70	75	65	70	75	65	70	75	65	70	75	65	70	75	65	70	75	65	70	75		
1050	MBh†	11.44	10.73	9.98	15.33	14.64	13.92	19.61	18.94	18.23	24.41	23.71	22.97	29.99	29.52	28.97	35.11	34.56	33.99	40.74	40.20	39.54	46.35	45.76	45.14	41.10	41.10	41.10	
	T/R	10.50	9.80	9.10	14.00	13.40	12.70	17.90	17.30	16.60	22.30	21.60	20.90	27.40	26.90	26.40	32.10	31.50	31.00	37.30	36.70	36.00	42.40	41.80	41.10	41.10	41.10	41.10	
	AMPS*	8.57	8.99	9.42	8.96	9.38	9.83	9.36	9.80	10.26	9.82	10.27	10.73	10.40	10.91	11.43	10.94	11.45	12.00	11.52	12.09	12.70	12.07	12.64	13.23	13.23	13.23	13.23	
	HIPR	219	234	249	233	248	264	249	265	281	267	284	301	291	310	328	315	333	353	339	360	381	361	382	403	403	403		
	LO PR	37	37	38	48	48	49	60	61	61	61	74	74	75	90	90	90	107	108	108	126	127	128	144	145	146	146		
1200	MBh†	11.66	10.95	10.20	15.60	14.91	14.18	19.93	19.26	18.55	24.85	24.10	23.37	30.35	29.87	29.35	35.57	35.00	34.43	41.14	40.60	40.10	46.50	45.95	45.39	45.39	45.39		
	T/R	9.30	8.70	8.10	12.50	11.90	11.30	16.00	15.40	14.80	19.90	19.30	18.60	24.30	23.90	23.40	28.50	28.00	27.40	32.90	32.40	32.00	37.20	36.70	36.20	36.20	36.20		
	AMPS*	8.62	9.04	9.47	8.97	9.40	9.84	9.33	9.77	10.23	9.75	10.20	10.66	10.26	10.76	11.28	10.74	11.25	11.78	11.19	11.74	12.33	11.71	12.26	12.84	12.84	12.84		
	HIPR	216	231	246	229	244	260	243	259	276	260	276	294	282	300	319	303	321	341	322	343	364	343	363	384	384	384		
	LO PR	37	37	38	48	48	49	60	60	61	61	74	74	75	89	90	90	107	107	108	125	126	127	142	143	144	144		
1350	MBh†	11.86	11.15	10.39	15.83	15.15	14.41	20.21	19.53	18.82	25.78	24.44	23.70	30.66	30.17	29.66	35.94	35.37	34.80	41.32	40.83	40.32	46.51	46.01	45.49	45.49			
	T/R	8.40	7.90	7.40	11.30	10.80	10.20	14.40	13.90	13.30	18.30	17.40	16.80	21.80	21.40	21.00	25.60	25.10	24.60	29.40	29.00	28.60	33.10	32.70	32.20	32.20			
	AMPS*	8.68	9.10	9.54	9.00	9.43	9.88	9.33	9.78	10.24	9.79	10.16	10.63	10.18	10.67	11.18	10.62	11.12	11.65	10.99	11.52	12.09	11.45	12.00	12.57	12.57			
	HIPR	214	229	244	226	241	257	239	255	272	256	271	288	274	292	311	294	312	332	310	330	351	329	349	370	370			
	LO PR	37	37	38	48	48	49	60	60	61	61	73	74	75	89	90	90	107	107	108	123	124	125	140	141	142	142		

COOLING		37 Size Outdoor With FXM4X36**A* Indoor Cooling																								
		Outdoor Ambient Temperature - Degrees F, Dry Bulb																								
		75					85					95					105		115							
CFM		72	67	63††	62	57	72	67	63††	62	57	72	67	63††	62	57	72	67	63††	62	57					
1050	MBh†	42.31	38.38	35.52	34.85	33.47	40.50	36.70	33.94	33.32	32.27	38.57	34.92	32.27	31.70	30.99	36.51	33.01	30.46	29.98	29.60	34.30	30.95	28.53	28.19	28.09
	ST†	0.51	0.68	0.71	0.89	1.00	0.51	0.70	0.72	0.91	1.00	0.52	0.71	0.74	0.93	1.00	0.53	0.73	0.76	0.95	1.00	0.54	0.75	0.78	1.00	1.00
	AMPS*	9.63	9.54	9.49	9.48	9.45	10.71	10.60	10.53	10.52	10.50	11.87	11.76	11.68	11.67	11.65	13.18	13.06	12.98	12.97	12.96	14.67	14.55	14.48	14.47	14.47
	HI PR	258	256	253	253	252	300	297	294	294	293	346	342	339	339	338	396	392	389	388	387	451	446	442	442	442
	LO PR	152	139	129	127	123	155	141	131	130	126	157	144	134	132	129	159	146	136	134	133	162	148	138	137	137
1200	MBh†	43.22	39.21	36.32	35.71	34.94	41.31	37.46	34.66	34.14	33.66	39.30	35.60	32.91	32.50	32.29	37.16	33.62	31.05	30.86	30.82	34.86	31.48	29.03	29.25	29.21
	ST†	0.52	0.71	0.74	0.93	1.00	0.53	0.73	0.75	0.95	1.00	0.54	0.74	0.77	0.97	1.00	0.55	0.76	0.79	1.00	1.00	0.56	0.79	0.82	1.00	1.00
	AMPS*	9.79	9.69	9.63	9.62	9.61	10.86	10.75	10.67	10.66	10.65	12.03	11.91	11.82	11.81	11.81	13.33	13.21	13.13	13.12	13.12	14.81	14.69	14.62	14.63	14.63
	HI PR	259	256	254	254	253	301	298	295	295	294	347	343	340	339	339	397	393	389	389	389	452	447	443	444	444
	LO PR	156	143	133	131	128	158	145	134	133	131	160	147	136	135	135	162	149	139	138	138	165	151	141	141	142
1350	MBh†	43.89	39.85	36.92	36.47	36.18	41.93	38.03	35.22	34.89	34.82	39.86	36.12	33.42	33.38	33.38	37.65	34.07	31.48	31.87	31.82	35.29	31.88	29.42	30.17	30.13
	ST†	0.54	0.74	0.77	0.96	1.00	0.54	0.76	0.78	1.00	1.00	0.55	0.78	0.80	1.00	1.00	0.57	0.80	0.83	1.00	1.00	0.58	0.83	0.85	1.00	1.00
	AMPS*	9.93	9.83	9.77	9.76	9.75	11.01	10.89	10.81	10.81	10.81	12.18	12.05	11.96	11.97	11.97	13.48	13.35	13.26	13.28	13.28	14.96	14.83	14.76	14.78	14.78
	HI PR	260	257	255	254	254	302	298	296	296	296	348	344	341	341	341	398	394	390	391	391	453	448	444	445	445
	LO PR	158	145	135	134	133	160	147	137	136	136	162	149	139	139	139	165	151	141	143	143	167	153	143	147	146

HEATING		37 Size Outdoor With FXM4X36**A* Indoor Heating																							
		Outdoor Ambient Temperature - Degrees F, Dry Bulb																							
		- 3					17					37					47		57		67				
CFM		65	70	75	65	70	75	65	70	75	65	70	75	65	70	75	65	70	75	65	70	75			
1050	MBh†	11.79	11.03	10.22	15.82	15.09	14.31	20.29	19.57	18.81	25.91	24.68	23.79	30.74	30.19	29.65	36.13	35.49	34.86	42.15	41.43	40.73	48.98	48.14	47.31
	T/R	10.30	9.70	8.90	13.90	13.20	12.50	17.80	17.10	16.40	22.70	21.60	20.80	27.00	26.40	25.90	31.70	31.10	30.40	37.00	36.30	35.60	43.00	42.20	41.30
	AMPS*	9.23	9.66	10.11	9.64	10.09	10.55	10.08	10.54	11.01	10.65	11.05	11.53	11.15	11.67	12.22	11.74	12.28	12.84	12.47	13.01	13.59	13.35	13.91	14.50
	HI PR	220	234	249	233	249	264	249	265	282	271	285	302	291	310	329	316	334	354	344	363	383	376	396	416
	LO PR	35	35	35	46	46	46	58	58	59	72	72	72	87	88	88	105	105	105	124	124	125	145	145	146
1200	MBh†	11.99	11.27	10.46	16.09	15.39	14.60	20.62	19.92	19.16	26.26	25.70	24.24	31.15	30.59	30.03	36.64	36.00	35.35	42.77	42.06	41.33	49.85	48.95	48.09
	T/R	9.20	8.60	8.00	12.40	11.80	11.20	15.80	15.30	14.60	20.20	19.70	18.50	23.90	23.40	23.00	28.10	27.60	27.00	32.80	32.20	31.60	38.30	37.50	36.80
	AMPS*	9.27	9.71	10.17	9.65	10.10	10.57	10.04	10.51	10.98	10.55	11.04	11.44	10.99	11.51	12.05	11.53	12.07	12.62	12.21	12.74	13.29	13.03	13.57	14.15
	HI PR	216	231	247	229	244	260	243	259	276	263	280	295	281	300	319	303	322	342	330	349	368	360	379	399
	LO PR	35	35	35	46	46	46	58	58	58	72	72	72	87	87	88	104	105	105	123	124	124	145	145	145
1350	MBh†	12.21	11.49	10.68	16.34	15.63	14.86	20.93	20.22	19.46	26.54	26.00	24.65	31.49	30.94	30.37	37.06	36.41	35.76	43.31	42.56	41.83	50.54	49.62	48.72
	T/R	8.30	7.80	7.30	11.20	10.60	10.10	14.30	13.80	13.20	18.10	17.70	16.70	21.50	21.10	20.60	25.30	24.80	24.30	29.60	29.00	28.40	34.50	33.80	33.10
	AMPS*	9.33	9.78	10.24	9.68	10.13	10.61	10.04	10.51	10.99	10.50	10.99	11.41	10.91	11.42	11.96	11.40	11.93	12.48	12.04	12.57	13.11	12.82	13.35	13.92
	HI PR	214	229	245	225	241	257	239	255	272	256	274	289	274	292	311	294	313	332	319	338	357	347	366	386
	LO PR	35	35	35	46	46	46	58	58	58	72	72	72	87	87	88	104	105	105	123	124	124	145	145	145

COOLING		42 Size Outdoor With FXM4X42*** Indoor Cooling																								
		Outdoor Ambient Temperature - Degrees F, Dry Bulb										Wet Bulb														
		75					85					95					105					115				
CFM		72	67	63††	62	57	72	67	63††	62	57	72	67	63††	62	57	72	67	63††	62	57	72	67	63††	62	57
1225	MBh†	50.43	45.65	42.23	41.36	39.50	48.01	43.47	40.23	39.42	38.01	45.51	41.22	38.16	37.42	36.44	42.89	38.86	35.97	35.33	34.77	40.16	36.38	33.68	33.17	32.98
	S/T‡	0.51	0.69	0.71	0.89	1.00	0.52	0.70	0.73	0.91	1.00	0.52	0.71	0.74	0.93	1.00	0.53	0.73	0.76	0.96	1.00	0.54	0.75	0.78	0.99	1.00
	AMPS*	10.72	11.27	11.60	11.67	11.81	12.45	12.85	13.09	13.13	13.21	14.19	14.48	14.63	14.65	14.68	16.02	16.20	16.28	16.28	16.29	17.96	18.05	18.07	18.07	18.07
	HI PR	270	266	263	263	261	312	308	304	304	302	358	353	350	349	348	408	403	399	398	398	463	457	453	453	452
	LO PR	151	139	129	127	121	154	141	131	129	125	156	143	133	131	128	159	146	136	134	132	162	148	138	137	136
1400	MBh†	51.53	46.66	43.19	42.36	41.23	48.98	44.38	41.08	40.35	39.62	46.35	42.00	38.90	38.28	37.93	43.62	39.54	36.62	36.20	36.14	40.76	36.95	34.22	34.27	34.22
	S/T‡	0.52	0.71	0.74	0.93	1.00	0.53	0.73	0.76	0.95	1.00	0.54	0.75	0.77	0.98	1.00	0.55	0.77	0.79	1.00	1.00	0.56	0.79	0.82	1.00	1.00
	AMPS*	10.74	11.32	11.69	11.75	11.85	12.51	12.95	13.21	13.25	13.29	14.29	14.61	14.78	14.80	14.81	16.15	16.35	16.44	16.45	16.45	18.12	18.23	18.26	18.26	18.26
	HI PR	271	267	264	264	263	313	309	305	305	304	359	354	351	350	350	409	404	400	400	400	464	459	454	455	455
	LO PR	155	142	132	130	127	157	144	134	132	130	160	146	136	135	134	162	149	138	138	137	165	151	141	141	141
1575	MBh†	52.37	47.45	43.93	43.23	42.69	49.72	45.05	41.73	41.18	40.98	47.00	42.59	39.46	39.23	39.18	44.15	40.05	37.10	37.32	37.28	41.21	37.37	34.64	35.29	35.25
	S/T‡	0.54	0.74	0.77	0.97	1.00	0.55	0.76	0.78	0.99	1.00	0.56	0.78	0.81	1.00	1.00	0.57	0.80	0.83	1.00	1.00	0.58	0.83	0.86	1.00	1.00
	AMPS*	10.79	11.40	11.79	11.84	11.89	12.59	13.06	13.33	13.36	13.38	14.41	14.75	14.93	14.93	14.94	16.29	16.51	16.62	16.60	16.61	18.27	18.40	18.44	18.43	18.43
	HI PR	272	268	265	264	264	314	310	306	306	306	360	355	351	351	351	410	405	401	401	401	465	459	455	456	456
	LO PR	158	145	135	133	132	160	147	137	135	135	162	149	139	138	138	165	151	141	142	142	167	153	143	144	146

HEATING		42 Size Outdoor With FXM4X42*** Indoor Heating																																					
		Outdoor Ambient Temperature - Degrees F, Dry Bulb										Wet Bulb																											
		-3					7					17					27					37					47					57					67		
CFM		65	70	75	65	70	75	65	70	75	65	70	75	65	70	75	65	70	75	65	70	75	65	70	75	65	70	75											
1225	MBh†	15.59	14.91	14.21	20.20	19.56	18.88	25.92	24.56	23.85	30.84	30.36	29.87	36.17	35.61	35.07	42.10	41.46	40.82	48.79	48.00	47.26	56.67	55.78	54.86														
	T/R	12.40	11.80	11.20	16.10	15.50	14.90	20.60	19.50	18.90	24.50	24.10	23.60	28.70	28.20	27.70	33.50	32.90	32.30	38.80	38.10	37.40	45.00	44.20	43.40														
	AMPS*	9.95	10.53	11.15	10.66	11.20	11.77	11.54	11.95	12.48	12.31	12.83	13.38	13.03	13.56	14.13	13.73	14.30	14.90	14.45	15.06	15.70	15.00	15.71	16.47														
	HI PR	228	243	259	243	259	275	263	277	294	281	299	318	302	321	340	327	346	366	358	377	398	389	410	432														
	LO PR	35	36	36	46	46	47	58	58	59	72	72	72	87	88	88	105	105	105	123	124	125	145	146	146														
1400	MBh†	15.85	15.19	14.48	20.53	19.88	19.21	26.26	24.93	24.24	31.19	30.71	30.24	36.63	36.05	35.49	42.66	42.00	41.35	49.49	48.69	47.91	57.34	56.54	55.73														
	T/R	11.00	10.50	10.00	14.30	13.80	13.30	18.30	17.30	16.80	21.70	21.30	20.90	25.50	25.00	24.60	29.70	29.10	28.60	34.40	33.80	33.20	39.90	39.20	38.60														
	AMPS*	9.99	10.58	11.20	10.68	11.22	11.79	11.53	11.93	12.46	12.25	12.76	13.31	12.93	13.45	14.01	13.55	14.12	14.71	14.18	14.80	15.43	14.59	15.28	16.00														
	HI PR	225	240	256	238	254	271	256	270	287	272	290	309	292	310	330	315	334	354	344	363	383	371	392	413														
	LO PR	35	35	36	46	46	46	58	58	59	72	72	72	87	88	88	104	105	105	123	124	124	144	145	145														
1575	MBh†	16.10	15.44	14.73	20.82	20.17	19.49	26.55	25.36	24.58	31.50	31.04	30.53	37.01	36.43	35.86	43.12	42.45	41.79	50.13	49.26	48.46	57.72	56.99	56.22														
	T/R	10.00	9.50	9.10	12.90	12.40	12.00	16.40	15.60	15.10	19.50	19.10	18.80	22.90	22.50	22.10	26.60	26.20	25.70	31.00	30.40	29.80	35.70	35.20	34.60														
	AMPS*	10.06	10.66	11.28	10.73	11.27	11.84	11.55	11.97	12.49	12.24	12.76	13.29	12.88	13.41	13.96	13.46	14.02	14.61	13.96	14.64	15.27	14.33	15.01	15.72														
	HI PR	222	237	253	234	250	267	250	265	282	266	284	302	284	302	321	306	325	344	331	352	372	358	378	399														
	LO PR	35	35	36	46	46	46	58	58	59	72	72	72	87	87	88	104	104	105	123	123	124	143	144	145														

COOLING		48 Size Outdoor With FXM4X48**** Indoor Cooling																				
		Outdoor Ambient Temperature - Degrees F, Dry Bulb										Entering Indoor Temperature - Degrees F, Wet Bulb										
		75	80	85	90	95	100	105	110	115	120	62	67	72	77	82	87	92	97	102	107	
1400	CFM	72	67	63††	62	57	72	67	63††	62	57	72	67	63††	62	57	72	67	63††	62	57	
	MBh†	56.41	51.26	47.52	46.57	44.64	53.61	48.73	45.19	44.30	42.89	50.78	46.17	42.82	42.03	41.08	47.89	43.54	40.39	39.68	39.20	
	S/T†	0.52	0.70	0.72	0.91	1.00	0.52	0.71	0.74	0.93	1.00	0.53	0.73	0.75	0.95	1.00	0.54	0.75	0.77	0.98	1.00	1.00
	AMPS*	12.48	12.61	12.70	12.71	12.75	14.34	14.38	14.38	14.37	14.37	16.18	16.13	16.07	16.05	16.03	18.07	17.96	17.85	17.83	17.81	20.09
	HI PR	273	269	266	265	264	316	311	308	307	305	362	357	353	353	351	413	407	403	402	402	467
1600	LO PR	154	140	131	128	123	156	143	133	131	127	159	145	135	133	130	161	148	137	135	134	164
	MBh†	57.57	52.36	48.57	47.68	46.58	54.62	49.68	46.11	45.32	44.69	51.67	47.00	43.64	42.99	42.74	48.64	44.26	41.09	40.78	40.72	45.53
	S/T†	0.53	0.73	0.75	0.95	1.00	0.54	0.74	0.77	0.97	1.00	0.55	0.76	0.79	1.00	1.00	0.56	0.78	0.81	1.00	1.00	0.57
	AMPS*	12.64	12.79	12.88	12.89	12.91	14.53	14.58	14.58	14.58	14.58	16.40	16.35	16.29	16.28	16.28	18.30	18.19	18.09	18.08	18.08	20.33
	HI PR	274	270	267	266	265	317	312	309	308	307	363	358	354	354	354	414	408	404	404	404	468
1800	LO PR	157	144	134	132	129	160	146	136	134	132	162	148	138	136	136	164	151	140	140	139	167
	MBh†	58.45	53.17	49.37	48.62	48.21	55.39	50.40	46.81	46.27	46.19	52.32	47.62	44.24	44.18	44.12	49.20	44.78	41.61	42.04	41.99	46.00
	S/T†	0.55	0.76	0.78	0.99	1.00	0.56	0.78	0.80	1.00	1.00	0.57	0.80	0.82	1.00	1.00	0.58	0.82	0.85	1.00	1.00	0.60
	AMPS*	12.81	12.97	13.06	13.07	13.08	14.73	14.77	14.79	14.79	14.79	16.61	16.56	16.51	16.51	16.51	18.52	18.41	18.32	18.33	18.33	20.55
	HI PR	275	271	268	267	267	318	313	310	309	309	364	359	355	355	355	415	409	405	406	406	469
LO PR	160	147	136	135	134	162	149	138	137	137	164	151	140	141	141	167	153	142	144	144	169	

HEATING		48 Size Outdoor With FXM4X48**** Indoor Heating																			
		Outdoor Ambient Temperature - Degrees F, Dry Bulb										Entering Indoor Temperature - Degrees F, Dry Bulb									
		-3	7	17	27	37	47	57	67	75	85	65	70	75	80	85	90	95	100	105	110
1400	CFM	65	70	75	65	70	75	65	70	75	65	70	75	65	70	75	65	70	75	65	70
	MBh†	16.57	15.87	15.12	12.81	21.11	20.36	27.41	26.67	25.90	34.27	33.71	32.01	40.13	39.54	38.99	46.61	45.93	45.26	54.13	53.21
	T/R	11.40	10.90	10.30	15.00	14.50	13.90	18.80	18.30	17.70	23.60	23.10	21.90	27.60	27.10	26.70	32.10	31.50	31.00	37.20	36.50
	AMPS*	11.66	12.14	12.66	12.18	12.67	13.20	12.74	13.25	13.80	13.50	14.06	14.48	14.12	14.73	15.38	14.81	15.47	16.15	15.55	16.31
	HI PR	222	237	253	236	252	268	252	268	285	273	290	305	292	310	330	314	333	353	338	359
1600	LO PR	35	35	35	45	45	45	57	57	57	70	70	71	85	86	86	102	102	103	121	121
	MBh†	16.86	16.17	15.41	22.16	21.47	20.72	27.81	27.09	26.32	34.67	34.13	32.64	40.59	40.01	39.43	47.19	46.50	45.81	54.95	54.10
	T/R	10.10	9.70	9.20	13.30	12.90	12.40	16.70	16.30	15.80	20.90	20.50	19.50	24.40	24.00	23.60	28.40	27.90	27.40	33.10	32.50
	AMPS*	11.78	12.25	12.77	12.25	12.74	13.26	12.76	13.27	13.82	13.45	14.01	14.46	14.00	14.61	15.25	14.62	15.27	15.95	15.17	15.90
	HI PR	219	234	250	231	247	264	246	262	280	264	282	298	282	300	320	302	321	341	322	342
1800	LO PR	35	35	35	45	45	45	57	57	57	70	70	71	85	85	86	102	102	103	120	121
	MBh†	17.13	16.43	15.68	22.46	21.77	21.03	28.18	27.45	26.68	34.99	34.48	33.89	40.98	40.41	39.81	47.67	46.98	46.28	55.35	54.64
	T/R	9.20	8.80	8.30	12.00	11.60	11.20	15.10	14.70	14.20	18.70	18.40	18.00	21.90	21.60	21.20	25.50	25.10	24.60	29.60	29.20
	AMPS*	11.91	12.38	12.90	12.35	12.83	13.36	12.82	13.34	13.88	13.46	14.03	14.60	13.95	14.57	15.20	14.82	15.17	15.84	14.97	15.68
	HI PR	216	232	248	228	244	261	241	258	275	258	276	294	274	293	312	294	312	332	311	331
LO PR	35	35	35	45	45	45	57	57	57	70	70	70	85	85	86	101	102	102	120	120	

COOLING		60 Size Outdoor With FXM4X60*** Indoor Cooling																			
		Outdoor Ambient Temperature - Degrees F, Dry Bulb																			
		75					85					95					105		115		
CFM	72	67	63††	62	57	72	67	63††	62	57	72	67	63††	62	57	72	67	63††	62	57	
1750	MBh†	69.17	63.19	58.86	57.71	55.78	65.83	60.19	56.08	55.03	53.67	62.32	57.00	53.14	52.20	51.40	58.60	53.63	50.02	49.23	48.93
	S/T†	0.52	0.70	0.73	0.91	1.00	0.53	0.72	0.74	0.93	1.00	0.53	0.73	0.76	0.96	1.00	0.54	0.75	0.78	0.98	1.00
	AMPS*	16.56	16.26	16.05	16.00	15.92	18.25	17.95	17.72	17.68	17.61	20.14	19.83	19.61	19.56	19.52	22.27	21.96	21.74	21.71	21.69
	HIPR	285	280	276	275	273	328	323	319	318	316	375	369	365	364	363	426	420	415	415	414
	LO PR	156	143	132	130	126	159	145	134	132	129	161	147	136	134	132	163	149	139	137	136
2000	MBh†	70.36	64.35	59.99	58.97	58.06	66.90	61.20	57.09	56.19	55.76	63.21	57.88	54.01	53.39	53.31	59.35	54.36	50.76	50.73	50.67
	S/T†	0.53	0.73	0.76	0.96	1.00	0.54	0.75	0.77	0.98	1.00	0.55	0.77	0.79	1.00	1.00	0.57	0.79	0.82	1.00	1.00
	AMPS*	16.91	16.60	16.38	16.34	16.30	18.61	18.29	18.06	18.02	18.00	20.48	20.17	19.94	19.92	19.91	22.60	22.30	22.07	22.08	22.08
	HIPR	286	281	277	276	276	330	324	320	319	319	377	371	366	366	366	427	421	417	417	417
	LO PR	160	146	136	134	132	162	148	137	136	135	164	150	139	138	138	166	152	142	142	142
2250	MBh†	71.26	65.22	60.84	60.05	59.92	67.65	61.95	57.83	57.48	63.86	58.50	54.65	54.95	54.88	59.89	54.89	51.31	52.14	52.08	55.65
	S/T†	0.55	0.77	0.79	1.00	1.00	0.56	0.79	0.81	1.00	1.00	0.57	0.81	0.83	1.00	1.00	0.59	0.84	0.86	1.00	1.00
	AMPS*	17.25	16.93	16.71	16.68	16.68	18.94	18.62	18.39	18.38	18.38	20.81	20.49	20.26	20.29	20.29	22.93	22.62	22.39	22.45	22.45
	HIPR	287	282	278	278	277	331	325	321	321	321	378	372	367	368	368	428	422	418	419	419
	LO PR	163	149	138	137	137	165	151	140	140	140	167	153	142	143	143	169	155	144	147	147

HEATING		60 Size Outdoor With FXM4X60*** Indoor Heating																			
		Outdoor Ambient Temperature - Degrees F, Dry Bulb																			
		-3					7					17					47		57		67
CFM	65	70	75	80	85	65	70	75	80	85	65	70	75	80	85	65	70	75	80	85	
1750	MBh†	20.52	19.47	18.37	26.79	25.79	24.74	33.46	32.51	31.51	40.87	39.83	38.79	49.38	48.67	47.98	57.35	56.50	55.67	66.82	65.73
	T/R	10.90	10.30	9.70	14.20	13.70	13.10	17.80	17.20	16.70	21.70	21.10	20.50	26.20	25.80	25.40	30.50	30.00	29.50	35.50	34.90
	AMPS*	14.23	14.82	15.44	14.84	15.47	16.14	15.46	16.13	16.84	16.14	16.85	17.59	17.03	17.81	18.66	17.85	18.66	19.53	18.82	19.71
	HIPR	219	234	250	232	248	264	246	263	280	263	280	297	284	302	321	304	323	342	327	347
	LO PR	34	34	35	44	44	45	56	56	56	69	69	69	83	83	84	99	100	100	118	119
2000	MBh†	20.93	19.88	18.79	27.26	26.25	25.21	34.00	33.04	32.04	41.73	40.47	39.41	49.94	49.24	48.57	58.09	57.22	56.38	67.96	66.73
	T/R	9.70	9.20	8.70	12.70	12.20	11.70	15.80	15.30	14.80	19.40	18.80	18.20	23.20	22.90	22.50	27.00	26.60	26.10	31.60	31.00
	AMPS*	14.40	14.99	15.62	14.96	15.59	16.26	15.51	16.19	16.90	16.15	16.84	17.57	16.92	17.71	18.53	17.66	18.47	19.32	18.45	19.33
	HIPR	216	232	247	228	244	260	241	257	274	256	273	290	274	293	312	293	311	331	312	332
	LO PR	34	34	34	44	44	45	56	56	56	68	69	69	83	83	83	99	99	100	118	119
2250	MBh†	21.30	20.25	19.15	27.68	26.67	25.62	34.47	33.51	32.51	43.09	41.03	39.96	50.46	49.75	49.02	58.71	57.83	56.97	68.69	67.70
	T/R	8.80	8.40	7.90	11.40	11.00	10.50	14.30	13.80	13.40	17.80	16.90	16.40	20.90	20.50	20.20	24.30	23.90	23.40	28.40	27.90
	AMPS*	14.60	15.19	15.82	15.12	15.75	16.42	15.62	16.30	17.01	16.33	16.89	17.62	16.91	17.69	18.49	17.59	18.38	19.22	18.26	19.10
	HIPR	214	229	245	225	241	257	236	253	270	253	267	285	267	285	304	284	303	322	301	320
	LO PR	34	34	34	44	44	45	55	56	56	68	69	69	83	83	83	99	99	100	118	118

NXH5 PARTS LIST										
KEY NO.	DESCRIPTION	FAST PARTS NO.	NXH518GKA100	NXH524GKA100	NXH530GKA100	NXH536GKA100	NXH537GKA100	NXH542GKA100	NXH548GKA100	NXH560GKA100
01	COMP ZP16K5E-PFV-130	ZP16K5EPFV130	1	-	-	-	-	-	-	-
01	COMP ZP21K5E-PFV-130	ZP21K5EPFV130	-	1	-	-	-	-	-	-
01	COMP ZP25K5E-PFV-130	ZP25K5EPFV130	-	-	1	-	-	-	-	-
01	COMP ZP31K5E-PFV-130	ZP31K5EPFV130	-	-	-	1	1	-	-	-
01	COMP ZP38K5E-PFV-130	ZP38K5EPFV130	-	-	-	-	-	1	-	-
01	COMP ZP42K5E-PFV-130	ZP42K5EPFV130	-	-	-	-	-	-	1	-
01	COMP ZP51K5E-PFV-130	ZP51K5EPFV130	-	-	-	-	-	-	-	1
02	MTR CND 1/230 1/12 800	1173716	1	1	1	-	-	-	-	-
02	MTR CND 1/230 1/5 810	1173660	-	-	-	1	1	1	-	-
02	MTR CND 1/230 1/4 825	1173665	-	-	-	-	-	-	1	1
03	FAN C 24" 3B 1/2" 15 INT	1173721	1	-	-	-	-	-	-	-
03	FAN C 26" 3B 1/2" 16 INT	1174940	-	1	1	-	-	-	-	-
03	FAN C 26" 3B 1/2" 21 INT	1173661	-	-	-	1	1	1	-	-
03	FAN C 26" 3B 1/2" 24 INT	1172716	-	-	-	-	-	-	1	1
04	CONTACTOR 1P 30A 24V W/SHUNT	1172472	1	1	1	1	1	1	1	-
04	CONTACTOR 1P 40A	1176763	-	-	-	-	-	-	-	1
05	CAP RN RD 370V 5+30	1172109	1	-	-	-	-	-	-	-
05	CAP RN RD 370V 5+40	1172147	-	1	1	-	-	-	-	-
05	CAP RN RD 370V 5+45	1172124	-	-	-	1	1	1	-	-
05	CAP RN RD 370V 7.5+70	1172295	-	-	-	-	-	-	1	1
06	COND COIL ASSY	1179380	1	-	-	-	-	-	-	-
06	COND COIL ASSY	1179381	-	1	-	-	-	-	-	-
06	COND COIL ASSY	1179382	-	-	1	-	-	-	-	-
06	COND COIL ASSY	1179383	-	-	-	1	-	-	-	-
06	COND COIL ASSY FORMED	1174931	-	-	-	-	1	-	-	-
06	COND COIL ASSY	1179384	-	-	-	-	-	1	1	-
06	COND COIL ASSY	1179385	-	-	-	-	-	-	-	1
07	VALVE SVC PARK SUC 10S-10S	1172725	1	1	-	-	-	-	-	-
07	VALVE SVC PARK SUC 12S-12S	1172726	-	-	1	1	1	-	-	-
07	VALVE SVC PARK SUC 14S-14S	1172727	-	-	-	-	-	1	1	1
08	VALVE SERVICE LIQUID	1173629	1	1	1	1	1	1	1	1
09	PLUG COMP WIRE (SM) 14GAX38"	1172729	1	-	-	-	-	-	-	-
09	PLUG COMP WIRE (SM) 52"	1174930	-	1	-	-	-	-	-	-
09	PLUG COMP WIRE (SM) 12GAX38"	1172730	-	-	1	-	-	-	-	-
09	PLUG COMP WIRE (SM) 12GAX44"	1172731	-	-	-	1	1	1	1	-
09	PLUG COMP WIRE (SM) 10GAX54"	1172732	-	-	-	-	-	-	-	1
10	GROMMET COMPRESSOR 1.62"DIA	1171270	4	4	4	4	4	4	4	4
11	BOLT SHLDR COMP. MTG,	1173630	4	4	4	4	4	4	4	4
12	VALVE REV W/COIL 24V	1173715	1	1	-	-	-	-	-	-
12	VALVE REV W/COIL 24V	1175621	-	-	-	-	1	-	-	-
12	VALVE REVERSING	1175621	-	-	1	1	-	-	-	-
12	VALVE REVERSING	1175622	-	-	-	-	-	1	1	1
13	COIL REV VLV 24V	1172574	1	1	1	1	1	1	1	1
14	HARNESS ASSY 52" RVS PLUG	1179387	1	1	1	1	1	1	1	1
15	ACCUMULATOR	1172312	1	-	-	-	-	-	-	-
15	ACCUMULATOR 174 3/4 5" DIA	1174937	-	1	-	-	-	-	-	-
15	ACCUMULATOR	1176606	-	-	1	-	-	-	-	-
15	ACCUMULATOR	1174703	-	-	-	1	1	-	-	-
15	ACCUMULATOR	1172122	-	-	-	-	-	1	-	-

- continued on next page -



NXH5 PARTS LIST (continued)										
KEY NO.	DESCRIPTION	FAST PARTS NO.	NXH518GKA100	NXH524GKA100	NXH530GKA100	NXH536GKA100	NXH537GKA100	NXH542GKA100	NXH548GKA100	NXH560GKA100
15	ACCUMULATOR	1172313	-	-	-	-	-	-	-	1
16	CAPILLARY ASSY FORMED	1174096	1	1	1	1	1	1	1	1
17	PRESSURE SWITCH LOW	1176661	1	1	1	1	1	1	1	1
18	PISTON CHATLEFF .042	1173634	1	-	-	-	-	-	-	-
18	PISTON CHATLEFF .046	1173650	-	1	-	-	-	-	-	-
18	PISTON .052	1174060	-	-	1	-	-	-	-	-
18	PISTON .059	1173871	-	-	-	-	1	-	-	-
18	PISTON CHATLEFF .061	1173663	-	-	-	1	-	1	-	-
18	PISTON CHATLEFF .067	1173867	-	-	-	-	-	-	1	-
18	PISTON .076	1173673	-	-	-	-	-	-	-	1
19	SWITCH PRESSURE HIGH	1174695	1	1	1	1	1	1	1	1
20	DISTRIBUTOR	1172020	1	-	-	-	-	-	-	-
20	DISTRIBUTOR	1172021	-	1	1	-	-	-	-	-
20	DISTRIBUTOR	1172022	-	-	-	1	1	-	-	-
20	DISTRIBUTOR	1173998	-	-	-	-	-	1	1	-
20	DISTRIBUTOR	1174018	-	-	-	-	-	-	-	1
22	SENSOR DEFROST O65 C32	1173637	1	1	1	1	1	1	1	1
23	MUFFLER	1173668	1	1	1	1	1	1	1	1
24	FILTER DRIER ASSY	1173991	1	1	1	1	1	1	1	-
24	FILTER DRIER ASSY	1174010	-	-	-	-	-	-	-	1
26	DEFROST CONTROL BOARD	1173636	1	1	1	1	1	1	1	1
28	CAP FLARE	1172410	1	1	1	1	1	1	1	1
29	GROMMET ACCUMULATOR CUSHION	1172806	1	1	1	1	1	1	1	1
30	CLIP ACCUM	1173640	1	1	1	1	1	1	1	1
31	RETAINER PISTON	1173641	1	1	1	1	1	1	1	1
32	RACEWAY	1171428	1	-	-	-	-	-	-	-
32	RACEWAY	1175919	-	1	1	1	1	1	1	1
33	LUG GROUND	1172300	1	1	1	1	1	1	1	1
34	HARNESS ASSY	1174744	1	1	1	1	1	1	1	1
35	HTR CC WP 40W240V TCH-245	1173944	-	-	-	-	-	-	-	1
35	HTR CC WP 40W240V TCH-268	1174709	-	-	-	-	1	-	-	-
36	SWITCH TEMP DISC O85 C65	1173669	-	-	-	-	1	-	-	1
A	TOP COVER ASY	1178565	-	1	1	1	1	1	1	1
A	TOP COVER ASY	1178643	1	-	-	-	-	-	-	-
B	NUT CAP HEX	1172740	4	4	4	4	4	4	4	4
C	GRILLE INLET	1178774	1	-	-	-	-	-	-	-
C	GRILLE INLET	1178912	-	1	1	-	-	-	-	-
C	GRILLE INLET	1178790	-	-	-	1	1	-	-	-
C	GRILLE INLET	1178803	-	-	-	-	-	1	1	-
C	GRILLE INLET	1178791	-	-	-	-	-	-	-	1
D	BOX CONTROL	1173643	1	1	1	1	1	1	1	1
E	KIT CONTROL BOX COVER	1179369	1	-	-	-	-	-	-	-
E	KIT CONTROL BOX COVER	1179370	-	1	-	-	-	-	-	-
E	KIT CONTROL BOX COVER	1179371	-	-	1	-	-	-	-	-
E	KIT CONTROL BOX COVER	1179372	-	-	-	1	-	-	-	-
E	KIT CONTROL BOX COVER	1179030	-	-	-	-	1	-	-	-
E	KIT CONTROL BOX COVER	1179373	-	-	-	-	-	1	-	-
E	KIT CONTROL BOX COVER	1179374	-	-	-	-	-	-	1	-

- continued on next page -

NXH5 PARTS LIST (continued)										
KEY NO.	DESCRIPTION	FAST PARTS NO.	NXH518GKA100	NXH524GKA100	NXH530GKA100	NXH536GKA100	NXH537GKA100	NXH542GKA100	NXH548GKA100	NXH560GKA100
E	KIT CONTROL BOX COVER	1179375	-	-	-	-	-	-	-	1
F	SVCE PNL ASSY	1178324	1	-	-	-	-	1	1	-
F	SVCE PNL ASSY	1178528	-	1	1	-	-	-	-	-
F	SVCE PNL ASSY	1178325	-	-	-	1	1	-	-	-
F	SVCE PNL ASSY	1178326	-	-	-	-	-	-	-	1
G	BASE PAN ASSY	1178308	1	-	-	-	-	-	-	-
G	BASE PAN ASSY	1178309	-	1	1	1	1	1	1	1
L	GUARD FAN	1179392	1	-	-	-	-	-	-	-
L	GUARD FAN	1178604	-	1	1	1	1	1	1	1
N	SUPPORT COIL	1174068	5	5	5	5	5	5	5	5
P	CLAMP CAPACITOR ROUND 2.0"D	1172734	1	1	1	1	1	1	-	-
P	CLAMP CAPACITOR ROUND 2.5"D	1172735	-	-	-	-	-	-	1	1
<b>PARTS NOT SHOWN</b>										
)	GROMMET	1171737	1	1	1	1	1	1	1	1
)	FILTER DRIER ASSY	1173991	-	-	-	-	-	-	-	1
)	DRIER FILTER SUCT LINE 8.0 CI	1174194	1	1	1	1	1	-	-	-
)	DRIER FILTER SUCT LINE 15.0 CI	1174193	-	-	-	-	-	1	1	1
)	KIT ADAPTER ASSY	1174192	1	1	1	1	1	1	1	1
)	CAP SERVICE KIT 11/16-20	1175650	1	1	1	1	1	1	1	1
)	CAP SERVICE KIT 15/16-20	1175651	1	1	1	1	1	-	-	-
)	CAP SERVICE KIT 1-1/16-20	1175652	-	-	-	-	-	1	1	1
)	PAINT TOUCH UP BALTIC GRY 1 PT	1178322	1	1	1	1	1	1	1	1
)	KIT PISTON TOOL BODY RESIZER	1175477	1	1	1	1	1	1	1	1
)	SCREW HEX HD 10AB X 3/8	1176782	14	14	14	14	14	14	14	14
)	SCREW HEX HEAD 12AB 5/8	1178281	4	4	4	4	4	4	4	4
)	SCREW HX HEAD 10AB 1/2	1178280	13	13	13	13	13	13	13	13

NOTE: This illustration is for reference only. Your unit may differ in appearance or may not include all components shown.

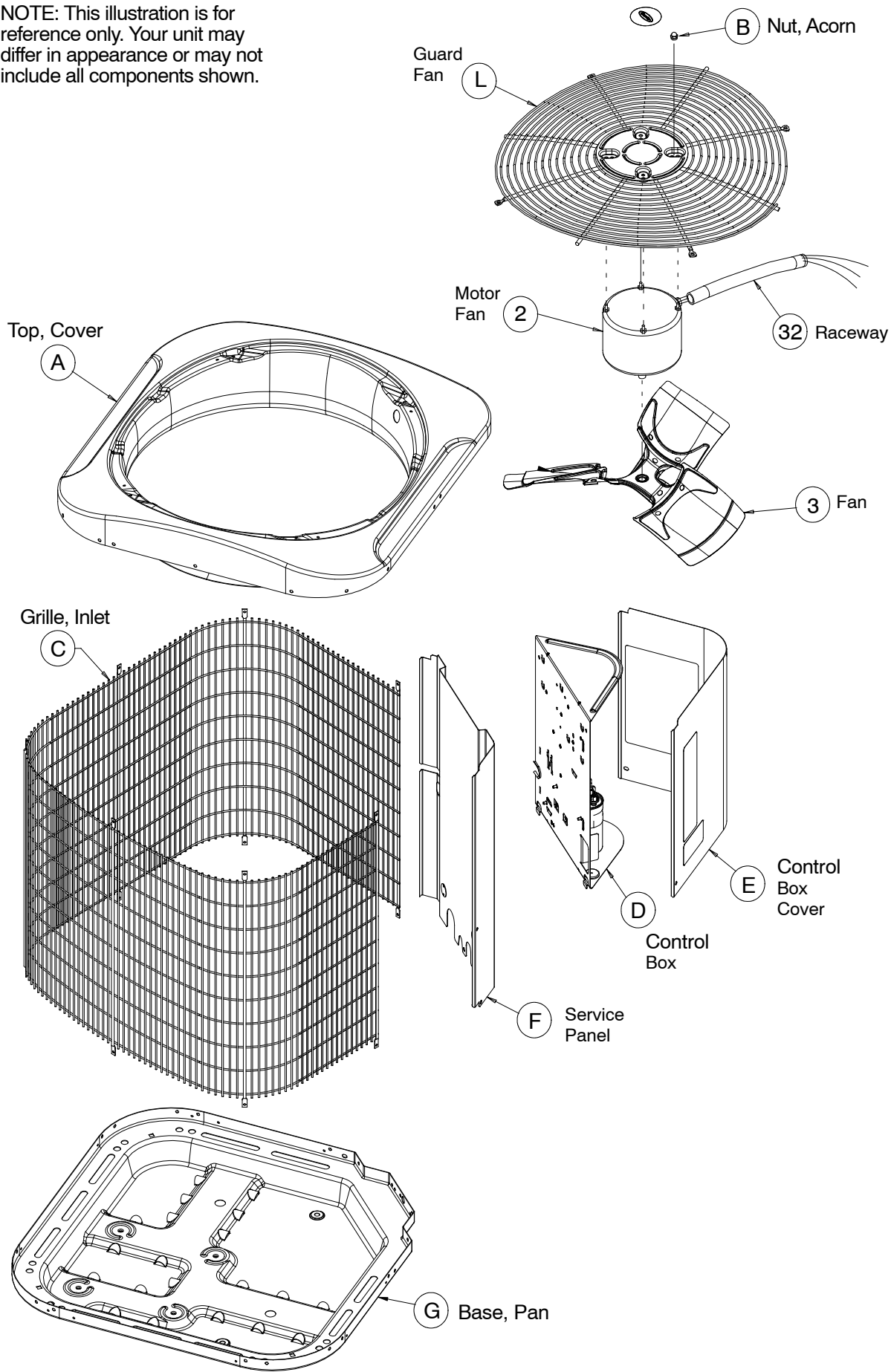

NOTE: This illustration is for reference only. Your unit may differ in appearance or may not include all components shown.

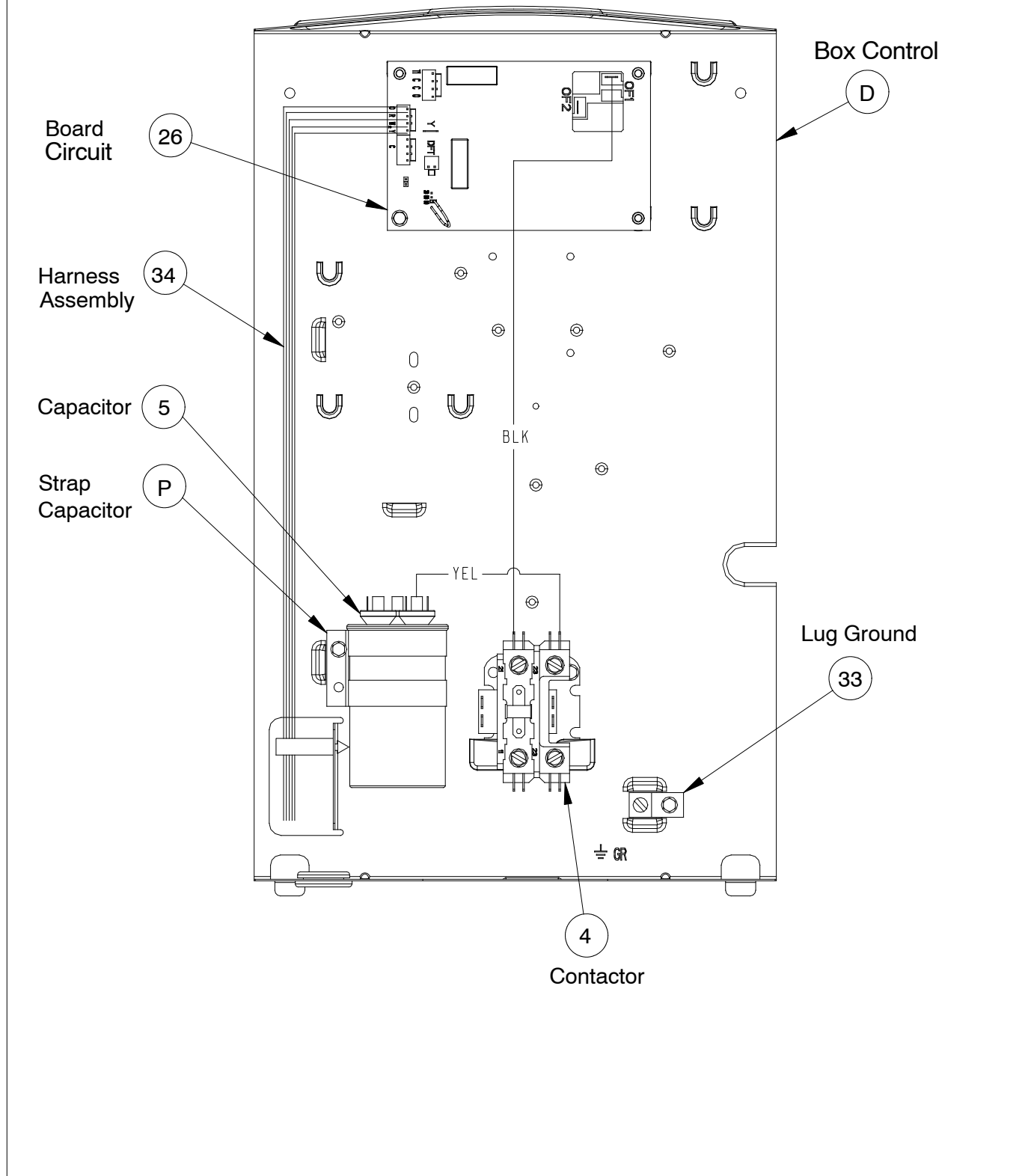

NOTE: This illustration is for reference only. Your unit may differ in appearance or may not include all components shown.

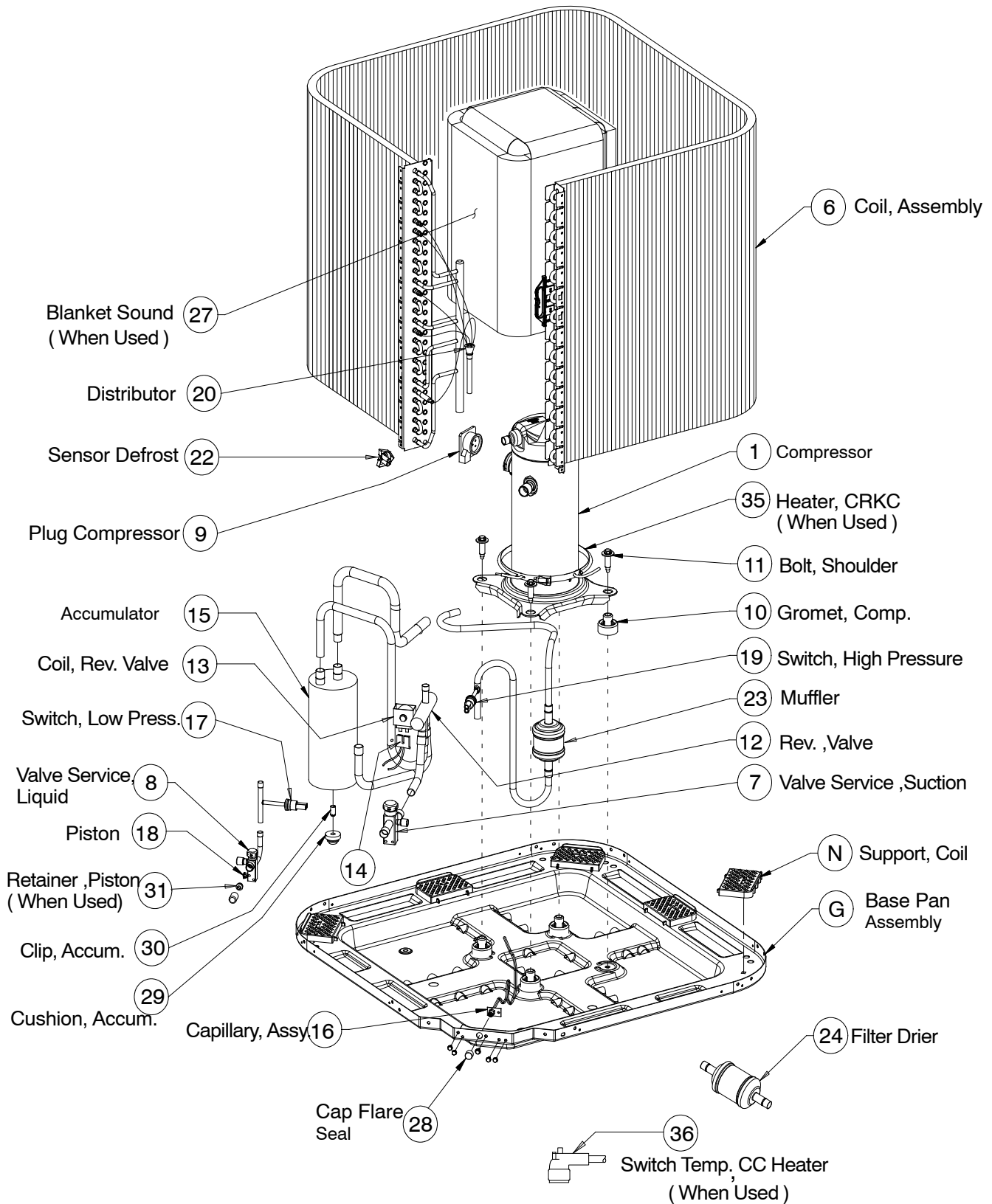

COOLING Multiplying Factors for other Indoor Combinations

NXH518

Indoor Model	Furnace Model	CAPACITY (MBh)	Power (AMPS)	Indoor Model	Furnace Model	CAPACITY (MBh)	Power (AMPS)
*FXM4X18**A*	-	1.00	1.00	EN(A,D)4X19*17**	*9MV*0601714A**	1.01	1.02
EA*4X18*14A*	*8MX*0451408**	0.98	1.03	ED*4X24F**	*9MA*0801714A**	0.99	1.04
EA*4X18*14A*	*8MV*0701412**	0.97	1.02	EN(A,D)4X24*17**	NOMV106D12*	1.00	1.01
EA*4X18*14A*	*9MX*0401410A**	0.97	1.06	EN(A,D)4X24*17**	OMV098J12A	1.01	1.02
EA*4X18*14A*	*9MV*0401410A**	0.97	1.06	EHD4X24A**	-	0.98	1.12
EA*4X24*14A*	*8MX*0451408**	1.01	1.04	EHD4X24A**	*9MA*0801714A**	0.99	1.04
EA*4X24*14A*	*8MV*0701412**	0.99	1.02	ENH4X24*17**	NOMV106D12*	1.00	1.01
EA*4X24*14A*	*9MX*0401410A**	0.99	1.06	ENH4X24*17**	OMV098J12A	1.01	1.02
EA*4X24*14A*	*9MV*0401410A**	0.99	1.06	EHD4X24A**	*8MPV050	0.98	0.99
EA*4X24*17A*	*8MV*0901716**	0.99	1.03	EN(A,D)4X19*17**	OLV098A12A	1.01	1.02
EA*4X24*17A*	*9MX*0401410A**	0.99	1.04	EA*4X24*14A*	-	0.99	1.12
EA*4X24*17A*	*9MV*0401410A**	1.00	1.07	EHD4X24A**	*9MPV050	0.98	1.03
EA*4X24*17A*	*9MV*0601714A**	1.01	1.06	EN(A,D)4X24*17**	*9MPV050	1.01	1.02
ED*4X18B**	*8MX*0451408**	0.98	1.03	EN(A,D)4X19*17**	*9MA*0801714A**	0.99	1.00
ED*4X18B**	*8MV*0701412**	0.97	1.01	EHD4X24A**	*9MVX040	0.98	1.03
ED*4X18B**	*9MX*0401410A**	0.97	1.06	EA*4X24*17A*	-	0.99	1.12
ED*4X18B**	*9MV*0401410A**	0.97	1.06	EHD4X24A**	*9MPV075	0.98	1.03
ED*4X24B**	*8MX*0451408**	0.99	1.00	EN(A,D)4X24*17**	*9MA*0801714A**	0.99	1.04
ED*4X24B**	*8MV*0701412**	0.98	0.99	EN(A,D)4X24*17**	*9MVX040	1.01	1.03
ED*4X24B**	*9MX*0401410A**	0.99	1.06	ED*4X18B**	-	0.97	1.11
ED*4X24B**	*9MV*0401410A**	0.99	1.06	EHD4X24A**	MV08B15**B*	0.98	0.99
ED*4X24F**	*8MV*0901716**	0.98	0.99	EN(A,D)4X24*17**	OLV098A12A	1.01	1.02
ED*4X24F**	*9MV*0601714A**	1.01	1.06	ENH4X24*17**	-	0.98	1.10
EHD4X24A**	*9MX*0401410A**	0.99	1.06	ED*4X18B**	*8MPV050	0.97	1.01
EHD4X24A**	*9MV*0401410A**	1.00	1.07	EHD4X24A**	*9MAC0602120A**	1.01	1.04
EHD4X24A**	*9MX*0601714A**	1.00	1.05	ENH4X24*17**	*9MPV050	1.01	1.02
EHD4X24A**	*8MX*0451408**	0.99	1.00	ENH4X24*17**	*9MA*0801714A**	0.99	1.04
EHD4X24A**	*8MV*0701412**	0.98	0.99	ENH4X24*17**	*9MVX040	1.01	1.03
EHD4X24A**	*8MV*0901716**	0.98	0.99	ED*4X24F**	NOMV106D12*	1.00	1.01
EN(A,D)4X18*14**	*8MX*0451408**	0.97	1.03	EHD4X24A**	*9MVX060	0.98	1.03
EN(A,D)4X18*14**	*8MV*0701412**	0.97	1.01	ED*4X18B**	MV08B15**B*	0.97	0.97
EN(A,D)4X18*14**	*9MX*0401410A**	0.98	1.04	EMA4X24D**	-	0.98	1.12
EN(A,D)4X18*14**	*9MV*0401410A**	0.98	1.07	ED*4X24F**	OMV098J12A	1.01	1.02
EN(A,D)4X19*17**	*8MV*0901716**	0.99	1.00				

COOLING Multiplying Factors for other Indoor Combinations

Indoor Model	Furnace Model	CAPACITY (MBh)	Power (AMPS)	Indoor Model	Furnace Model	CAPACITY (MBh)	Power (AMPS)
EN(A,D)4X19*17**	*9MX*0401410A**	0.99	1.04	ED*4X24B**	-	0.98	1.12
EN(A,D)4X19*17**	*9MV*0401410A**	1.01	1.06	EN(A,D)4X18*14**	-	0.97	1.09
EN(A,D)4X24*14**	*8MX*0451408**	0.99	1.00	EHD4X24A**	NOMV106D12*	1.01	1.01
EN(A,D)4X24*14**	*8MV*0701412**	0.98	0.99	ED*4X24F**	OLV098A12A	1.01	1.02
EN(A,D)4X24*14**	*9MX*0401410A**	0.98	1.05	ED*4X24B**	*8MPV050	0.98	0.99
EN(A,D)4X24*14**	*9MV*0401410A**	0.99	1.06	EN(A,D)4X19*17**	-	0.99	1.09
EN(A,D)4X24*17**	*8MV*0901716**	0.98	0.99	EHD4X24A**	OMV098J12A	1.01	1.02
EN(A,D)4X24*17**	*9MX*0401410A**	0.98	1.05	ED*4X24B**	MV08B15**B*	0.98	0.99
EN(A,D)4X24*17**	*9MV*0401410A**	0.99	1.06	EN(A,D)4X24*14**	-	0.98	1.10
ENH4X24*17**	*8MX*0451408**	0.99	1.00	EN(A,D)4X19*17**	NOMV106D12*	1.01	1.01
ENH4X24*17**	*8MV*0701412**	0.97	0.98	EHD4X24A**	OLV098A12A	1.01	1.02
ENH4X24*17**	*8MV*0901716**	0.98	0.99	EN(A,D)4X19*17**	OMV098J12A	1.01	1.02
ENH4X24*17**	*9MX*0401410A**	0.98	1.05	ED*4X24F**	-	0.98	1.12
ENH4X24*17**	*9MV*0401410A**	0.99	1.06	EN(A,D)4X24*17**	-	0.98	1.10
FEA4X18**A*	-	0.99	1.04	EN(A,D)4X24*17**	*9MV*0601714A**	1.00	1.05
FEA4X24**A*	-	1.00	1.01	EN(A,D)4X24*17**	*9MV*0601714A**	1.00	1.05
FEM4P18**A*	-	0.99	1.00	EA*4X24*17A*	*9MV*0801716A**	1.01	1.02
FEM4P18**A*	-	0.99	1.04	ED*4X24F**	*9MV*0801716A**	1.01	1.02
FEM4P24**A*	-	0.99	1.00	EHD4X24A**	*9MV*0801716A**	1.01	1.01
FEM4P24**A*	-	0.99	1.04	EN(A,D)4X19*17**	*9MV*0801716A**	1.01	1.02
FEM4X18****	-	0.99	1.00	EN(A,D)4X24*17**	*9MV*0801716A**	1.01	1.02
FEM4X24****	-	1.00	1.01	ENH4X24*17**	*9MV*0802120A**	1.01	1.02
FS(M,U)4P18**A*	-	0.98	1.07	EHD4X24A**	*9MV*1002120A**	1.01	1.02
FS(M,U)4P18**A*	-	0.99	1.08	EHD4X24A**	*9MV*1002120A**	1.01	1.02
FS(M,U)4P24**A*	-	0.98	1.07	EA*4X24*17A*	*9MA*0601714A**	0.99	1.04
FS(M,U)4P24**A*	-	0.99	1.09	ED*4X24F**	*9MA*0601714A**	0.99	1.04
FS(M,U)4X18****	-	0.97	1.11	EHD4X24A**	*9MA*0601714A**	1.00	1.05
FSA4X18**A*	-	0.97	1.11	EN(A,D)4X19*17**	*9MA*0601714A**	1.00	1.05
FSA4X24**A*	-	0.98	1.12	EN(A,D)4X24*17**	*9MA*0601714A**	0.99	1.04
FVM4X24****	-	1.00	1.01	ENH4X24*17**	*9MA*0601714A**	0.99	1.04
FXM4X24**A*	-	1.01	1.01	EA*4X24*17A*	*9MA*0801714A**	0.99	1.04
		NXH524					
-	-	-	-	ENH4X30*17**	*9MPV050	1.00	1.01

COOLING Multiplying Factors for other Indoor Combinations

Indoor Model	Furnace Model	CAPACITY (MBh)	Power (AMPS)	Indoor Model	Furnace Model	CAPACITY (MBh)	Power (AMPS)
*FXM4X24**A*	-	1.00	1.00	EHD4X30A**	*9MA*0601714A**	0.99	0.99
EA*4X24*14A*	*8MX*0451408**	0.98	1.01	EHD4X30A**	*9MA*0802120A**	1.00	1.00
EA*4X24*14A*	*8MV*0701412**	0.98	1.00	EHD4X24A**	NOMV106D12*	0.98	0.99
EA*4X24*14A*	*9MX*0401410A**	0.98	1.07	ENH4X24*17**	*9MV*1002116A**	0.97	0.97
EA*4X24*14A*	*9MV*0401410A**	0.98	1.03	EA*4X30*14A*	-	0.99	1.11
EA*4X24*17A*	*8MV*0901716**	0.98	0.98	EHD4X24A**	*9MVX040	0.99	1.03
EA*4X24*17A*	*9MX*0401410A**	0.98	1.07	ENH4X30*17**	*9MV*1002116A**	0.99	0.98
EA*4X24*17A*	*9MX*0601714A**	0.98	0.98	ENH4X24*17**	OLV098A12A	0.99	1.03
EA*4X24*17A*	*9MV*0401410A**	0.98	1.03	EA*4X30*17A*	-	0.99	1.11
EA*4X24*17A*	*9MV*0601714A**	0.98	0.99	ED*4X30F**	*9MPV075	1.00	1.01
EA*4X24*17A*	*9MV*0801716A**	0.98	0.98	EHD4X24A**	MV12F19**B*	1.00	1.00
EA*4X24*17A*	*9MA*0601714A**	0.98	0.98	EN(A,D)4X30*17**	*9MPV075	1.00	1.04
EA*4X30*14A*	*8MX*0451408**	0.99	1.02	EHD4X24A**	*9MA*1002122A**	1.00	1.02
EA*4X30*14A*	*8MV*0701412**	0.98	1.01	EHD4X30A**	NOMV106D12*	0.99	0.99
EA*4X30*14A*	*9MX*0401410A**	0.99	1.08	ENH4X31*17**	*9MV*1002116A**	1.00	0.98
EA*4X30*14A*	*9MV*0401410A**	0.98	1.03	ED*4X24B**	-	0.98	1.10
EA*4X30*17A*	*8MV*0901716**	0.99	0.99	EHD4X30A**	*9MVX040	1.00	1.04
EA*4X30*17A*	*9MX*0401410A**	1.00	1.07	ED*4X24F**	*9MA*1002120A**	0.99	0.99
EA*4X30*17A*	*9MX*0601714A**	0.99	0.98	ENH4X30*17**	OLV098A12A	1.00	1.00
EA*4X30*17A*	*9MV*0401410A**	0.98	1.03	ED*4X24B**	*8MPV050	1.00	1.04
EA*4X30*17A*	*9MV*0601714A**	0.99	0.99	ED*4X30F**	MV12F19**B*	1.00	0.97
EA*4X30*17A*	*9MV*0801716A**	1.00	0.98	EHD4X24A**	*9MAC0602120A**	0.99	1.02
EA*4X30*17A*	*9MA*0601714A**	0.98	0.98	EN(A,D)4X31*17**	-	0.98	1.06
ED*4X24B**	*8MX*0451408**	0.98	0.98	EHD4X30A**	*9MA*1002122A**	1.00	1.00
ED*4X24B**	*8MV*0701412**	0.98	0.98	EN(A,D)4X24*17**	NOMV106D12*	0.98	0.98
ED*4X24B**	*9MX*0401410A**	0.98	1.07	ED*4X30F**	*9MA*1002120A**	1.00	0.99
ED*4X24B**	*9MV*0401410A**	0.98	1.03	ED*4X24B**	MV08B15**B*	0.99	0.99
ED*4X24F**	*8MV*0901716**	0.98	0.98	EN(A,D)4X24*17**	*9MVX040	0.98	1.02
ED*4X24F**	*9MX*0601714A**	0.98	0.98	ED*4X24F**	OMV098J12A	0.99	1.00
ED*4X24F**	*9MV*0601714A**	0.98	0.99	EHD4X24A**	-	0.98	1.10
ED*4X24F**	*9MV*0801716A**	0.98	0.98	EHD4X30A**	-	0.99	1.11
ED*4X24F**	*9MA*0601714A**	0.98	0.98	ENH4X24*17**	-	0.98	1.09
ED*4X30B**	*8MX*0451408**	0.98	0.98	EHD4X24A**	*9MA*1202422A**	1.00	1.00
ED*4X30B**	*8MV*0701412**	0.98	0.98	EN(A,D)4X30*17**	NOMV106D12*	0.98	0.98
ED*4X30B**	*9MX*0401410A**	0.99	1.08	EHD4X24A**	*9MA*1002120A**	1.00	1.00



COOLING Multiplying Factors for other Indoor Combinations

Indoor Model	Furnace Model	CAPACITY (MBh)	Power (AMPS)	Indoor Model	Furnace Model	CAPACITY (MBh)	Power (AMPS)
ED*4X30B**	*9MV*0401410A**	0.98	1.03	ED*4X24F**	-	0.98	1.10
ED*4X30F**	*8MV*0901716**	0.98	0.98	EN(A,D)4X30*17**	*9MVX040	1.00	1.04
ED*4X30F**	*9MX*0601714A**	0.99	0.98	ED*4X30F**	OMV098J12A	1.00	1.00
ED*4X30F**	*9MV*0601714A**	0.99	0.99	EHD4X24A**	*8MPV050	1.00	1.04
ED*4X30F**	*9MV*0801716A**	1.00	0.98	EHD4X30A**	*8MPV050	1.00	1.04
ED*4X30F**	*9MA*0601714A**	0.98	0.98	ENH4X24*17**	*9MPV050	0.98	1.02
EHD4X24A**	*9MX*0401410A**	0.99	1.08	EHD4X30A**	*9MA*1002120A**	1.00	0.99
EHD4X24A**	*9MX*0601714A**	0.98	0.98	EHD4X24A**	OMV098J12A	1.00	1.04
EHD4X24A**	*9MV*0401410A**	0.98	1.03	ED*4X24F**	*8MPV075	1.00	1.00
EHD4X24A**	*9MV*0601714A**	0.98	0.99	EHD4X24A**	*8MPV075	1.00	1.04
EHD4X24A**	*9MV*0801716A**	0.98	0.98	EHD4X30A**	*8MPV075	1.00	1.00
EHD4X24A**	*9MV*0802120A**	0.98	1.00	EHD4X30A**	MV12F19**B*	1.00	0.97
EHD4X24A**	*9MV*1002120A**	0.98	1.01	EMA4X24D**	-	0.98	1.10
EHD4X24A**	*9MV*1202422A**	0.98	0.98	EN(A,D)4X24*17**	-	0.98	1.09
EHD4X24A**	*9MA*0601714A**	0.99	1.00	ENH4X30*17**	-	0.98	1.09
EHD4X24A**	*8MX*0451408**	0.98	0.98	EHD4X30A**	*9MA*1202422A**	1.00	0.98
EHD4X24A**	*8MV*0701412**	0.98	0.98	EN(A,D)4X31*17**	NOMV106D12*	1.00	1.00
EHD4X24A**	*8MV*0901716**	0.98	0.98	ENH4X24*17**	*9MVX040	0.98	1.02
EHD4X24A**	*8MV*1102120**	0.98	0.98	EHD4X24A**	*9MVX080	1.00	1.04
EHD4X24A**	*8MV*1352422**	0.98	0.98	ED*4X24F**	*9MV*1002116A**	0.98	0.98
EHD4X30A**	*8MX*0451408**	0.98	0.98	ENH4X24*17**	*9MA*1202422A**	0.98	0.98
EHD4X30A**	*8MV*0701412**	0.98	0.98	ENH4X30*17**	NOMV106D12*	0.98	0.98
EHD4X30A**	*8MV*1102120**	0.98	0.98	EHD4X30A**	*9MVX040	1.00	1.04
EHD4X30A**	*8MV*1352422**	0.98	0.98	ED*4X30F**	*9MVX080	1.00	1.00
EHD4X30A**	*9MX*0401410A**	1.00	1.06	ENH4X24*17**	*9MV*1002116A**	0.99	0.98
EHD4X30A**	*9MV*0601714A**	0.99	0.98	EHD4X30A**	*9MA*1002120A**	0.99	1.00
EHD4X30A**	*9MV*0401410A**	0.98	1.03	ED*4X24F**	OMV098J12A	1.00	1.00
EHD4X30A**	*9MV*0601714A**	0.99	0.99	EHD4X24A**	*9MPV050	0.99	1.03
EHD4X30A**	*9MV*0801716A**	1.00	0.98	EHD4X30A**	*8MPV100	1.00	1.00
EHD4X30A**	*9MV*0802120A**	1.00	1.00	EHD4X30A**	*8MPV100	1.00	1.00
EHD4X30A**	*9MV*1002120A**	1.00	1.00	ENH4X30A**	*9MAC0602120A**	1.00	1.02
EHD4X30A**	*9MV*1202422A**	1.00	1.00	EN(A,D)4X24*14**	-	0.98	1.09
EN(A,D)4X24*14**	*8MX*0451408**	0.98	0.98	EN(A,D)4X24*17**	*9MPV050	0.98	1.02
EN(A,D)4X24*14**	*8MV*0701412**	0.98	0.98	ENH4X30*17**	*9MA*1202422A**	0.99	0.98
				ENH4X30*17**	NOMV106D12*	0.98	0.98

COOLING Multiplying Factors for other Indoor Combinations

Indoor Model	Furnace Model	CAPACITY (MBh)	Power (AMPS)	Indoor Model	Furnace Model	CAPACITY (MBh)	Power (AMPS)
EN(A,D)4X24*14**	*9MX*0401410A**	0.98	1.07	ENH4X30*17**	*9MA*1002120A**	1.00	0.99
EN(A,D)4X24*14**	*9MV*0401410A**	0.97	1.03	ED*4X24F**	*9MPV075	0.99	1.03
EN(A,D)4X24*17**	*8MV*0901716**	0.98	0.98	ED*4X24F**	*9MVX060	1.00	1.04
EN(A,D)4X24*17**	*9MX*0401410A**	0.98	1.07	ENH4X31*17**	*9MA*1002120A**	1.00	0.98
EN(A,D)4X24*17**	*9MX*0601714A**	0.98	0.98	EN(A,D)4X24*17**	OMV098J12A	0.99	1.03
EN(A,D)4X24*17**	*9MV*0401410A**	0.97	1.03	ED*4X24F**	MV12F19**B*	0.99	0.99
EN(A,D)4X24*17**	*9MV*0601714A**	0.98	0.99	EHD4X24A**	*8MPV125	1.00	1.00
EN(A,D)4X24*17**	*9MV*0801716A**	0.98	0.98	EHD4X30A**	*8MPV125	1.00	1.00
EN(A,D)4X30*14**	*8MX*0451408**	0.98	0.98	ENH4X31*17**	*9MA*1202422A**	1.00	0.98
EN(A,D)4X30*14**	*8MV*0701412**	0.98	0.98	ENH4X31*17**	NOMV106D12*	1.00	1.00
EN(A,D)4X30*14**	*9MX*0401410A**	0.99	1.08	ED*4X24F**	OLV098A12A	0.99	0.99
EN(A,D)4X30*14**	*9MV*0401410A**	0.98	1.03	ED*4X30B**	-	0.99	1.11
EN(A,D)4X30*17**	*8MV*0901716**	0.98	0.98	ED*4X30F**	*9MVX060	1.00	1.00
EN(A,D)4X30*17**	*9MX*0401410A**	1.00	1.07	ED*4X30F**	OLV098A12A	1.00	1.00
EN(A,D)4X30*17**	*9MX*0601714A**	0.99	0.98	EN(A,D)4X30*17**	OMV098J12A	1.00	1.00
EN(A,D)4X30*17**	*9MV*0401410A**	0.98	1.03	ED*4X30B**	*8MPV050	1.00	1.04
EN(A,D)4X30*17**	*9MV*0601714A**	0.99	0.99	EHD4X24A**	*9MPV050	0.99	1.03
EN(A,D)4X30*17**	*9MV*0801716A**	1.00	0.98	EHD4X30A**	*9MPV050	1.00	1.04
EN(A,D)4X31*17**	*8MV*0901716**	0.98	0.94	EHD4X24A**	*9MVX060	1.00	1.04
EN(A,D)4X31*17**	*9MX*0401410A**	1.00	1.05	EHD4X24A**	OLV098A12A	1.00	1.00
EN(A,D)4X31*17**	*9MX*0601714A**	1.00	0.98	ENH4X24*17**	OMV098J12A	0.99	1.03
EN(A,D)4X31*17**	*9MV*0401410A**	1.00	1.04	ED*4X30B**	MV08B15**B*	1.00	1.00
EN(A,D)4X31*17**	*9MV*0601714A**	1.00	0.98	EHD4X24A**	*9MPV075	0.99	1.03
EN(A,D)4X31*17**	*9MV*0801716A**	1.00	0.98	EHD4X30A**	*9MPV075	1.00	1.04
ENH4X24*17**	*8MX*0451408**	0.98	1.02	ED*4X24F**	NOMV106D12*	0.98	0.98
ENH4X24*17**	*8MV*0701412**	0.98	0.98	ED*4X24F**	*9MVX040	0.99	1.03
ENH4X24*17**	*8MV*0901716**	0.98	0.98	EHD4X30A**	*9MVX060	1.00	1.04
ENH4X24*17**	*8MV*1102120**	0.98	0.98	EHD4X24A**	*9MVX100	1.00	1.00
ENH4X24*17**	*8MV*1352422**	0.98	0.98	EHD4X24A**	*9MV*1002116A**	0.97	0.97
ENH4X24*17**	*9MX*0401410A**	0.98	1.07	EHD4X30A**	OLV098A12A	1.00	1.00
ENH4X24*17**	*9MX*0601714A**	0.98	0.98	ENH4X30*17**	OMV098J12A	1.00	1.00
ENH4X24*17**	*9MV*0401410A**	0.97	1.03	ED*4X30F**	-	0.99	1.11
ENH4X24*17**	*9MV*0601714A**	0.98	0.99	EHD4X24A**	*9MPV100	1.00	1.04
ENH4X24*17**	*9MV*0801716A**	0.98	0.98	EHD4X30A**	*9MPV100	1.00	1.00
ENH4X24*17**	*9MV*1202422A**	0.98	0.98	EN(A,D)4X30*14**	-	0.98	1.09

COOLING Multiplying Factors for other Indoor Combinations

Indoor Model	Furnace Model	CAPACITY (MBh)	Power (AMPS)	Indoor Model	Furnace Model	CAPACITY (MBh)	Power (AMPS)
ENH4X30*17**	*8MX*0451408**	0.98	0.98	ED*4X30F**	NOMV106D12*	0.98	0.98
ENH4X30*17**	*8MV*0701412**	0.98	0.98	ED*4X30F**	*9MVX040	1.00	1.01
ENH4X30*17**	*8MV*0901716**	0.98	0.98	EN(A,D)4X30*17**	*9MVX060	1.00	1.00
ENH4X30*17**	*8MV*1102120**	0.98	0.98	EHD4X30A**	*9MVX100	1.00	1.00
ENH4X30*17**	*8MV*1352422**	0.98	0.98	EHD4X30A**	*9MV*1002116A**	0.99	0.98
ENH4X30*17**	*9MX*0401410A**	1.00	1.07	EN(A,D)4X24*17**	OLV098A12A	0.99	1.03
ENH4X30*17**	*9MX*0601714A**	0.99	0.98	EA*4X24*14A*	-	0.98	1.10
ENH4X30*17**	*9MV*0401410A**	0.98	1.03	ED*4X30F**	*8MPV075	1.00	1.00
ENH4X30*17**	*9MV*0601714A**	0.99	0.99	EHD4X24A**	*9MPV125	1.00	1.00
ENH4X30*17**	*9MV*0801716A**	1.00	0.98	EHD4X30A**	*9MPV125	1.00	1.00
ENH4X30*17**	*9MV*1202422A**	1.00	0.98	EN(A,D)4X30*17**	-	0.98	1.09
ENH4X31*17**	*9MX*0401410A**	1.00	1.05	EN(A,D)4X30*17**	OLV098A12A	1.00	1.00
ENH4X31*17**	*9MX*0601714A**	1.00	0.98	EA*4X24*17A*	-	0.98	1.10
ENH4X31*17**	*9MV*0401410A**	1.00	1.04	ED*4X30F**	*9MPV050	1.00	1.01
ENH4X31*17**	*9MV*0601714A**	1.00	0.98	EHD4X24A**	MV08B15**B*	0.99	0.99
ENH4X31*17**	*9MV*0801716A**	1.00	0.98	EHD4X30A**	MV08B15**B*	1.00	0.97
ENH4X31*17**	*9MV*1202422A**	1.00	0.96	EN(A,D)4X30*17**	*9MPV050	1.00	1.01
FEA4X24**A*	-	1.00	1.04	EN(A,D)4X24*17**	*9MA*0601714A**	0.98	0.99
FEA4X30**A*	-	1.00	1.04	EN(A,D)4X30*17**	*9MA*0601714A**	0.98	0.98
FEM4P24**A*	-	0.98	1.02	EN(A,D)4X31*17**	*9MA*0601714A**	1.00	0.98
FEM4P24**A*	-	0.98	1.06	ENH4X24*17**	*9MA*0601714A**	0.98	0.99
FEM4P30**A*	-	1.00	1.00	ENH4X30*17**	*9MA*0601714A**	0.98	0.98
FEM4P30**A*	-	1.00	1.04	ENH4X31*17**	*9MA*0601714A**	1.00	0.98
FEM4X24****	-	0.99	1.03	EA*4X24*17A*	*9MA*0801714A**	0.98	0.98
FEM4X30****	-	1.00	1.00	EA*4X30*17A*	*9MA*0801714A**	0.98	0.98
FS(M,U)4P24**A*	-	0.98	1.02	ED*4X24F**	*9MA*0801714A**	0.98	0.98
FS(M,U)4P24**A*	-	0.99	1.08	ED*4X30F**	*9MA*0801714A**	0.98	0.98
FS(M,U)4P30**A*	-	0.98	1.02	EHD4X24A**	*9MA*0801714A**	0.98	0.98
FS(M,U)4P30**A*	-	1.00	1.09	EHD4X30A**	*9MA*0801714A**	0.99	0.98
FS(M,U)4X24****	-	0.98	1.09	EN(A,D)4X24*17**	*9MA*0801714A**	0.98	0.98
FS(M,U)4X30****	-	0.99	1.11	EN(A,D)4X30*17**	*9MA*0801714A**	0.98	0.98
FSA4X24**A*	-	0.98	1.09	EN(A,D)4X31*17**	*9MA*0801714A**	1.00	0.98
FSA4X30**A*	-	0.98	1.10	ENH4X24*17**	*9MA*0801714A**	0.98	0.98
FVM4X24****	-	1.00	1.00	ENH4X30*17**	*9MA*0801714A**	0.98	0.98
FVM4X36****	-	1.00	1.00	ENH4X31*17**	*9MA*0801714A**	1.00	0.98

COOLING Multiplying Factors for other Indoor Combinations

Indoor Model	Furnace Model	CAPACITY (MBh)	Power (AMPS)	Indoor Model	Furnace Model	CAPACITY (MBh)	Power (AMPS)
FXM4X30**A*	-	1.00	1.00	EHD4X24A**	*9MA*0802120A**	1.00	1.02
Indoor Model	Furnace Model	CAPACITY (MBh)	Power (AMPS)	Indoor Model	Furnace Model	CAPACITY (MBh)	Power (AMPS)
NXH530							
*FXM4X30**A*	-	1.00	1.00	ENH4X36*17**	*9MA*0601714A**	0.97	1.01
EA*4X30*14A*	*8MV*0701412**	0.97	1.01	EN(A,D)4X31*17**	*9MVX040	0.99	1.03
EA*4X30*14A*	*9MV*0401410A**	0.95	1.08	ED*4X30F**	*8MPV075	0.98	1.02
EA*4X30*17A*	*8MX*0701716**	0.97	1.01	EHD4X30A**	*9MA*1002122A**	0.99	1.01
EA*4X30*17A*	*8MV*0901716**	0.97	1.00	ENH4X36*17**	*9MVX060	0.97	1.01
EA*4X30*17A*	*9MX*0601714A**	0.97	1.01	ED*4X30F**	OMV098J12A	0.97	1.01
EA*4X30*17A*	*9MX*0801716A**	0.98	1.02	EN(A,D)4X31*17**	OMV112K14A	1.00	1.00
EA*4X30*17A*	*9MV*0401410A**	0.95	1.08	ED*4X30F**	*9MPV050	0.97	1.01
EA*4X30*17A*	*9MV*0601714A**	0.97	1.01	EHD4X30A**	-	0.97	1.09
EA*4X30*17A*	*9MV*0801716A**	0.97	1.01	EHD4X36A**	*8MPV100	0.99	0.99
EA*4X30*17A*	*9MA*0601714A**	0.97	1.01	EN(A,D,W)4X36*17**	-	0.97	1.09
EA*4X36*14A*	*8MV*0701412**	0.97	1.00	EN(A,D)4X36*21**	*9MVX040	0.97	1.01
EA*4X36*14A*	*9MV*0401410A**	0.95	1.08	ED*4X30F**	*9MPV075	0.97	1.01
EA*4X36*17A*	*8MX*0701716**	0.98	1.02	EHD4X36A**	*9MA*1002122A**	1.00	0.98
EA*4X36*17A*	*8MV*0901716**	0.97	0.97	ED*4X36J**	*9MVX080	0.99	0.99
EA*4X36*17A*	*9MX*0601714A**	0.98	1.02	ED*4X36F**	OMV098J12A	0.97	1.01
EA*4X36*17A*	*9MX*0801716A**	0.99	1.03	EN(A,D)4X36*21**	OMV112K14A	0.98	0.98
EA*4X36*17A*	*9MV*0401410A**	0.96	1.09	ED*4X30F**	MV12F19**B*	0.98	0.98
EA*4X36*17A*	*9MV*0601714A**	0.97	1.01	EHD4X30A**	*8MPV050	0.97	1.06
EA*4X36*17A*	*9MV*0801716A**	0.98	1.02	EHD4X36A**	*8MPV125	0.99	0.99
EA*4X36*17A*	*9MA*0601714A**	0.97	1.01	EN(A,D,W)4X36*17**	*9MPV050	0.97	1.01
EA*4X36*21A*	*8MX*0902116**	0.99	1.01	EN(A,D,W)4X36*17**	NOMV106D12*	0.97	0.97
EA*4X36*21A*	*8MV*1102120**	0.98	0.98	EHD4X36A**	*9MA*1002120A**	1.00	1.00
EA*4X36*21A*	*9MX*0601714A**	0.98	1.02	EHD4X30A**	OMV098J12A	0.97	1.01
EA*4X36*21A*	*9MX*0801716A**	0.99	1.03	EN(A,D,W)4X36*17**	OMV112K14A	0.97	0.97
EA*4X36*21A*	*9MV*0601714A**	0.97	1.01	EHD4X30A**	*8MPV075	0.98	1.02
EA*4X36*21A*	*9MV*0801716A**	0.98	1.02	EHD4X36A**	*9MPV050	0.97	1.01
EA*4X36*21A*	*9MV*0802120A**	0.98	0.98	EN(A,D)4X30*17**	*9MPV075	0.97	1.01
EA*4X36*21A*	*9MV*1002120A**	0.98	0.98	EN(A,D)4X31*17**	*9MPV075	0.99	1.03
EA*4X36*21A*	*9MA*0601714A**	0.97	1.01	EN(A,D,W)4X36*17**	*9MPV075	0.97	1.01
ED*4X30B**	*8MV*0701412**	0.97	1.01	EN(A,D,W)4X36*17**	*9MVX040	0.97	1.01

COOLING Multiplying Factors for other Indoor Combinations

Indoor Model	Furnace Model	CAPACITY (MBh)	Power (AMPS)	Indoor Model	Furnace Model	CAPACITY (MBh)	Power (AMPS)
ED*4X30B**	*8MV*0701412**	0.97	1.01	ENH4X30*17**	*9MVX040	0.97	1.01
ED*4X30B**	*9MV*0401410A**	0.95	1.08	ED*4X36B**	-	0.97	1.09
ED*4X30F**	*8MX*0701716**	0.97	1.01	EN(A,D)4X36*21**	*9MA*1002122A**	0.98	1.00
ED*4X30F**	*8MX*0701716**	0.97	1.01	EHD4X30A**	*9MA*1202422A**	0.98	1.02
ED*4X30F**	*8MV*0901716**	0.97	0.97	EHD4X30A**	*9MVX080	0.99	1.03
ED*4X30F**	*8MV*0901716**	0.97	0.97	EHD4X36A**	*9MVX080	0.99	0.99
ED*4X30F**	*9MX*0601714A**	0.97	1.01	EHD4X36A**	OMV098J12A	0.99	1.00
ED*4X30F**	*9MX*0801716A**	0.98	1.02	ENH4X30*17**	OMV112K14A	0.97	0.97
ED*4X30F**	*9MV*0601714A**	0.97	1.01	EHD4X30A**	*8MPV100	0.99	0.99
ED*4X30F**	*9MV*0801716A**	0.97	1.01	EHD4X36A**	*9MPV075	0.98	1.02
ED*4X30F**	*9MA*0601714A**	0.97	1.01	ENH4X30*17**	-	0.97	1.09
ED*4X36B**	*8MV*0701412**	0.97	1.01	ENH4X31*17**	*9MVX040	0.99	1.03
ED*4X36B**	*8MV*0701412**	0.97	1.01	ENH4X36*17**	*9MVX040	0.97	1.01
ED*4X36B**	*9MV*0401410A**	0.95	1.08	ED*4X36B**	*8MPV050	0.97	1.06
ED*4X36F**	*8MX*0701716**	0.98	1.02	EHD4X36A**	*9MA*1202422A**	1.00	1.00
ED*4X36F**	*8MX*0701716**	0.98	1.02	ENH4X30*17**	*9MA*1202422A**	0.98	0.98
ED*4X36F**	*8MV*0901716**	0.97	0.97	EN(A,D)4X36*21**	*9MVX080	0.99	0.99
ED*4X36F**	*8MV*0901716**	0.97	0.97	ENH4X36*17**	*9MVX080	0.99	0.99
ED*4X36F**	*9MX*0601714A**	0.98	1.02	EN(A,D)4X30*17**	OMV098J12A	0.97	1.01
ED*4X36F**	*9MX*0601714A**	0.98	1.02	EN(A,D)4X31*17**	OMV098J12A	0.99	1.00
ED*4X36F**	*9MX*0801716A**	0.99	1.03	ENH4X31*17**	OMV112K14A	1.00	1.00
ED*4X36F**	*9MX*0801716A**	0.99	1.03	ENH4X36*17**	OMV112K14A	0.97	0.97
ED*4X36F**	*9MV*0601714A**	0.97	1.01	EHD4X30A**	*8MPV125	0.99	0.99
ED*4X36F**	*9MV*0801716A**	0.98	1.02	EHD4X36A**	*9MPV100	0.99	0.99
ED*4X36F**	*9MA*0601714A**	0.97	1.01	ENH4X30*17**	-	0.97	1.09
ED*4X36J**	*8MX*0902116**	0.98	0.98	ENH4X30*17**	*9MPV050	0.97	1.01
ED*4X36J**	*8MX*0902116**	0.98	0.98	EN(A,D,W)4X36*17**	NOMV106D12*	0.97	0.97
ED*4X36J**	*8MV*1102120**	0.97	0.97	ENH4X30*17**	NOMV106D12*	0.97	0.97
ED*4X36J**	*8MV*1102120**	0.97	0.97	EN(A,D)4X36*21**	*9MA*1002120A**	0.98	1.02
ED*4X36J**	*9MV*1202422A**	0.99	0.99	ENH4X30*17**	*9MA*1002120A**	0.98	1.02
EHD4X30A**	*8MX*0701716**	0.97	1.01	EN(A,D)4X36*21**	*9MPV075	0.97	1.01
EHD4X30A**	*8MX*0701716**	0.97	1.01	ENH4X36*17**	*9MA*1202422A**	0.98	0.98
EHD4X30A**	*8MX*0902116**	0.97	1.01	ENH4X30*17**	NOMV106D12*	0.97	0.97
EHD4X30A**	*8MX*0902116**	0.97	1.01	ENH4X31*17**	NOMV106D12*	0.97	0.97

COOLING Multiplying Factors for other Indoor Combinations

Indoor Model	Furnace Model	CAPACITY (MBh)	Power (AMPS)	Indoor Model	Furnace Model	CAPACITY (MBh)	Power (AMPS)
EHD4X30A**	*8MV*0701412**	0.97	1.01	ED*4X30F**	*9MVX060	0.98	1.02
EHD4X30A**	*8MV*0701412**	0.97	1.01	ED*4X36F**	*9MVX060	0.98	1.02
EHD4X30A**	*8MV*0901716**	0.97	0.97	EHD4X30A**	*9MVX100	0.98	0.98
EHD4X30A**	*8MV*0901716**	0.97	0.97	EHD4X36A**	*9MVX100	1.00	1.00
EHD4X30A**	*8MV*1102120**	0.97	0.97	ENH4X31*17**	*9MA*1002120A**	1.00	1.00
EHD4X30A**	*8MV*1102120**	0.97	0.97	ENH4X36*17**	*9MA*1002120A**	0.98	1.02
EHD4X30A**	*8MV*1352422**	0.97	0.97	ENH4X30*17**	OLV098A12A	0.97	1.01
EHD4X30A**	*8MV*1352422**	0.97	0.97	ENH4X31*17**	OLV098A12A	0.99	0.99
EHD4X30A**	*9MX*0601714A**	0.98	1.02	EN(A,D)4X36*21**	OMV098J12A	0.97	1.01
EHD4X30A**	*9MX*0801716A**	0.99	1.03	EA*4X30*14A*	-	0.97	1.09
EHD4X30A**	*9MV*0401410A**	0.96	1.09	ED*4X36B**	MV08B15**B*	0.98	0.98
EHD4X30A**	*9MV*0601714A**	0.97	1.01	EHD4X30A**	*9MPV050	0.97	1.01
EHD4X30A**	*9MV*0801716A**	0.97	1.01	EHD4X36A**	*9MPV125	1.01	1.01
EHD4X30A**	*9MV*0802120A**	0.97	1.00	EN(A,D)4X31*17**	-	1.00	1.09
EHD4X30A**	*9MV*1002120A**	0.97	0.99	EN(A,D)4X36*21**	-	0.97	1.09
EHD4X30A**	*9MV*1202422A**	0.98	0.98	EN(A,D)4X36*21**	*9MPV100	0.98	0.99
EHD4X30A**	*9MA*0601714A**	0.97	1.01	ENH4X30*17**	*9MPV075	0.97	1.01
EHD4X36A**	*8MX*0701716**	0.98	1.02	ED*4X30F**	NOMV106D12*	0.97	0.97
EHD4X36A**	*8MX*0701716**	0.98	1.02	ED*4X30F**	NOMV106D12*	0.97	0.97
EHD4X36A**	*8MX*0902116**	0.98	0.98	ENH4X31*17**	NOMV106D12*	0.99	0.99
EHD4X36A**	*8MX*0902116**	0.98	0.98	ENH4X36*17**	NOMV106D12*	0.97	0.97
EHD4X36A**	*8MV*0701412**	0.97	1.01	EHD4X30A**	*9MVX060	0.98	1.02
EHD4X36A**	*8MV*0701412**	0.97	1.01	EHD4X36A**	*9MVX060	0.98	1.02
EHD4X36A**	*8MV*0901716**	0.97	0.97	EA*4X36*21A*	*9MV*1002116A**	0.98	0.98
EHD4X36A**	*8MV*0901716**	0.97	0.97	ED*4X30F**	*9MV*1002116A**	0.97	1.01
EHD4X36A**	*8MV*1102120**	0.97	0.97	ED*4X30F**	OLV098A12A	0.97	1.01
EHD4X36A**	*8MV*1102120**	0.97	0.97	ED*4X36F**	OLV098A12A	0.97	1.01
EHD4X36A**	*8MV*1352422**	0.97	0.97	ENH4X36*17**	OLV098A12A	0.98	1.02
EHD4X36A**	*8MV*1352422**	0.97	0.97	ED*4X30F**	OLV112A16A	0.98	1.02
EHD4X36A**	*9MX*0401410A**	0.99	1.12	EN(A,D)4X36*21**	OLV112A16A	0.98	1.02
EHD4X36A**	*9MX*0601714A**	1.00	1.04	EN(A,D,W)4X36*17**	OMV098J12A	0.97	1.01
EHD4X36A**	*9MX*0801716A**	1.01	1.01	EA*4X30*17A*	-	0.97	1.09
EHD4X36A**	*9MV*0401410A**	0.98	1.09	ED*4X36F**	-	0.97	1.09
EHD4X36A**	*9MV*0601714A**	0.99	1.03	EHD4X30A**	*9MPV075	0.97	1.01
EHD4X36A**	*9MV*0801716A**	0.99	0.99	EHD4X36A**	MV08B15**B*	0.98	0.98

COOLING Multiplying Factors for other Indoor Combinations

Indoor Model	Furnace Model	CAPACITY (MBh)	Power (AMPS)	Indoor Model	Furnace Model	CAPACITY (MBh)	Power (AMPS)
EHD4X36A**	*9MV*0802120A**	0.99	0.98	EN(A,D)4X31*17**	-	1.00	1.09
EHD4X36A**	*9MV*1002120A**	0.99	0.99	EN(A,D)4X36*21**	-	0.97	1.09
EHD4X36A**	*9MV*1202422A**	1.00	1.00	EN(A,D)4X36*21**	*9MAC0602120A**	0.97	1.01
EHD4X36A**	*9MA*0601714A**	0.99	1.03	ENH4X31*17**	*9MPV050	0.99	1.03
EN(A,D)4X30*14**	*8MV*0701412**	0.97	1.01	EN(A,D)4X30*17**	*9MVX060	0.97	1.01
EN(A,D)4X30*14**	*8MV*0701412**	0.97	1.01	EN(A,D)4X31*17**	*9MVX060	1.00	1.01
EN(A,D)4X30*14**	*9MV*0401410A**	0.95	1.08	ED*4X36F**	*8MPV075	0.99	1.03
EN(A,D)4X30*17**	*8MX*0701716**	0.97	1.01	ED*4X36F**	NOMV106D12*	0.97	0.97
EN(A,D)4X30*17**	*8MX*0701716**	0.97	1.01	ED*4X36F**	NOMV106D12*	0.97	0.97
EN(A,D)4X30*17**	*8MV*0901716**	0.97	0.97	ED*4X36F**	*9MV*1002116A**	0.98	1.02
EN(A,D)4X30*17**	*8MV*0901716**	0.97	0.97	ED*4X36J**	*9MV*1002116A**	0.98	0.98
EN(A,D)4X30*17**	*9MX*0601714A**	0.97	1.01	ENH4X30*17**	OMV098J12A	0.97	1.01
EN(A,D)4X30*17**	*9MX*0801716A**	0.98	1.02	EA*4X36*14A*	-	0.97	1.09
EN(A,D)4X30*17**	*9MV*0401410A**	0.95	1.08	ED*4X36F**	*9MPV050	0.97	1.01
EN(A,D)4X30*17**	*9MV*0601714A**	0.97	1.01	EHD4X30A**	*9MPV100	0.98	1.02
EN(A,D)4X30*17**	*9MV*0801716A**	0.97	1.01	EHD4X36A**	MV12F19**B*	0.99	0.99
EN(A,D)4X30*17**	*9MA*0601714A**	0.97	1.01	ENH4X31*17**	*9MPV075	0.99	1.03
EN(A,D)4X31*17**	*8MX*0701716**	1.00	1.00	EHD4X30A**	NOMV106D12*	0.97	0.97
EN(A,D)4X31*17**	*8MX*0701716**	1.00	1.00	EHD4X30A**	NOMV106D12*	0.97	0.97
EN(A,D)4X31*17**	*8MV*0901716**	0.99	0.99	EHD4X30A**	*9MV*1002116A**	0.97	1.01
EN(A,D)4X31*17**	*8MV*0901716**	0.99	0.99	EHD4X36A**	*9MV*1002116A**	0.99	0.99
EN(A,D)4X31*17**	*9MX*0401410A**	0.99	1.12	ENH4X30*17**	OLV112A16A	0.98	1.02
EN(A,D)4X31*17**	*9MX*0601714A**	1.00	1.04	ENH4X31*17**	OMV098J12A	0.99	0.99
EN(A,D)4X31*17**	*9MX*0801716A**	1.01	1.01	EA*4X36*17A*	-	0.97	1.09
EN(A,D)4X31*17**	*9MV*0401410A**	0.98	1.09	ED*4X36F**	*9MPV075	0.98	1.02
EN(A,D)4X31*17**	*9MV*0601714A**	0.99	1.03	EHD4X30A**	*9MPV125	0.98	0.98
EN(A,D)4X31*17**	*9MV*0801716A**	0.99	0.99	EHD4X36A**	*9MAC0602120A**	0.99	1.02
EN(A,D)4X31*17**	*9MA*0601714A**	0.99	1.03	ENH4X31*17**	-	1.00	1.09
EN(A,D)4X36*21**	*8MX*0902116**	0.98	0.98	ENH4X36*17**	NOMV106D12*	0.97	0.97
EN(A,D)4X36*21**	*8MX*0902116**	0.98	0.98	ED*4X30F**	*9MVX040	0.97	1.01
EN(A,D)4X36*21**	*8MV*1102120**	0.97	0.97	EHD4X30A**	OLV098A12A	0.97	1.01
EN(A,D)4X36*21**	*8MV*1102120**	0.97	0.97	EHD4X36A**	OLV098A12A	0.99	0.99
EN(A,D)4X36*21**	*9MX*0601714A**	0.97	1.01	ENH4X36*17**	OMV098J12A	0.97	1.01
EN(A,D)4X36*21**	*9MX*0801716A**	0.99	1.03	EA*4X36*21A*	*9MAC0602120A**	0.98	1.00
EN(A,D)4X36*21**	*9MV*0601714A**	0.97	1.01	EHD4X30A**	MV08B15**B*	0.98	0.98

COOLING Multiplying Factors for other Indoor Combinations

Indoor Model	Furnace Model	CAPACITY (MBh)	Power (AMPS)	Indoor Model	Furnace Model	CAPACITY (MBh)	Power (AMPS)
EN(A,D)4X36*21**	*9MV*0801716A**	0.97	1.01	EMA4X36D**	-	0.97	1.09
EN(A,D)4X36*21**	*9MV*0802120A**	0.97	1.00	EN(A,D)4X31*17**	*9MPV050	0.99	1.03
EN(A,D)4X36*21**	*9MV*1002120A**	0.97	0.99	EN(A,D)4X36*21**	*9MPV050	0.97	1.01
EN(A,D)4X36*21**	*9MA*0601714A**	0.97	1.01	ENH4X36*17**	-	0.97	1.09
EN(A,D)4X37*17**	*8MX*0701716**	1.01	1.01	EHD4X36A**	NOMV106D12*	0.98	0.98
EN(A,D)4X37*17**	*8MX*0701716**	1.01	1.01	EHD4X36A**	NOMV106D12*	0.98	0.98
EN(A,D)4X37*17**	*8MV*0901716**	1.01	0.97	EN(A,D)4X36*21**	*9MV*1002116A**	0.97	1.01
EN(A,D)4X37*17**	*8MV*0901716**	1.01	0.97	ENH4X30*17**	*9MV*1002116A**	0.97	1.01
EN(A,D)4X37*17**	*9MX*0401410A**	1.00	1.14	ENH4X31*17**	OLV112A16A	1.00	1.00
EN(A,D)4X37*17**	*9MX*0601714A**	1.01	1.01	ED*4X30F**	OMV112K14A	0.97	0.97
EN(A,D)4X37*17**	*9MX*0801716A**	1.02	1.02	EA*4X36*21A*	-	0.97	1.09
EN(A,D)4X37*17**	*9MV*0401410A**	0.99	1.09	ED*4X36F**	MV12F19**B*	0.99	0.99
EN(A,D)4X37*17**	*9MV*0601714A**	1.01	1.01	EHD4X30A**	MV12F19**B*	0.98	0.98
EN(A,D)4X37*17**	*9MV*0801716A**	1.01	1.01	EN(A,D)4X30*14**	-	0.97	1.09
EN(A,D)4X37*17**	*9MA*0601714A**	1.00	1.00	ENH4X36*17**	-	0.97	1.09
EN(A,D,W)4X36*17**	*8MX*0701716**	0.97	1.01	EN(A,D)4X30*17**	NOMV106D12*	0.97	0.97
EN(A,D,W)4X36*17**	*8MX*0701716**	0.97	1.01	EN(A,D)4X30*17**	NOMV106D12*	0.97	0.97
EN(A,D,W)4X36*17**	*8MV*0901716**	0.97	0.97	ENH4X31*17**	*9MV*1002116A**	0.99	0.99
EN(A,D,W)4X36*17**	*8MV*0901716**	0.97	0.97	ENH4X36*17**	*9MV*1002116A**	0.97	1.01
EN(A,D,W)4X36*17**	*9MX*0601714A**	0.97	1.01	ED*4X36F**	OMV112K14A	0.98	0.98
EN(A,D,W)4X36*17**	*9MX*0801716A**	0.98	1.02	ED*4X30B**	-	0.97	1.09
EN(A,D,W)4X36*17**	*9MV*0401410A**	0.95	1.08	ED*4X36J**	-	0.97	1.09
EN(A,D,W)4X36*17**	*9MV*0601714A**	0.97	1.01	EHD4X30A**	*9MAC0602120A**	0.98	1.02
EN(A,D,W)4X36*17**	*9MV*0801716A**	0.97	1.01	EN(A,D)4X30*14**	-	0.97	1.09
EN(A,D,W)4X36*17**	*9MA*0601714A**	0.97	1.01	ENH4X36*17**	*9MPV050	0.97	1.01
ENH4X30*17**	*8MX*0701716**	0.97	1.01	EN(A,D)4X31*17**	NOMV106D12*	0.99	0.99
ENH4X30*17**	*8MX*0701716**	0.97	1.01	EN(A,D)4X31*17**	NOMV106D12*	0.99	0.99
ENH4X30*17**	*8MX*0902116**	0.97	1.01	ED*4X36F**	*9MVX040	0.97	1.01
ENH4X30*17**	*8MX*0902116**	0.97	1.01	EHD4X30A**	*9MVX040	0.97	1.01
ENH4X30*17**	*8MV*0701412**	0.97	1.01	EN(A,D)4X36*21**	*9MVX060	0.98	1.02
ENH4X30*17**	*8MV*0701412**	0.97	1.01	EN(A,D,W)4X36*17**	*9MVX060	0.97	1.01
ENH4X30*17**	*8MV*0901716**	0.97	0.97	EA*4X36*21A*	*9MA*1002120A**	0.98	0.98
ENH4X30*17**	*8MV*0901716**	0.97	0.97	ED*4X36F**	*9MA*1002120A**	0.98	1.02
ENH4X30*17**	*8MV*1102120**	0.97	0.97	EN(A,D)4X30*17**	OLV098A12A	0.97	1.01
ENH4X30*17**	*8MV*1102120**	0.97	0.97	EN(A,D)4X31*17**	OLV098A12A	0.99	0.99



COOLING Multiplying Factors for other Indoor Combinations

Indoor Model	Furnace Model	CAPACITY (MBh)	Power (AMPS)	Indoor Model	Furnace Model	CAPACITY (MBh)	Power (AMPS)
ENH4X30*17**	*8MV*1352422**	0.97	0.97	ED*4X36F**	OLV112A16A	0.98	0.98
ENH4X30*17**	*8MV*1352422**	0.97	0.97	ED*4X36J**	OLV112A16A	0.99	0.99
ENH4X30*17**	*9MX*0601714A**	0.97	1.01	EHD4X30A**	OMV112K14A	0.98	0.98
ENH4X30*17**	*9MX*0801716A**	0.98	1.02	ED*4X30B**	*8MPV050	0.97	1.06
ENH4X30*17**	*9MV*0401410A**	0.95	1.08	ED*4X36J**	*8MPV100	0.99	0.99
ENH4X30*17**	*9MV*0601714A**	0.97	1.01	EHD4X36A**	-	0.97	1.09
ENH4X30*17**	*9MV*0801716A**	0.97	1.01	EN(A,D)4X30*17**	-	0.97	1.09
ENH4X30*17**	*9MV*1202422A**	0.97	0.97	EN(A,D)4X37*17**	-	1.01	1.09
ENH4X30*17**	*9MA*0601714A**	0.97	1.01	ENH4X36*17**	*9MPV075	0.97	1.01
ENH4X31*17**	*9MX*0401410A**	0.99	1.12	ENH4X36*17**	OLV112A16A	0.98	1.02
ENH4X31*17**	*9MX*0601714A**	1.00	1.04	EHD4X36A**	OMV112K14A	1.00	1.00
ENH4X31*17**	*9MX*0801716A**	1.01	1.01	ED*4X30B**	MV08B15**B*	0.98	0.98
ENH4X31*17**	*9MV*0401410A**	0.98	1.09	ED*4X36J**	*8MPV125	0.99	0.99
ENH4X31*17**	*9MV*0601714A**	0.99	0.99	EHD4X36A**	*8MPV050	0.98	1.06
ENH4X31*17**	*9MV*0801716A**	0.99	0.99	EN(A,D)4X30*17**	-	0.97	1.09
ENH4X31*17**	*9MV*1202422A**	1.00	1.00	EN(A,D)4X37*17**	-	1.01	1.09
ENH4X31*17**	*9MA*0601714A**	0.99	1.03	ENH4X36*17**	*9MPV100	0.98	1.02
ENH4X36*17**	*8MX*0701716**	0.97	1.01	EN(A,D)4X37*17**	NOMV106D12*	0.99	0.99
ENH4X36*17**	*8MX*0701716**	0.97	1.01	EN(A,D)4X37*17**	NOMV106D12*	0.99	0.99
ENH4X36*17**	*8MX*0902116**	0.98	0.98	EHD4X36A**	*9MVX040	0.97	1.01
ENH4X36*17**	*8MX*0902116**	0.98	0.98	EN(A,D)4X30*17**	*9MVX040	0.97	1.01
ENH4X36*17**	*8MV*0701412**	0.97	1.01	ENH4X30*17**	*9MVX060	0.97	1.01
ENH4X36*17**	*8MV*0701412**	0.97	1.01	ENH4X31*17**	*9MVX060	1.00	1.01
ENH4X36*17**	*8MV*0901716**	0.97	0.97	ED*4X36J**	*9MA*1002120A**	0.98	0.98
ENH4X36*17**	*8MV*0901716**	0.97	0.97	EHD4X30A**	*9MA*1002120A**	0.98	1.02
ENH4X36*17**	*8MV*1102120**	0.97	0.97	EN(A,D)4X36*21**	OLV098A12A	0.97	1.01
ENH4X36*17**	*8MV*1102120**	0.97	0.97	EN(A,D,W)4X36*17**	OLV098A12A	0.97	1.01
ENH4X36*17**	*8MV*1352422**	0.97	0.97	EHD4X30A**	OLV112A16A	0.99	1.03
ENH4X36*17**	*8MV*1352422**	0.97	0.97	EHD4X36A**	OLV112A16A	1.00	1.00
ENH4X36*17**	*9MX*0601714A**	0.97	1.01	EN(A,D)4X30*17**	OMV112K14A	0.97	0.97
ENH4X36*17**	*9MX*0801716A**	0.98	1.02	ED*4X30F**	-	0.97	1.09
ENH4X36*17**	*9MV*0401410A**	0.95	1.08	ED*4X36J**	*9MPV100	0.99	0.99
ENH4X36*17**	*9MV*0601714A**	0.97	1.01	EHD4X36A**	*8MPV075	0.99	1.03
ENH4X36*17**	*9MV*0801716A**	0.97	1.01	EN(A,D)4X30*17**	*9MPV050	0.97	1.01
ENH4X36*17**	*9MV*1202422A**	0.97	0.97	EN(A,D,W)4X36*17**	-	0.97	1.09

COOLING Multiplying Factors for other Indoor Combinations

Indoor Model	Furnace Model	CAPACITY (MBh)	Power (AMPS)	Indoor Model	Furnace Model	CAPACITY (MBh)	Power (AMPS)
FEA4X30**A*	-	0.98	1.02	EA*4X30*17A*	*9MA*0801714A**	0.97	1.01
FEA4X36**A*	-	0.99	1.03	EA*4X36*17A*	*9MA*0801714A**	0.97	1.01
FEM4P30**A*	-	0.98	1.02	EA*4X36*21A*	*9MA*0801714A**	0.98	1.02
FEM4P30**A*	-	0.98	1.02	ED*4X30F**	*9MA*0801714A**	0.97	1.01
FEM4P36**A*	-	0.98	1.02	ED*4X36F**	*9MA*0801714A**	0.97	1.01
FEM4P36**A*	-	0.98	1.02	ED*4X36F**	*9MA*0801714A**	0.97	1.01
FEM4X30****	-	0.98	1.02	EHD4X30A**	*9MA*0801714A**	0.98	1.02
FEM4X36****	-	1.00	1.04	EHD4X36A**	*9MA*0801714A**	0.99	0.99
FS(M,U)4P30**A*	-	0.99	1.03	EN(A,D)4X30*17**	*9MA*0801714A**	0.97	1.01
FS(M,U)4P30**A*	-	0.99	1.03	EN(A,D)4X31*17**	*9MA*0801714A**	0.99	0.99
FS(M,U)4P36**A*	-	0.98	1.06	EN(A,D)4X36*21**	*9MA*0801714A**	0.97	1.01
FS(M,U)4P36**A*	-	0.98	1.06	EN(A,D)4X37*17**	*9MA*0801714A**	1.01	1.01
FS(M,U)4X30****	-	0.97	1.08	EN(A,D,W)4X36*17**	*9MA*0801714A**	0.97	1.01
FSA4X30**A*	-	0.96	1.07	ENH4X30*17**	*9MA*0801714A**	0.97	1.01
FSA4X36**A*	-	0.98	1.06	ENH4X31*17**	*9MA*0801714A**	0.99	0.99
FSM4X36****	-	0.99	1.08	ENH4X36*17**	*9MA*0801714A**	0.97	1.01
FSU4X36****	-	0.97	1.09	EA*4X36*21A*	*9MA*0802120A**	0.98	1.00
FVM4X24****	-	0.98	0.98	EHD4X30A**	*9MA*0802120A**	0.98	1.00
FVM4X36****	-	0.99	0.99	EHD4X36A**	*9MA*0802120A**	0.99	0.99
FVM4X48****	-	1.01	0.97	EN(A,D)4X36*21**	*9MA*0802120A**	0.97	1.00
FXM4X36**A*	-	1.00	1.00	EA*4X36*21A*	*9MA*1002122A**	0.99	0.99
<b>NXH536</b>							
*FXM4X36**A*	-	1.00	1.00	EN(A,D)4X37*17**	NOMV106D12*	0.99	1.03
EA*4X36*14A*	*8MX*0451408**	0.95	1.06	EN(A,D,W)4X36*17**	*9MVX040	0.95	1.07
EA*4X36*14A*	*8MV*0701412**	0.95	1.03	ED*4X42F**	*9MV*1002116A**	0.97	1.02
EA*4X36*17A*	*8MX*0701716**	0.96	1.04	ED*4X42F**	*9MVX060	0.97	1.05
EA*4X36*17A*	*8MV*0901716**	0.96	1.02	EN(A,D)4X43*24**	*9MV*1002116A**	0.99	0.99
EA*4X36*17A*	*9MX*0601714A**	0.96	1.04	EN(A,D,W)4X36*17**	OLV098A12A	0.95	1.03
EA*4X36*17A*	*9MX*0801716A**	0.95	1.01	ENH4X36*17**	OLV112A16A	0.96	1.04
EA*4X36*17A*	*9MV*0601714A**	0.95	1.04	EN(A,D,W)4X36*17**	OMV098J12A	0.95	1.03
EA*4X36*17A*	*9MV*0801716A**	0.96	1.01	END4X42*17**	OMV112K14A	0.98	1.01
EA*4X36*17A*	*9MA*0601714A**	0.95	1.03	EHD4X36A**	*8MPV075	0.97	1.05
EA*4X36*17A*	*9MA*0801714A**	0.95	1.00	EHD4X42A**	*9MPV050	0.97	1.07

COOLING Multiplying Factors for other Indoor Combinations

Indoor Model	Furnace Model	CAPACITY (MBh)	Power (AMPS)	Indoor Model	Furnace Model	CAPACITY (MBh)	Power (AMPS)
EA*4X36*21A*	*8MX*0902116**	0.97	1.01	ENH4X42*21**	*9MVX060	0.97	1.05
EA*4X36*21A*	*8MX*1102120**	0.98	1.01	ED*4X42L**	*9MVX100	0.98	1.02
EA*4X36*21A*	*8MV*1102120**	0.96	1.00	ED*4X36J**	*9MA*1002120A**	0.95	1.01
EA*4X36*21A*	*9MX*0601714A**	0.96	1.04	EN(A,D,W)4X42*21**	OLV098A12A	0.96	1.04
EA*4X36*21A*	*9MX*0801716A**	0.96	1.01	ENH4X42*21**	OLV112A16A	0.97	1.05
EA*4X36*21A*	*9MV*0601714A**	0.96	1.04	EN(A,D,W)4X42*21**	OMV098J12A	0.97	1.05
EA*4X36*21A*	*9MV*0801716A**	0.97	1.02	ENH4X36*17**	OMV112K14A	0.95	1.03
EA*4X36*21A*	*9MV*0802120A**	0.97	1.00	ED*4X36F**	*8MPV075	0.97	1.05
EA*4X36*21A*	*9MV*1002120A**	0.97	1.00	ED*4X36J**	*9MPV100	0.98	1.02
EA*4X36*21A*	*9MA*0601714A**	0.95	1.00	EHD4X36A**	*8MPV100	0.98	1.02
EA*4X36*21A*	*9MA*0801714A**	0.95	1.01	EHD4X42A**	*9MPV075	0.97	1.05
EA*4X36*21A*	*9MA*0802120A**	0.96	1.00	EN(A,D)4X37*17**	*9MPV050	0.99	1.08
EA*4X36*21A*	*9MA*1002122A**	0.96	1.00	EN(A,D,W)4X36*17**	*9MPV075	0.95	1.08
EA*4X42*21A*	*8MX*0902116**	0.98	1.01	ED*4X36J**	*9MVX080	0.98	1.06
EA*4X42*21A*	*8MX*1102120**	0.98	1.00	EHD4X36A**	*9MVX100	0.99	1.03
EA*4X42*21A*	*8MV*1102120**	0.97	1.01	ED*4X42J**	*9MA*1002120A**	0.97	1.00
EA*4X42*21A*	*9MX*0601714A**	0.97	1.05	END4X42*17**	OLV098A12A	0.97	1.05
EA*4X42*21A*	*9MX*0801716A**	0.97	1.02	ENH4X43*21**	OLV112A16A	1.00	1.04
EA*4X42*21A*	*9MX*0601714A**	0.97	1.05	END4X42*17**	OMV098J12A	0.97	1.05
EA*4X42*21A*	*9MV*0801716A**	0.97	1.02	ENH4X42*21**	OMV112K14A	0.97	1.01
EA*4X42*21A*	*9MV*0802120A**	0.97	1.01	ED*4X36F**	*9MPV050	0.95	1.06
EA*4X42*21A*	*9MV*1002120A**	0.97	1.01	ED*4X36J**	MV16J22**B*	0.97	0.97
EA*4X42*21A*	*9MA*0601714A**	0.95	1.01	EHD4X36A**	*8MPV125	0.98	1.02
EA*4X42*21A*	*9MA*0801714A**	0.96	1.01	EHD4X42A**	*9MPV100	0.98	1.02
EA*4X42*21A*	*9MA*0802120A**	0.97	1.00	EN(A,D)4X37*17**	*9MPV075	0.99	1.04
EA*4X42*21A*	*9MA*1002122A**	0.97	1.01	EN(A,D,W)4X42*21**	-	0.97	1.08
EA*4X42*24A*	*8MV*1352422**	0.97	0.99	ENH4X43*21**	*9MA*1002120A**	0.99	1.03
EA*4X42*24A*	*9MV*1202422A**	0.97	1.01	ED*4X42J**	-	0.97	1.08
EA*4X42*24A*	*9MA*1202422A**	0.97	1.00	END4X42*17**	*9MPV050	0.97	1.10
ED*4X36B**	*8MX*0451408**	0.95	1.08	EN(A,D,W)4X42*21**	*9MVX040	0.96	1.09
ED*4X36B**	*8MV*0701412**	0.95	1.03	ED*4X42J**	*9MA*1002116A**	0.97	1.02
ED*4X36F**	*8MX*0701716**	0.96	1.04	EHD4X36A**	*9MVX060	0.98	1.06
ED*4X36F**	*8MV*0901716**	0.96	1.00	EN(A,D,W)4X42*21**	*9MV*1002116A**	0.97	1.02
ED*4X36F**	*9MX*0601714A**	0.96	1.04	ENH4X36*17**	OLV098A12A	0.95	1.03
ED*4X36F**	*9MX*0601714A**	0.96	1.04	ENH4X42*21**	OLV098A12A	0.96	1.04

COOLING Multiplying Factors for other Indoor Combinations

Indoor Model	Furnace Model	CAPACITY (MBh)	Power (AMPS)	Indoor Model	Furnace Model	CAPACITY (MBh)	Power (AMPS)
ED*4X36F**	*9MX*0801716A**	0.95	1.01	ED*4X42L**	OLV154F20A	0.99	1.03
ED*4X36F**	*9MX*0801716A**	0.95	1.01	EHD4X36A**	OLV154F20A	1.01	1.04
ED*4X36F**	*9MV*0601714A**	0.95	1.04	ENH4X36*17**	OMV098J12A	0.95	1.03
ED*4X36F**	*9MV*0801716A**	0.96	1.01	ENH4X43*21**	OMV112K14A	0.99	1.03
ED*4X36F**	*9MA*0601714A**	0.95	1.03	EHD4X36A**	*9MPV050	0.95	1.06
ED*4X36F**	*9MA*0601714A**	0.95	1.03	EHD4X36A**	*9MPV075	0.96	1.04
ED*4X36F**	*9MA*0801714A**	0.95	1.00	EHD4X42A**	*9MPV125	0.99	1.03
ED*4X36F**	*9MA*0801714A**	0.95	1.00	EHD4X42A**	MV08B15**B*	0.99	0.98
ED*4X36F**	NOMV106D12*	0.95	1.03	ENH4X42*21**	*9MPV100	0.98	1.02
ED*4X36J**	*8MX*0902116**	0.97	1.01	ED*4X42J**	*9MVX080	0.99	1.03
ED*4X36J**	*8MX*1102120**	0.98	1.01	EHD4X42A**	*9MVX100	0.98	1.02
ED*4X36J**	*8MV*1102120**	0.96	1.00	ED*4X42L**	*9MA*1002120A**	0.97	1.00
ED*4X36J**	*9MV*1202422A**	0.97	1.00	ED*4X42J**	*8MPV100	0.99	1.03
ED*4X42F**	*9MX*0601714A**	0.97	1.05	ENH4X43*21**	OLV098A12A	0.99	1.03
ED*4X42F**	*9MX*0801716A**	0.97	1.02	EHD4X42A**	OLV154F20A	1.02	1.02
ED*4X42F**	*9MV*0601714A**	0.97	1.05	ENH4X42*21**	OMV098J12A	0.97	1.05
ED*4X42F**	*9MV*0801716A**	0.97	1.02	EA*4X36*14A*	-	0.95	1.08
ED*4X42F**	*9MA*0601714A**	0.95	1.01	EHD4X36A**	*9MPV100	0.98	1.01
ED*4X42F**	*9MA*0801714A**	0.96	1.01	EHD4X42A**	MV12F19**B*	0.98	0.97
ED*4X42J**	*8MX*0902116**	0.98	1.01	EHD4X36A**	*9MVX080	0.98	1.06
ED*4X42J**	*8MX*1102120**	0.98	1.02	EN(A,D)4X43*24**	*9MVX100	1.02	1.01
ED*4X42J**	*8MV*1102120**	0.97	1.01	EHD4X36A**	*9MA*1002120A**	0.98	1.01
ED*4X42L**	*9MV*1202422A**	0.97	1.01	ED*4X42J**	*8MPV125	0.99	1.03
ED*4X42L**	*8MV*1352422**	0.97	1.01	ED*4X36F**	OLV098A12A	0.95	1.03
ED*4X42L**	*9MV*1202422A**	0.97	1.01	ED*4X42J**	*9MPV100	0.98	1.02
ED*4X42L**	*9MA*1202422A**	0.97	1.00	END4X42*17**	*9MPV075	0.97	1.05
EHD4X36A**	*8MX*0451408**	0.96	1.04	END4X42*17**	*9MVX040	0.97	1.05
EHD4X36A**	*8MX*0701716**	0.96	1.00	EHD4X42A**	*9MVX060	0.97	1.05
EHD4X36A**	*8MX*0902116**	0.97	1.00	EHD4X42A**	*9MVX080	0.99	1.03
EHD4X36A**	*8MX*1102120**	0.97	1.01	ENH4X43*21**	*9MVX100	1.01	1.01
EHD4X36A**	*8MV*0701412**	0.96	1.00	ED*4X42L**	*9MV*1002116A**	0.97	1.02
EHD4X36A**	*8MV*0901716**	0.97	1.00	ENH4X36*17**	*9MV*1002116A**	0.95	1.03
EHD4X36A**	*8MV*1102120**	0.97	1.00	EHD4X42A**	*9MA*1002120A**	0.98	1.02
EHD4X36A**	*8MV*1352422**	0.97	1.00	ED*4X42F**	OLV098A12A	0.96	1.04
EHD4X36A**	*9MX*0601714A**	0.98	1.04	ED*4X36F**	OLV112A16A	0.97	1.05

COOLING Multiplying Factors for other Indoor Combinations

Indoor Model	Furnace Model	CAPACITY (MBh)	Power (AMPS)	Indoor Model	Furnace Model	CAPACITY (MBh)	Power (AMPS)
EHD4X36A**	*9MX*0801716A**	0.98	1.01	EN(A,D)4X43*24**	OLV154F20A	1.03	1.02
EHD4X36A**	*9MV*0601714A**	0.98	1.03	ENH4X43*21**	OMV098J12A	0.99	1.03
EHD4X36A**	*9MV*0801716A**	0.98	1.02	EA*4X36*17A*	-	0.97	1.09
EHD4X36A**	*9MV*0802120A**	0.98	1.02	ED*4X36F**	*9MPV075	0.96	1.04
EHD4X36A**	*9MV*1002120A**	0.98	1.00	ED*4X42F**	-	0.97	1.10
EHD4X36A**	*9MV*1202422A**	0.98	1.02	ED*4X42J**	MV16J22**B*	0.98	0.97
EHD4X36A**	*9MA*0601714A**	0.97	1.02	EHD4X36A**	*9MPV125	0.99	1.03
EHD4X36A**	*9MA*0801714A**	0.97	1.01	EHD4X42A**	MV16J22**B*	0.98	0.97
EHD4X36A**	*9MA*0802120A**	0.98	1.00	EN(A,D)4X43*24**	-	1.01	1.09
EHD4X36A**	*9MA*1002122A**	0.98	1.00	EN(A,D,W)4X42*21**	*9MPV050	0.96	1.09
EHD4X36A**	*9MA*1202422A**	0.98	1.01	ENH4X36*17**	-	0.97	1.09
EHD4X36A**	NOMV106D12*	0.97	1.01	ENH4X42*21**	*9MAC0602120A**	0.96	1.02
EHD4X42A**	*8MX*0451408**	0.97	1.08	ENH4X36*17**	*9MVX040	0.95	1.07
EHD4X42A**	*8MX*0701716**	0.97	1.01	EN(A,D)4X36*21**	*9MVX060	0.96	1.04
EHD4X42A**	*8MX*0902116**	0.98	1.02	EN(A,D)4X36*21**	*9MVX080	0.97	1.05
EHD4X42A**	*8MX*1102120**	0.98	1.02	EA*4X36*21A*	*9MV*1002116A**	0.97	1.02
EHD4X42A**	*8MV*0701412**	0.97	1.01	EHD4X36A**	*9MV*1002116A**	0.98	1.02
EHD4X42A**	*8MV*0901716**	0.97	1.01	ENH4X42*21**	*9MV*1002116A**	0.97	1.02
EHD4X42A**	*8MV*1102120**	0.98	1.01	EN(A,D)4X36*21**	*9MA*1002120A**	0.95	1.01
EHD4X42A**	*8MV*1352422**	0.98	1.01	EHD4X36A**	OLV098A12A	0.98	1.06
EHD4X42A**	*9MX*0601714A**	0.99	1.04	ED*4X36J**	OLV112A16A	0.97	1.01
EHD4X42A**	*9MX*0801716A**	0.98	1.02	ENH4X36*17**	OLV154F20A	0.98	1.02
EHD4X42A**	*9MV*0601714A**	0.98	1.04	ED*4X36F**	OMV112K14A	0.96	1.00
EHD4X42A**	*9MV*0801716A**	0.99	1.03	EA*4X36*21A*	*9MAC0602120A**	0.95	1.02
EHD4X42A**	*9MV*0802120A**	0.99	1.01	ED*4X36F**	MV12F19**B*	0.97	1.01
EHD4X42A**	*9MV*1002120A**	0.99	1.01	ED*4X42F**	*8MPV075	0.98	1.06
EHD4X42A**	*9MV*1202422A**	0.99	1.03	ED*4X42L**	-	0.97	1.08
EHD4X42A**	*9MA*0601714A**	0.97	1.02	EHD4X36A**	MV08B15**B*	0.97	1.01
EHD4X42A**	*9MA*0801714A**	0.98	1.01	EHD4X42A**	MV20L24**B*	0.98	0.97
EHD4X42A**	*9MA*0802120A**	0.98	1.00	EN(A,D)4X43*24**	*9MPV100	1.02	1.02
EHD4X42A**	*9MA*1002122A**	0.99	1.01	EN(A,D,W)4X42*21**	*9MPV075	0.97	1.05
EHD4X42A**	*9MA*1202422A**	0.98	1.02	ENH4X36*17**	*9MPV050	0.95	1.07
EHD4X42A**	NOMV106D12*	0.98	1.01	ENH4X43*21**	*9MPV100	1.02	1.06
EN(A,D)4X36*21**	*8MX*0902116**	0.97	1.00	EN(A,D)4X43*24**	*9MVX080	1.02	1.03
EN(A,D)4X36*21**	*8MX*1102120**	0.97	1.00	EA*4X42*21A*	*9MV*1002116A**	0.97	1.02

COOLING Multiplying Factors for other Indoor Combinations

Indoor Model	Furnace Model	CAPACITY (MBh)	Power (AMPS)	Indoor Model	Furnace Model	CAPACITY (MBh)	Power (AMPS)
EN(A,D)4X36*21**	*8MV*1102120**	0.96	1.00	EN(A,D)4X43*24**	*9MA*1002120A**	0.99	0.99
EN(A,D)4X36*21**	*9MX*0601714A**	0.95	1.04	ED*4X42F**	OLV112A16A	0.97	1.01
EN(A,D)4X36*21**	*9MX*0801716A**	0.95	1.01	ENH4X42*21**	OLV154F20A	0.99	1.03
EN(A,D)4X36*21**	*9MV*0601714A**	0.95	1.04	ED*4X42F**	OMV112K14A	0.97	1.00
EN(A,D)4X36*21**	*9MV*0801716A**	0.96	1.04	EA*4X36*21A*	-	0.97	1.09
EN(A,D)4X36*21**	*9MV*0802120A**	0.95	1.02	ED*4X36J**	-	0.97	1.09
EN(A,D)4X36*21**	*9MV*1002120A**	0.95	1.02	ED*4X42F**	*9MPV050	0.96	1.07
EN(A,D)4X36*21**	*9MA*0601714A**	0.94	1.03	EHD4X36A**	MV12F19**B*	0.97	1.01
EN(A,D)4X36*21**	*9MA*0801714A**	0.95	1.00	EHD4X42A**	*9MAC0602120A**	0.98	1.01
EN(A,D)4X36*21**	*9MA*0802120A**	0.95	1.02	EN(A,D)4X43*24**	*9MPV125	1.02	1.01
EN(A,D)4X36*21**	*9MA*1002122A**	0.96	1.02	EN(A,D,W)4X42*21**	*9MPV100	0.98	1.02
EN(A,D)4X37*17**	*8MX*0701716**	0.99	1.03	EN(A,D)4X37*17**	*9MVX060	1.00	1.04
EN(A,D)4X37*17**	*8MV*0901716**	0.99	0.99	ENH4X43*21**	*9MV*1002116A**	0.99	1.03
EN(A,D)4X37*17**	*9MX*0601714A**	0.99	1.03	ED*4X42J**	OLV112A16A	0.97	1.01
EN(A,D)4X37*17**	*9MX*0801716A**	0.99	1.03	ENH4X43*21**	OLV154F20A	1.02	1.02
EN(A,D)4X37*17**	*9MV*0801716A**	0.98	1.02	EA*4X42*21A*	*9MAC0602120A**	0.96	1.02
EN(A,D)4X37*17**	*9MA*0601714A**	0.98	1.02	EHD4X36A**	MV16J22**B*	0.97	0.97
EN(A,D)4X37*17**	*9MA*0601714A**	0.98	1.02	EHD4X36A**	MV20L24**B*	0.98	0.97
EN(A,D)4X37*17**	*9MA*0801714A**	0.98	1.02	EMA4X36D**	-	0.97	1.09
EN(A,D)4X43*24**	*8MV*1352422**	1.00	1.00	EHD4X42A**	OLV098A12A	0.98	1.02
EN(A,D)4X43*24**	*9MV*1202422A**	0.99	0.99	ED*4X42L**	*9MPV125	0.99	1.03
EN(A,D)4X43*24**	*9MA*1202422A**	0.99	0.99	ENH4X36*17**	*9MPV075	0.95	1.08
EN(A,D,W)4X36*17**	*8MX*0701716**	0.95	1.03	EN(A,D,W)4X36*17**	*9MVX060	0.96	1.09
EN(A,D,W)4X36*17**	*8MV*0901716**	0.96	1.00	EA*4X36*21A*	*9MA*1002120A**	0.95	1.01
EN(A,D,W)4X36*17**	*9MX*0601714A**	0.95	1.04	ED*4X42L**	OLV112A16A	0.97	1.01
EN(A,D,W)4X36*17**	*9MX*0801716A**	0.95	1.01	ED*4X36F**	OMV098J12A	0.95	1.03
EN(A,D,W)4X36*17**	*9MV*0601714A**	0.95	1.04	EHD4X36A**	OMV112K14A	0.98	1.02
EN(A,D,W)4X36*17**	*9MV*0801716A**	0.95	1.03	EA*4X42*21A*	-	0.97	1.10
EN(A,D,W)4X36*17**	*9MA*0601714A**	0.94	1.03	EHD4X36A**	*9MAC0602120A**	0.97	1.01
EN(A,D,W)4X36*17**	*9MA*0801714A**	0.95	1.03	EN(A,D)4X36*21**	-	0.97	1.09
EN(A,D,W)4X42*21**	*8MX*0902116**	0.98	1.01	EN(A,D,W)4X42*21**	*9MVX080	0.98	1.02
EN(A,D,W)4X42*21**	*8MX*1102120**	0.98	1.01	EA*4X42*24A*	*9MV*1002116A**	0.97	1.02
EN(A,D,W)4X42*21**	*8MV*1102120**	0.97	1.01	EN(A,D,W)4X42*21**	*9MA*1002120A**	0.97	1.02
EN(A,D,W)4X42*21**	*9MX*0601714A**	0.97	1.05	EHD4X36A**	OLV112A16A	0.98	1.02
EN(A,D,W)4X42*21**	*9MX*0801716A**	0.97	1.02	ED*4X42F**	OMV098J12A	0.97	1.05

COOLING Multiplying Factors for other Indoor Combinations

Indoor Model	Furnace Model	CAPACITY (MBh)	Power (AMPS)	Indoor Model	Furnace Model	CAPACITY (MBh)	Power (AMPS)
EN(A,D,W)4X42*21**	*9MV*0601714A**	0.97	1.05	EHD4X42A**	OMV112K14A	0.99	1.03
EN(A,D,W)4X42*21**	*9MV*0801716A**	0.97	1.02	EA*4X42*24A*	-	0.97	1.10
EN(A,D,W)4X42*21**	*9MV*0802120A**	0.97	1.00	ED*4X36J**	*8MPV100	0.98	1.02
EN(A,D,W)4X42*21**	*9MV*1002120A**	0.97	1.00	ED*4X42F**	*9MPV075	0.97	1.05
EN(A,D,W)4X42*21**	*9MA*0601714A**	0.95	1.03	EHD4X42A**	-	0.97	1.08
EN(A,D,W)4X42*21**	*9MA*0801714A**	0.96	1.01	EN(A,D)4X36*21**	*9MPV050	0.95	1.07
EN(A,D,W)4X42*21**	*9MA*0802120A**	0.97	1.00	EN(A,D,W)4X36*17**	-	0.97	1.09
EN(A,D,W)4X42*21**	*9MA*1002122A**	0.97	1.01	EN(A,D,W)4X42*21**	*9MAC0602120A**	0.96	1.02
END4X42*17**	*8MX*0701716**	0.98	1.02	EN(A,D,W)4X42*21**	*9MVX060	0.97	1.05
END4X42*17**	*8MV*0901716**	0.98	1.01	EA*4X42*21A*	*9MA*1002120A**	0.97	1.00
END4X42*17**	*9MX*0601714A**	0.98	1.03	EHD4X42A**	OLV112A16A	0.99	1.03
END4X42*17**	*9MX*0801716A**	0.97	1.01	EHD4X36A**	OMV098J12A	0.98	1.06
END4X42*17**	*9MV*0601714A**	0.97	1.05	EN(A,D)4X36*21**	OMV112K14A	0.96	1.04
END4X42*17**	*9MV*0801716A**	0.98	1.03	ED*4X36B**	-	0.95	1.08
END4X42*17**	*9MA*0601714A**	0.96	1.01	EHD4X42A**	*8MPV050	0.98	1.06
END4X42*17**	*9MA*0801714A**	0.97	1.00	EN(A,D)4X36*21**	*9MPV075	0.95	1.08
ENH4X36*17**	*8MX*0451408**	0.95	1.06	ENH4X42*21**	*9MVX040	0.96	1.09
ENH4X36*17**	*8MX*0701716**	0.95	1.03	END4X42*17**	*9MVX060	0.98	1.06
ENH4X36*17**	*8MX*0902116**	0.96	1.00	ENH4X42*21**	*9MVX080	0.98	1.02
ENH4X36*17**	*8MX*1102120**	0.97	1.00	ED*4X36F**	*9MV*1002116A**	0.96	1.01
ENH4X36*17**	*8MV*0701412**	0.95	1.03	EHD4X42A**	*9MV*1002116A**	0.99	1.03
ENH4X36*17**	*8MV*0901716**	0.96	1.00	EA*4X42*24A*	*9MA*1002120A**	0.97	1.00
ENH4X36*17**	*8MV*1102120**	0.96	1.00	ENH4X36*17**	*9MA*1002120A**	0.95	1.01
ENH4X36*17**	*8MV*1352422**	0.96	1.00	EN(A,D)4X36*21**	OLV098A12A	0.95	1.03
ENH4X36*17**	*9MX*0601714A**	0.95	1.04	EN(A,D)4X36*21**	OLV112A16A	0.96	1.04
ENH4X36*17**	*9MX*0801716A**	0.95	1.01	EHD4X42A**	OMV098J12A	0.98	1.02
ENH4X36*17**	*9MV*0601714A**	0.95	1.04	EN(A,D)4X37*17**	OMV112K14A	0.99	1.03
ENH4X36*17**	*9MV*0801716A**	0.95	1.03	ED*4X36B**	*8MPV050	0.95	1.07
ENH4X36*17**	*9MV*1202422A**	0.95	1.01	ED*4X42L**	MV20L24**B*	0.98	0.97
ENH4X36*17**	*9MA*0601714A**	0.94	1.03	EHD4X42A**	*8MPV075	0.98	1.06
ENH4X36*17**	*9MA*0801714A**	0.95	1.03	EN(A,D)4X36*21**	*9MPV100	0.97	1.05
ENH4X36*17**	*9MA*1202422A**	0.95	1.01	ENH4X42*21**	-	0.97	1.08
ENH4X42*21**	*8MX*0451408**	0.97	1.07	ED*4X36F**	*9MVX060	0.96	1.04
ENH4X42*21**	*8MX*0701716**	0.97	1.05	ENH4X36*17**	*9MVX060	0.96	1.09
ENH4X42*21**	*8MX*0902116**	0.98	1.01	ENH4X43*21**	*9MVX080	1.02	1.06

COOLING Multiplying Factors for other Indoor Combinations

Indoor Model	Furnace Model	CAPACITY (MBh)	Power (AMPS)	Indoor Model	Furnace Model	CAPACITY (MBh)	Power (AMPS)
ENH4X42*21**	*8MX*1102120**	0.98	1.01	ED*4X36J**	*9MV*1002116A**	0.97	1.02
ENH4X42*21**	*8MV*0701412**	0.97	1.00	EN(A,D)4X36*21**	*9MV*1002116A**	0.96	1.01
ENH4X42*21**	*8MV*0901716**	0.97	1.00	ED*4X36F**	*9MA*1002120A**	0.95	1.01
ENH4X42*21**	*8MV*1102120**	0.97	1.01	ENH4X42*21**	*9MA*1002120A**	0.97	1.02
ENH4X42*21**	*8MV*1352422**	0.97	1.01	EN(A,D)4X37*17**	OLV098A12A	0.99	1.03
ENH4X42*21**	*9MX*0601714A**	0.97	1.05	EN(A,D)4X43*24**	OLV112A16A	1.01	1.01
ENH4X42*21**	*9MX*0801716A**	0.97	1.02	EN(A,D)4X36*21**	OMV098J12A	0.95	1.03
ENH4X42*21**	*9MV*0601714A**	0.97	1.05	EN(A,D,W)4X36*17**	OMV112K14A	0.95	1.03
ENH4X42*21**	*9MV*0801716A**	0.97	1.02	ED*4X36B**	MV08B15**B*	0.97	1.00
ENH4X42*21**	*9MV*0802120A**	0.97	1.00	ED*4X36J**	*8MPV125	0.98	1.02
ENH4X42*21**	*9MV*1002120A**	0.97	1.00	ED*4X42F**	MV12F19**B*	0.98	0.97
ENH4X42*21**	*9MV*1202422A**	0.97	1.00	EHD4X36A**	-	0.97	1.09
ENH4X42*21**	*9MA*0601714A**	0.95	1.03	EHD4X42A**	*8MPV100	0.99	1.03
ENH4X42*21**	*9MA*0801714A**	0.96	1.01	EN(A,D)4X36*21**	*9MAC0602120A**	0.95	1.01
ENH4X42*21**	*9MA*0802120A**	0.97	1.00	EN(A,D,W)4X36*17**	*9MPV050	0.95	1.07
ENH4X42*21**	*9MA*1002122A**	0.97	1.01	END4X42*17**	-	0.98	1.09
ENH4X42*21**	*9MA*1202422A**	0.97	1.00	ENH4X42*21**	*9MPV050	0.96	1.09
ENH4X43*21**	*9MX*0601714A**	1.00	1.04	EN(A,D,W)4X42*21**	OLV112A16A	0.97	1.05
ENH4X43*21**	*9MX*0801716A**	0.99	1.03	EN(A,D)4X37*17**	OMV098J12A	0.99	1.03
ENH4X43*21**	*9MV*0601714A**	0.98	1.02	EN(A,D,W)4X42*21**	OMV112K14A	0.97	1.01
ENH4X43*21**	*9MV*0801716A**	0.99	1.03	ED*4X36F**	-	0.97	1.09
ENH4X43*21**	*9MV*1202422A**	0.99	0.98	EHD4X36A**	*8MPV050	0.97	1.05
ENH4X43*21**	*9MA*0601714A**	0.98	1.02	EHD4X42A**	*8MPV125	0.99	1.03
ENH4X43*21**	*9MA*0801714A**	0.99	1.03	EN(A,D)4X37*17**	-	1.01	1.09
ENH4X43*21**	*9MA*1202422A**	0.99	0.99	ENH4X42*21**	*9MPV075	0.97	1.05
FEA4X36**A*	-	0.97	1.07	EN(A,D,W)4X36*17**	NOMV106D12*	0.95	1.03
FEM4P36**A*	-	0.97	1.05	END4X42*17**	NOMV106D12*	0.97	1.01
FEM4P36**A*	-	0.97	1.07	ENH4X36*17**	NOMV106D12*	0.95	1.03
FEM4P42**A*	-	1.00	1.04	ENH4X42*21**	NOMV106D12*	0.96	1.00
FEM4P42**A*	-	1.01	1.04	ENH4X43*21**	NOMV106D12*	0.99	1.03
FEM4X36****	-	0.99	1.03	ED*4X36J**	NOMV156E19*	0.96	1.00
FEM4X42****	-	0.99	1.03	ED*4X42J**	NOMV156E19*	0.97	1.00
FS(M,U)4P36**A*	-	0.97	1.05	EHD4X36A**	NOMV156E19*	0.98	1.01
FS(M,U)4P36**A*	-	0.98	1.06	EHD4X42A**	NOMV156E19*	0.98	1.02
FS(M,U)4P42**A*	-	0.99	1.07	EN(A,D)4X36*21**	NOMV156E19*	0.95	0.99



COOLING Multiplying Factors for other Indoor Combinations

Indoor Model	Furnace Model	CAPACITY (MBh)	Power (AMPS)	Indoor Model	Furnace Model	CAPACITY (MBh)	Power (AMPS)
FS(M,U)4P42**A*	-	0.99	1.08	EN(A,D,W)4X42*21**	NOMV156E19*	0.97	1.00
FS(M,U)4X42****	-	0.98	1.11	ENH4X36*17**	NOMV156E19*	0.95	1.03
FSA4X36**A*	-	0.97	1.09	ENH4X42*21**	NOMV156E19*	0.97	1.00
FSM4X36****	-	0.98	1.11	ENH4X43*21**	NOMV156E19*	0.99	0.99
FSU4X36****	-	0.97	1.09	ED*4X36F**	*9MVX040	0.95	1.06
FVM4X24****	-	0.97	1.00	ED*4X42F**	*9MVX040	0.96	1.07
FVM4X36****	-	0.97	0.98	EHD4X36A**	*9MVX040	0.98	1.09
FVM4X48****	-	1.01	1.00	EHD4X42A**	*9MVX040	0.96	1.07
FVM4X60****	-	1.02	0.97	EN(A,D)4X36*21**	*9MVX040	0.95	1.07
FXM4X42**A*	-	1.00	1.00	EN(A,D)4X37*17**	*9MVX040	0.99	1.07
-	-	-	-	ENH4X43*21**	*9MPV125	1.02	1.01
Indoor Model	Furnace Model	CAPACITY (MBh)	Power (AMPS)	Indoor Model	Furnace Model	CAPACITY (MBh)	Power (AMPS)
<b>NXH537</b>							
*FXM4X36**A*	-	1.00	1.00	ENH4X43*21**	*9MVX040	0.99	1.07
ED*4X36B**	*8MPV050	0.94	1.10	ENH4X36*17**	*9MVX100	0.96	1.04
ED*4X36F**	*8MPV075	0.96	1.03	ENH4X36*17**	MV08B15**B*	0.96	1.00
ED*4X36F**	*9MPV050	0.95	1.10	EHD4X42A**	OMV098J12A	0.99	1.03
ED*4X36F**	*9MPV075	0.96	1.03	ENH4X43*21**	OMV098J12A	0.99	1.03
ED*4X36F**	*9MVX040	0.95	1.07	EN(A,D,W)4X36*17**	-	0.96	1.09
ED*4X36J**	*8MPV100	0.98	1.02	ENH4X36*17**	MV12F19**B*	0.97	1.00
ED*4X36J**	*8MPV125	0.98	1.02	ENH4X36*17**	MV16J22**B*	0.97	1.00
ED*4X36J**	*9MPV100	0.97	1.01	EN(A,D,W)4X42*21**	OMV112K14A	0.97	1.01
ED*4X42F**	*8MPV075	0.97	1.01	ENH4X42*21**	MV08B15**B*	0.97	1.01
ED*4X42F**	*9MPV050	0.96	1.09	EN(A,D)4X36*21**	OMV098J12A	0.96	1.03
ED*4X42F**	*9MPV075	0.96	1.04	ED*4X36F**	OMV112K14A	0.96	1.00
ED*4X42F**	*9MVX040	0.96	1.09	EN(A,D,W)4X42*21**	-	0.97	1.10
ED*4X42J**	*8MPV100	0.99	1.03	ENH4X42*21**	MV12F19**B*	0.98	0.98
ED*4X42J**	*8MPV125	0.99	1.03	ENH4X42*21**	MV16J22**B*	0.98	0.98
ED*4X42J**	*9MPV100	0.98	1.02	END4X42*17**	OMV112K14A	0.98	1.02
ED*4X42L**	*8MV*1352422**	0.97	1.00	ED*4X42F**	OLV098A12A	0.96	1.04
ED*4X42L**	*9MPV125	0.98	1.02	ED*4X42L**	-	0.97	1.13
EHD4X36A**	*8MPV050	0.97	1.05	ENH4X42*21**	*9MVX100	0.98	1.02
EHD4X36A**	*8MPV075	0.99	1.03	ENH4X43*21**	MV08B15**B*	1.00	1.00
EHD4X36A**	*8MPV100	1.00	1.04	ENH4X43*21**	MV12F19**B*	1.00	1.00

COOLING Multiplying Factors for other Indoor Combinations

Indoor Model	Furnace Model	CAPACITY (MBh)	Power (AMPS)	Indoor Model	Furnace Model	CAPACITY (MBh)	Power (AMPS)
EHD4X36A**	*8MPV125	1.00	1.00	ENH4X43*21**	MV16J22**B*	1.00	1.00
EHD4X36A**	*8MV*0701412**	0.98	1.02	ENH4X36*17**	MV20L24**B*	0.97	1.00
EHD4X36A**	*8MV*0901716**	0.98	1.02	EN(A,D)4X37*17**	NOMV106D12*	0.98	1.02
EHD4X36A**	*8MV*1102120**	0.98	1.02	ED*4X42L**	NOMV156E19*	-	-
EHD4X36A**	*8MV*1352422**	0.98	1.02	EHD4X36A**	OLV098A12A	0.98	1.06
EHD4X36A**	*8MX*0451408**	0.98	1.06	END4X42*17**	OLV098A12A	0.97	1.05
EHD4X36A**	*8MX*0701716**	0.98	1.06	ED*4X36J**	OLV112A16A	0.97	1.00
EHD4X36A**	*8MX*0902116**	0.99	1.03	EN(A,D,W)4X42*21**	OLV112A16A	0.98	1.02
EHD4X36A**	*8MX*1102120**	0.99	0.99	EN(A,D)4X43*24**	OLV154F20A	1.01	1.05
EHD4X36A**	*9MPV050	0.97	1.05	EN(A,D)4X37*17**	OMV098J12A	0.99	1.03
EHD4X36A**	*9MPV075	0.98	1.06	ED*4X42F**	OMV112K14A	0.97	1.01
EHD4X36A**	*9MPV100	0.99	1.03	ENH4X36*17**	OMV112K14A	0.96	1.04
EHD4X36A**	*9MPV125	0.99	1.03	EHD4X36A**	-	0.99	1.15
EHD4X36A**	*9MVX040	0.97	1.05	END4X42*17**	-	0.98	1.11
EHD4X42A**	*8MPV050	0.98	1.06	ENH4X43*21**	*9MVX100	1.00	1.00
EHD4X42A**	*8MPV075	0.99	1.03	ED*4X36F**	MV12F19**B*	0.96	0.96
EHD4X42A**	*8MPV100	1.00	1.00	ED*4X36J**	MV16J22**B*	0.96	0.96
EHD4X42A**	*8MPV125	1.00	1.00	ED*4X42L**	MV20L24**B*	0.98	0.98
EHD4X42A**	*8MV*0701412**	0.98	1.02	ENH4X42*21**	MV20L24**B*	0.98	0.98
EHD4X42A**	*8MV*0901716**	0.98	0.98	EN(A,D,W)4X36*17**	NOMV106D12*	0.94	1.02
EHD4X42A**	*8MV*1102120**	0.99	0.99	EN(A,D)4X36*21**	NOMV156E19*	0.95	1.03
EHD4X42A**	*8MV*1352422**	0.99	0.99	EHD4X42A**	OLV098A12A	0.98	1.02
EHD4X42A**	*8MX*0451408**	0.98	1.07	ENH4X36*17**	OLV098A12A	0.96	1.03
EHD4X42A**	*8MX*0701716**	0.99	1.03	ED*4X42F**	OLV112A16A	0.97	1.01
EHD4X42A**	*8MX*0902116**	0.99	0.99	ENH4X36*17**	OLV112A16A	0.97	1.05
EHD4X42A**	*8MX*1102120**	1.00	1.00	ENH4X36*17**	OLV154F20A	0.98	1.02
EHD4X42A**	*9MPV050	0.98	1.07	EN(A,D,W)4X36*17**	OMV098J12A	0.96	1.03
EHD4X42A**	*9MPV075	0.98	1.07	EHD4X36A**	OMV112K14A	0.98	1.02
EHD4X42A**	*9MPV100	0.99	1.03	ENH4X42*21**	OMV112K14A	0.97	1.01
EHD4X42A**	*9MPV125	1.00	1.00	EHD4X42A**	-	0.99	1.07
EHD4X42A**	*9MVX040	0.98	1.07	ENH4X36*17**	-	0.96	1.09
EN(A,D)4X36*21**	*8MV*1102120**	0.96	0.99	EN(A,D,W)4X42*21**	NOMV156E19*	0.96	1.00
EN(A,D)4X36*21**	*8MX*0902116**	0.96	1.00	ENH4X42*21**	OLV112A16A	0.98	1.02
EN(A,D)4X36*21**	*8MX*1102120**	0.96	1.00	ENH4X42*21**	OLV154F20A	1.00	1.04
EN(A,D)4X36*21**	*9MPV100	0.97	1.01	ENH4X43*21**	OMV112K14A	1.00	1.04

COOLING Multiplying Factors for other Indoor Combinations

Indoor Model	Furnace Model	CAPACITY (MBh)	Power (AMPS)	Indoor Model	Furnace Model	CAPACITY (MBh)	Power (AMPS)
EN(A,D)4X37*17**	*8MV*0901716**	0.99	0.99	END4X42*17**	NOMV106D12*	0.97	1.00
EN(A,D)4X37*17**	*8MX*0701716**	0.99	1.03	ED*4X42J**	OLV112A16A	0.98	1.02
EN(A,D)4X37*17**	*9MPV050	0.99	1.08	EN(A,D,W)4X42*21**	OMV098J12A	0.97	1.05
EN(A,D)4X37*17**	*9MPV075	1.00	1.04	EHD4X42A**	OMV112K14A	0.99	1.03
EN(A,D)4X37*17**	*9MVX040	0.99	1.08	ENH4X42*21**	-	0.97	1.10
EN(A,D)4X43*24**	*8MV*1352422**	1.00	1.00	EN(A,D)4X36*21**	OLV098A12A	0.96	1.03
EN(A,D)4X43*24**	*9MPV100	1.01	1.05	ED*4X36B**	-	0.96	1.11
EN(A,D)4X43*24**	*9MPV125	1.00	1.00	EMA4X36D**	-	0.96	1.12
EN(A,D,W)4X36*17**	*8MV*0901716**	0.96	0.99	ENH4X36*17**	NOMV106D12*	0.94	1.02
EN(A,D,W)4X36*17**	*8MX*0701716**	0.95	1.03	ED*4X42L**	OLV112A16A	0.98	1.02
EN(A,D,W)4X42*21**	*8MV*1102120**	0.97	1.00	ENH4X36*17**	NOMV156E19*	0.95	1.03
EN(A,D,W)4X42*21**	*8MX*0902116**	0.97	1.01	ENH4X43*21**	OLV112A16A	1.01	1.05
EN(A,D,W)4X42*21**	*8MX*1102120**	0.98	1.02	ENH4X43*21**	OLV154F20A	1.01	1.05
EN(A,D,W)4X42*21**	*9MPV100	0.98	1.02	ED*4X36F**	-	0.96	1.11
END4X42*17**	*8MV*0901716**	0.97	1.01	ENH4X42*21**	NOMV106D12*	0.96	1.04
END4X42*17**	*8MX*0701716**	0.97	1.05	EHD4X36A**	OLV112A16A	0.99	1.03
ENH4X36*17**	*8MPV050	0.94	1.07	ED*4X36B**	MV08B15**B*	0.96	0.99
ENH4X36*17**	*8MPV075	0.96	1.04	ED*4X42F**	MV12F19**B*	0.97	0.97
ENH4X36*17**	*8MPV100	0.97	1.05	ED*4X42J**	MV16J22**B*	0.98	0.98
ENH4X36*17**	*8MPV125	0.97	1.00	EHD4X36A**	MV20L24**B*	0.99	0.99
ENH4X36*17**	*8MV*0701412**	0.95	1.03	ENH4X43*21**	MV20L24**B*	1.00	1.00
ENH4X36*17**	*8MV*0901716**	0.96	0.99	ENH4X43*21**	NOMV106D12*	0.99	1.03
ENH4X36*17**	*8MV*1102120**	0.96	1.03	ENH4X42*21**	NOMV156E19*	0.96	1.00
ENH4X36*17**	*8MV*1352422**	0.96	0.99	EN(A,D)4X37*17**	OLV098A12A	0.99	1.03
ENH4X36*17**	*8MX*0451408**	0.95	1.07	ENH4X42*21**	OLV098A12A	0.97	1.05
ENH4X36*17**	*8MX*0701716**	0.95	1.03	EHD4X42A**	OLV112A16A	0.99	1.03
ENH4X36*17**	*8MX*0902116**	0.96	1.00	ED*4X42L**	OLV154F20A	1.00	1.04
ENH4X36*17**	*8MX*1102120**	0.96	1.00	ED*4X36F**	OMV098J12A	0.96	1.04
ENH4X36*17**	*9MPV050	0.95	1.07	END4X42*17**	OMV098J12A	0.98	1.06
ENH4X36*17**	*9MPV075	0.95	1.07	EN(A,D)4X36*21**	OMV112K14A	0.96	1.04
ENH4X36*17**	*9MPV100	0.96	1.04	ED*4X36J**	-	0.96	1.11
ENH4X36*17**	*9MPV125	0.97	1.05	EN(A,D)4X36*21**	-	0.96	1.09
ENH4X36*17**	*9MVX040	0.94	1.07	ENH4X43*21**	-	1.00	1.08
ENH4X42*21**	*8MPV050	0.96	1.08	EHD4X36A**	MV08B15**B*	0.99	0.99
ENH4X42*21**	*8MPV075	0.97	1.05	EHD4X36A**	MV12F19**B*	0.99	0.99

COOLING Multiplying Factors for other Indoor Combinations

Indoor Model	Furnace Model	CAPACITY (MBh)	Power (AMPS)	Indoor Model	Furnace Model	CAPACITY (MBh)	Power (AMPS)
ENH4X42*21**	*8MPV100	0.98	1.02	EHD4X36A**	MV16J22**B*	0.99	0.99
ENH4X42*21**	*8MPV125	0.98	1.02	EHD4X42A**	MV20L24**B*	0.99	0.99
ENH4X42*21**	*8MV*0701412**	0.96	1.04	ED*4X36F**	NOMV106D12*	0.95	1.03
ENH4X42*21**	*8MV*0901716**	0.97	1.00	ED*4X36J**	NOMV156E19*	0.96	0.99
ENH4X42*21**	*8MV*1102120**	0.97	1.00	ENH4X43*21**	NOMV156E19*	0.99	0.99
ENH4X42*21**	*8MV*1352422**	0.97	1.00	EN(A,D,W)4X36*17**	OLV098A12A	0.96	1.03
ENH4X42*21**	*8MX*0451408**	0.96	1.04	ENH4X43*21**	OLV098A12A	0.99	1.03
ENH4X42*21**	*8MX*0701716**	0.97	1.05	EN(A,D)4X36*21**	OLV112A16A	0.97	1.05
ENH4X42*21**	*8MX*0902116**	0.97	1.01	EHD4X36A**	OLV154F20A	1.01	1.05
ENH4X42*21**	*8MX*1102120**	0.98	1.02	ED*4X42F**	OMV098J12A	0.97	1.05
ENH4X42*21**	*9MPV050	0.96	1.09	ENH4X36*17**	OMV098J12A	0.96	1.03
ENH4X42*21**	*9MPV075	0.97	1.05	EN(A,D)4X37*17**	OMV112K14A	1.00	1.04
ENH4X42*21**	*9MPV100	0.98	1.06	ED*4X42F**	-	0.97	1.13
ENH4X42*21**	*9MPV125	0.98	1.02	EN(A,D)4X37*17**	-	1.00	1.08
ENH4X42*21**	*9MVX040	0.96	1.09	-	-	-	-
ENH4X43*21**	*8MPV050	0.99	1.07	EHD4X42A**	MV08B15**B*	0.99	0.99
ENH4X43*21**	*8MPV075	1.00	1.04	EHD4X42A**	MV12F19**B*	0.99	0.99
ENH4X43*21**	*8MPV100	1.00	1.00	EHD4X42A**	MV16J22**B*	0.99	0.99
ENH4X43*21**	*8MPV125	1.00	1.00	EN(A,D)4X43*24**	MV20L24**B*	1.00	1.00
ENH4X43*21**	*8MV*0701412**	0.99	1.03	ED*4X42F**	NOMV106D12*	-	-
ENH4X43*21**	*8MV*0901716**	0.99	0.99	ED*4X42J**	NOMV156E19*	0.96	1.00
ENH4X43*21**	*8MV*1102120**	0.99	0.99	ED*4X36F**	OLV098A12A	0.96	1.03
ENH4X43*21**	*8MV*1352422**	0.99	0.99	EN(A,D,W)4X42*21**	OLV098A12A	0.97	1.05
ENH4X43*21**	*8MX*0451408**	0.99	1.08	ED*4X36F**	OLV112A16A	0.97	1.05
ENH4X43*21**	*8MX*0701716**	1.00	1.04	EN(A,D)4X43*24**	OLV112A16A	1.01	1.05
ENH4X43*21**	*8MX*0902116**	1.01	1.01	EHD4X42A**	OLV154F20A	1.01	1.05
ENH4X43*21**	*8MX*1102120**	1.00	1.00	EHD4X36A**	OMV098J12A	0.98	1.07
ENH4X43*21**	*9MPV050	0.99	1.08	ENH4X42*21**	OMV098J12A	0.97	1.05
ENH4X43*21**	*9MPV075	0.99	1.08	EN(A,D,W)4X36*17**	OMV112K14A	0.96	1.04
ENH4X43*21**	*9MPV100	1.00	1.04	ED*4X42J**	-	0.97	1.13
ENH4X43*21**	*9MPV125	1.00	1.00	EN(A,D)4X43*24**	-	1.00	1.08
FEA4X36**A*	-	0.96	1.08	ED*4X36F**	*9MVX060	0.96	1.03
FEM4P36**A*	-	0.96	1.03	ED*4X42F**	*9MVX060	0.97	1.05
FEM4P36**A*	-	0.96	1.08	EHD4X36A**	*9MVX060	0.98	1.07
FEM4P42**A*	-	1.00	1.04	EHD4X42A**	*9MVX060	0.98	1.02

COOLING Multiplying Factors for other Indoor Combinations

Indoor Model	Furnace Model	CAPACITY (MBh)	Power (AMPS)	Indoor Model	Furnace Model	CAPACITY (MBh)	Power (AMPS)
FEM4P42**A*	-	0.99	1.07	EN(A,D)4X37*17**	*9MVX060	1.01	1.05
FEM4P48**A*	-	-	-	ENH4X36*17**	*9MVX060	0.96	1.08
FEM4X36****	-	1.00	1.04	ENH4X42*21**	*9MVX060	0.97	1.05
FEM4X42****	-	1.00	1.04	ENH4X43*21**	*9MVX060	1.00	1.04
FS(M,U)4P36**A*	-	0.97	1.05	ED*4X36J**	*9MVX080	0.98	1.02
FS(M,U)4P36**A*	-	0.96	1.09	ED*4X42J**	*9MVX080	0.98	1.02
FS(M,U)4P42**A*	-	0.99	1.05	EHD4X36A**	*9MVX080	1.00	1.04
FS(M,U)4P42**A*	-	0.98	1.11	EHD4X42A**	*9MVX080	1.00	1.04
FS(M,U)4X42****	-	0.98	1.11	EN(A,D)4X36*21**	*9MVX080	0.98	1.02
FSA4X36**A*	-	0.97	1.14	EN(A,D)4X43*24**	*9MVX080	1.01	1.05
FSM4X36****	-	0.98	1.14	EN(A,D,W)4X42*21**	*9MVX080	0.99	1.03
FSU4X36****	-	0.96	1.09	ENH4X36*17**	*9MVX080	0.97	1.05
FVM4X24****	-	0.96	1.00	ENH4X42*21**	*9MVX080	0.98	1.07
FVM4X36****	-	0.97	0.97	ENH4X43*21**	*9MVX080	1.00	1.04
FVM4X48****	-	1.01	1.01	ED*4X42L**	*9MVX100	0.98	1.02
FVM4X60****	-	1.01	1.01	EHD4X36A**	*9MVX100	0.99	1.03
FXM4X42**A*	-	1.00	1.00	EHD4X42A**	*9MVX100	1.00	1.00
FXM4X48**A*	-	-	-	EN(A,D)4X43*24**	*9MVX100	1.00	1.00
<b>NXH542</b>							
*FXM4X42**A*	-	1.00	1.00	EHD4X48A**	*9MA*0802120A**	1.00	1.02
EA*4X42*21A*	*8MX*0902116**	0.99	1.01	ENH4X48*21**	*9MA*1202422A**	1.00	1.00
EA*4X42*21A*	*8MX*1102120**	0.99	1.01	ED*4X42F**	*9MVX060	0.98	1.06
EA*4X42*21A*	*8MV*1102120**	0.99	1.01	ED*4X48J**	*9MX*1002116A**	0.99	1.03
EA*4X42*21A*	*9MX*0601714A**	0.98	1.06	ED*4X48L**	*9MV*1002116A**	1.00	1.04
EA*4X42*21A*	*9MX*0801716A**	0.99	1.05	EA*4X48*24A*	*9MA*1002120A**	0.99	1.03
EA*4X42*21A*	*9MX*0802120A**	0.99	1.03	ENH4X43*21**	*9MA*1002120A**	1.01	1.01
EA*4X42*21A*	*9MX*1002120A**	0.99	1.01	EHD4X42A**	OLV112A16A	1.01	1.05
EA*4X42*21A*	*9MV*0601714A**	0.98	1.07	EHD4X42A**	OMV112K14A	1.00	1.04
EA*4X42*21A*	*9MV*0801716A**	0.98	1.06	EA*4X48*21A*	-	1.01	1.10
EA*4X42*21A*	*9MV*0802120A**	0.99	1.03	ED*4X42L**	MV20L24**B*	1.00	1.00
EA*4X42*21A*	*9MV*1002120A**	0.99	1.01	ED*4X48J**	*9MPV100	1.01	1.05
EA*4X42*21A*	*9MA*0601714A**	0.96	1.06	EHD4X48A**	*9MPV075	1.00	1.09
EA*4X42*21A*	*9MA*0801714A**	0.98	1.03	EN(A,D)4X48*24**	*9MPV125	1.01	1.01

COOLING Multiplying Factors for other Indoor Combinations

Indoor Model	Furnace Model	CAPACITY (MBh)	Power (AMPS)	Indoor Model	Furnace Model	CAPACITY (MBh)	Power (AMPS)
EA*4X42*21A*	*9MA*0802120A**	0.98	1.02	ENH4X48*21**	-	1.01	1.10
EA*4X42*24A*	*8MX*1352420**	0.99	1.01	EN(A,D)4X43*24**	*9MVX080	1.01	1.01
EA*4X42*24A*	*8MV*1352422**	0.99	1.01	ENH4X48*21**	*9MX*1002116A**	1.00	1.04
EA*4X42*24A*	*9MX*1202422A**	1.00	1.04	ENH4X48*21**	OLV112A16A	1.01	1.05
EA*4X42*24A*	*9MV*1202422A**	0.99	1.03	EHD4X42A**	*8MPV125	1.00	1.04
EA*4X48*17A*	*8MX*0701716**	1.00	1.07	ED*4X48L**	*9MA*1202422A**	0.99	1.03
EA*4X48*17A*	*8MV*0901716**	1.00	1.02	ENH4X48*21**	*9MVX100	1.01	1.01
EA*4X48*17A*	*9MX*0601714A**	1.00	1.06	EHD4X42A**	*9MV*1002116A**	1.01	1.05
EA*4X48*17A*	*9MX*0801716A**	1.01	1.05	ED*4X42J**	*9MA*1002120A**	0.98	1.03
EA*4X48*17A*	*9MV*0601714A**	1.00	1.06	EHD4X48A**	OMV112K14A	1.01	1.05
EA*4X48*17A*	*9MV*0801716A**	1.00	1.04	EA*4X48*24A*	-	1.01	1.10
EA*4X48*17A*	*9MA*0601714A**	0.99	1.05	EHD4X48A**	*9MPV100	1.01	1.01
EA*4X48*17A*	*9MA*0801714A**	1.00	1.04	EN(A,D,W)4X42*21**	-	0.99	1.07
EA*4X48*21A*	*8MX*0902116**	1.00	1.02	ED*4X42J**	NOMV156E19*	0.98	1.02
EA*4X48*21A*	*8MX*1102120**	1.00	1.00	ED*4X48F**	*9MVX060	1.00	1.04
EA*4X48*21A*	*8MV*1102120**	1.00	1.02	ED*4X48J**	*9MX*1002116A**	0.99	1.03
EA*4X48*21A*	*9MX*0601714A**	1.00	1.06	EHD4X48A**	*9MV*1002116A**	1.01	1.05
EA*4X48*21A*	*9MX*0801716A**	1.00	1.06	ED*4X42L**	*9MA*1002120A**	0.98	1.03
EA*4X48*21A*	*9MX*0802120A**	1.00	1.02	ENH4X48*21**	*9MA*1002120A**	1.00	1.04
EA*4X48*21A*	*9MX*1002120A**	1.00	1.02	EHD4X48A**	OLV112A16A	1.01	1.05
EA*4X48*21A*	*9MV*0601714A**	0.99	1.07	EN(A,D,W)4X42*21**	OMV112K14A	0.98	1.02
EA*4X48*21A*	*9MV*0801716A**	0.99	1.05	ED*4X42F**	-	0.98	1.06
EA*4X48*21A*	*9MV*0802120A**	1.00	1.02	ED*4X48F**	-	1.01	1.10
EA*4X48*21A*	*9MV*1002120A**	1.00	1.02	ED*4X48J**	MV16J22**B*	1.01	1.01
EA*4X48*21A*	*9MA*0601714A**	0.99	1.05	EHD4X48A**	*9MPV125	1.01	1.01
EA*4X48*21A*	*9MA*0801714A**	0.99	1.05	EN(A,D,W)4X42*21**	*9MPV100	0.99	1.03
EA*4X48*21A*	*9MA*0802120A**	0.99	1.01	ENH4X48*21**	*9MPV100	1.01	1.01
EA*4X48*24A*	*8MX*1352420**	1.01	1.01	EN(A,D)4X48*24**	*9MVX080	1.01	1.01
EA*4X48*24A*	*8MV*1352422**	1.00	1.00	EA*4X42*21A*	*9MV*1002116A**	0.99	1.05
EA*4X48*24A*	*9MX*1202422A**	1.01	1.01	ED*4X42L**	OLV154F20A	1.01	1.05
EA*4X48*24A*	*9MV*1202422A**	1.00	1.00	EHD4X42A**	*9MPV075	0.99	1.07
ED*4X42F**	*9MV*1202422A**	0.98	1.07	EN(A,D)4X43*24**	*9MV*1002116A**	1.01	1.01
ED*4X42F**	*9MX*0601714A**	0.99	1.07	ED*4X48J**	*9MA*1002120A**	0.99	1.03
ED*4X42F**	*9MV*0601714A**	0.98	1.07	EN(A,D,W)4X48*21**	OMV112K14A	1.00	1.04
ED*4X42F**	*9MV*0801716A**	0.98	1.06	ED*4X42F**	*8MPV075	0.99	1.07

COOLING Multiplying Factors for other Indoor Combinations

Indoor Model	Furnace Model	CAPACITY (MBh)	Power (AMPS)	Indoor Model	Furnace Model	CAPACITY (MBh)	Power (AMPS)
ED*4X42F**	*9MA*0601714A**	0.96	1.06	EHD4X48A**	MV12F19**B*	1.01	1.01
ED*4X42F**	*9MA*0801714A**	0.98	1.06	EN(A,D,W)4X42*21**	*9MAC0602120A**	0.98	1.04
ED*4X42J**	*8MX*0902116**	0.99	1.03	ED*4X48J**	NOMV156E19*	1.00	1.04
ED*4X42J**	*8MX*1102120**	0.99	0.99	EHD4X42A**	*9MVX060	0.99	1.07
ED*4X42J**	*8MV*1102120**	0.99	1.03	ED*4X48L**	*9MX*1002116A**	1.00	1.04
ED*4X42J**	*9MV*1202422A**	0.99	1.03	EHD4X42A**	*9MPV100	0.99	1.03
ED*4X42L**	*8MX*1352420**	0.99	1.03	EN(A,D,W)4X42*21**	*9MVX080	0.99	1.03
ED*4X42L**	*8MV*1352422**	0.99	0.99	EA*4X42*24A*	*9MV*1002116A**	0.99	1.05
ED*4X42L**	*9MX*1202422A**	1.00	1.04	ED*4X48L**	OLV154F20A	1.01	1.01
ED*4X42L**	*9MV*1202422A**	0.99	1.03	EHD4X42A**	*9MPV125	0.99	1.03
ED*4X48F**	*8MX*0701716**	1.00	1.04	EHD4X42A**	*9MA*1202422A**	1.00	1.00
ED*4X48F**	*8MV*0901716**	1.00	1.00	EA*4X42*21A*	*9MX*1002116A**	0.98	1.03
ED*4X48F**	*9MX*0601714A**	1.00	1.06	EN(A,D)4X48*24**	*9MV*1002116A**	1.01	1.05
ED*4X48F**	*9MX*0801716A**	1.01	1.05	ED*4X48J**	*9MA*1002120A**	0.99	1.03
ED*4X48F**	*9MV*0601714A**	1.00	1.06	END4X42*17**	OMV112K14A	0.99	1.03
ED*4X48F**	*9MV*0801716A**	1.00	1.04	ED*4X42F**	*9MPV075	0.98	1.06
ED*4X48F**	*9MA*0601714A**	0.99	1.05	EHD4X48A**	MV16J22**B*	1.01	1.01
ED*4X48F**	*9MA*0801714A**	1.00	1.04	EN(A,D,W)4X48*21**	-	1.01	1.10
ED*4X48J**	*8MX*0902116**	1.00	1.00	EHD4X42A**	NOMV156E19*	1.00	1.00
ED*4X48J**	*8MX*1102120**	1.00	1.00	EHD4X48A**	*9MVX060	1.00	1.04
ED*4X48J**	*8MV*1102120**	1.00	1.00	EHD4X42A**	*9MX*1002116A**	1.00	1.04
ED*4X48J**	*9MX*1202422A**	1.01	1.05	EHD4X42A**	OLV154F20A	1.01	1.01
ED*4X48L**	*9MV*1202422A**	1.00	1.04	EHD4X42A**	MV12F19**B*	1.00	1.00
ED*4X48L**	*8MX*1352420**	1.01	1.01	EN(A,D,W)4X48*21**	*9MVX080	1.01	1.01
ED*4X48L**	*8MV*1352422**	1.00	1.00	EA*4X48*21A*	*9MV*1002116A**	1.00	1.04
ED*4X48L**	*9MX*1202422A**	1.01	1.01	EHD4X48A**	OLV154F20A	1.01	1.01
ED*4X48L**	*9MV*1202422A**	1.00	1.00	EHD4X42A**	MV16J22**B*	0.99	0.99
EHD4X42A**	*8MX*0701716**	0.99	1.07	EHD4X48A**	*9MA*1202422A**	1.00	1.00
EHD4X42A**	*8MX*0902116**	1.00	1.00	EHD4X48A**	NOMV156E19*	1.00	1.00
EHD4X42A**	*8MX*1102120**	1.00	1.00	EN(A,D,W)4X42*21**	*9MVX060	0.98	1.06
EHD4X42A**	*8MX*1352420**	1.00	1.00	ENH4X42*21**	*9MVX080	0.99	1.03
EHD4X42A**	*8MV*0701412**	0.99	1.03	EHD4X48A**	*9MPV100	1.01	1.01
EHD4X42A**	*8MV*0901716**	1.00	1.00	EA*4X42*24A*	*9MX*1002116A**	0.98	1.03
EHD4X42A**	*8MV*1102120**	1.00	1.00	EHD4X48A**	*9MX*1002116A**	1.00	1.04
EHD4X42A**	*8MV*1352422**	1.00	1.00	EA*4X48*24A*	*9MV*1002116A**	1.00	1.04

COOLING Multiplying Factors for other Indoor Combinations

Indoor Model	Furnace Model	CAPACITY (MBh)	Power (AMPS)	Indoor Model	Furnace Model	CAPACITY (MBh)	Power (AMPS)
EHD4X42A**	*9MX*0601714A**	1.00	1.06	EN(A,D,W)4X42*21**	*9MV*1002116A**	0.99	1.05
EHD4X42A**	*9MX*0801716A**	1.01	1.05	ED*4X48L**	*9MA*1002120A**	0.99	1.03
EHD4X42A**	*9MX*0802120A**	1.01	1.04	ED*4X42F**	OLV112A16A	0.99	1.07
EHD4X42A**	*9MX*1002120A**	1.00	1.00	EN(A,D)4X43*24**	OLV112A16A	1.01	1.01
EHD4X42A**	*9MX*1202422A**	1.01	1.01	EN(A,D)4X43*24**	OLV154F20A	1.01	1.01
EHD4X42A**	*9MV*0601714A**	1.00	1.06	ENH4X42*21**	OMV112K14A	0.98	1.02
EHD4X42A**	*9MV*0801716A**	1.00	1.04	ED*4X42F**	MV12F19**B*	0.99	0.99
EHD4X42A**	*9MV*0802120A**	1.00	1.02	ED*4X48F**	*8MPV075	1.01	1.05
EHD4X42A**	*9MV*1002120A**	1.00	1.00	ED*4X48L**	-	1.01	1.10
EHD4X42A**	*9MA*0601714A**	0.99	1.05	EHD4X48A**	MV20L24**B*	1.01	1.01
EHD4X42A**	*9MA*0801714A**	0.99	1.03	EN(A,D,W)4X48*21**	*9MPV100	1.01	1.01
EHD4X42A**	*9MA*0802120A**	1.00	1.02	ENH4X48*21**	*9MPV125	1.01	1.01
EHD4X48A**	*8MX*0701716**	1.00	1.04	EN(A,D)4X43*24**	*9MA*1202422A**	1.01	1.01
EHD4X48A**	*8MX*0902116**	1.01	1.01	EN(A,D,W)4X42*21**	NOMV156E19*	0.98	1.02
EHD4X48A**	*8MX*1102120**	1.01	1.01	END4X42*17**	*9MVX060	0.99	1.07
EHD4X48A**	*8MX*1352420**	1.01	1.01	ENH4X43*21**	*9MVX080	1.01	1.01
EHD4X48A**	*8MV*0701412**	1.00	1.04	EN(A,D)4X43*24**	*9MVX100	1.01	1.01
EHD4X48A**	*8MV*0901716**	1.00	1.00	EA*4X48*21A*	*9MX*1002116A**	0.99	1.03
EHD4X48A**	*8MV*1102120**	1.00	1.00	EN(A,D)4X43*24**	*9MX*1002116A**	1.01	1.01
EHD4X48A**	*8MV*1352422**	1.01	1.01	ED*4X42F**	*9MV*1002116A**	0.98	1.03
EHD4X48A**	*9MX*0601714A**	1.00	1.04	EN(A,D,W)4X48*21**	*9MV*1002116A**	1.01	1.05
EHD4X48A**	*9MX*0801716A**	1.01	1.05	EHD4X42A**	*9MA*1002120A**	1.00	1.04
EHD4X48A**	*9MX*0802120A**	1.01	1.01	ED*4X42J**	OLV112A16A	0.99	1.07
EHD4X48A**	*9MX*1002120A**	1.01	1.01	EN(A,D)4X48*24**	OLV112A16A	1.01	1.05
EHD4X48A**	*9MX*1202422A**	1.01	1.01	EN(A,D)4X48*24**	OLV154F20A	1.01	1.01
EHD4X48A**	*9MV*0601714A**	1.00	1.06	ENH4X43*21**	OMV112K14A	1.01	1.01
EHD4X48A**	*9MV*0801716A**	1.00	1.04	ED*4X42J**	-	0.99	1.07
EHD4X48A**	*9MV*0802120A**	1.01	1.01	ED*4X48F**	*9MPV075	1.00	1.09
EHD4X48A**	*9MV*1002120A**	1.01	1.01	ED*4X48L**	*9MPV125	1.01	1.01
EHD4X48A**	*9MV*1202422A**	1.01	1.01	EHD4X42A**	MV20L24**B*	1.00	1.00
EHD4X48A**	*9MA*0601714A**	0.99	1.05	EHD4X48A**	*9MAC0602120A**	1.00	1.02
EHD4X48A**	*9MA*0801714A**	1.00	1.04	EN(A,D,W)4X48*21**	*9MAC0602120A**	0.99	1.01
EN(A,D)4X43*24**	*8MX*1102120**	1.01	0.97	ENH4X42*21**	*9MVX060	0.98	1.06
EN(A,D)4X43*24**	*8MX*1352420**	1.01	0.97	ENH4X48*21**	*9MVX080	1.01	1.01
EN(A,D)4X43*24**	*8MV*1102120**	1.01	1.01	EN(A,D)4X48*24**	*9MX*1002116A**	1.00	1.04



COOLING Multiplying Factors for other Indoor Combinations

Indoor Model	Furnace Model	CAPACITY (MBh)	Power (AMPS)	Indoor Model	Furnace Model	CAPACITY (MBh)	Power (AMPS)
EN(A,D)4X43*24**	*8MV*1352422**	1.01	0.97	ED*4X42J**	*9MV*1002116A**	0.99	1.05
EN(A,D)4X43*24**	*9MX*1202422A**	1.01	1.00	ENH4X42*21**	OLV154F20A	1.01	1.05
EN(A,D)4X43*24**	*9MV*1202422A**	1.01	1.00	EHD4X42A**	*9MAC0602120A**	0.99	1.03
EN(A,D)4X48*24**	*8MX*1352420**	1.01	1.01	ED*4X42L**	*9MVX100	0.99	1.03
EN(A,D)4X48*24**	*8MV*1352422**	1.00	1.00	ED*4X42L**	*9MV*1002116A**	0.99	1.05
EN(A,D)4X48*24**	*9MX*1202422A**	1.01	1.01	ENH4X43*21**	OLV154F20A	1.01	1.01
EN(A,D)4X48*24**	*9MV*1202422A**	1.00	1.00	EHD4X48A**	-	1.01	1.10
EN(A,D,W)4X42*21**	*8MX*0902116**	0.99	1.03	EN(A,D,W)4X48*21**	NOMV156E19*	1.00	1.00
EN(A,D,W)4X42*21**	*8MX*1102120**	0.99	1.03	ED*4X42J**	*9MVX080	1.00	1.04
EN(A,D,W)4X42*21**	*8MV*1102120**	0.99	1.03	EN(A,D,W)4X42*21**	*9MX*1002116A**	0.98	1.03
EN(A,D,W)4X42*21**	*9MX*0601714A**	0.98	1.07	ENH4X42*21**	*9MV*1002116A**	0.99	1.05
EN(A,D,W)4X42*21**	*9MX*0801716A**	0.99	1.07	EHD4X48A**	*9MA*1002120A**	1.00	1.04
EN(A,D,W)4X42*21**	*9MX*0802120A**	0.99	1.03	ED*4X42L**	OLV112A16A	0.99	1.03
EN(A,D,W)4X42*21**	*9MX*1002120A**	0.99	1.03	EN(A,D,W)4X42*21**	OLV112A16A	0.99	1.07
EN(A,D,W)4X42*21**	*9MV*0601714A**	0.98	1.07	ENH4X48*21**	OMV112K14A	1.00	1.04
EN(A,D,W)4X42*21**	*9MV*0801716A**	0.98	1.06	ED*4X42J**	*8MPV100	1.00	1.04
EN(A,D,W)4X42*21**	*9MV*0802120A**	0.99	1.03	ED*4X48F**	MV12F19**B*	1.01	1.01
EN(A,D,W)4X42*21**	*9MV*1002120A**	0.98	1.02	ED*4X48L**	MV20L24**B*	1.01	1.01
EN(A,D,W)4X42*21**	*9MA*0601714A**	0.96	1.06	EMA4X48D**	-	1.00	1.09
EN(A,D,W)4X42*21**	*9MA*0801714A**	0.98	1.06	END4X42*17**	-	1.00	1.09
EN(A,D,W)4X48*21**	*8MX*0902116**	1.01	1.01	ENH4X42*21**	NOMV156E19*	0.98	1.02
EN(A,D,W)4X48*21**	*8MX*1102120**	1.01	1.01	ED*4X48J**	*9MVX080	1.01	1.05
EN(A,D,W)4X48*21**	*8MV*1102120**	1.00	1.00	EN(A,D,W)4X48*21**	*9MX*1002116A**	1.00	1.04
EN(A,D,W)4X48*21**	*9MX*0601714A**	1.00	1.06	ENH4X43*21**	*9MV*1002116A**	1.00	1.00
EN(A,D,W)4X48*21**	*9MX*0801716A**	1.00	1.04	EN(A,D)4X43*24**	*9MA*1002120A**	1.01	1.01
EN(A,D,W)4X48*21**	*9MX*0802120A**	1.01	1.04	ED*4X48F**	OLV112A16A	1.01	1.05
EN(A,D,W)4X48*21**	*9MX*1002120A**	1.01	1.01	EN(A,D,W)4X48*21**	OLV112A16A	1.01	1.05
EN(A,D,W)4X48*21**	*9MV*0601714A**	1.00	1.06	EA*4X42*21A*	*9MAC0602120A**	0.98	1.04
EN(A,D,W)4X48*21**	*9MV*0801716A**	1.00	1.04	ED*4X42J**	*8MPV125	1.00	1.04
EN(A,D,W)4X48*21**	*9MV*0802120A**	1.00	1.02	ED*4X48J**	-	1.01	1.10
EN(A,D,W)4X48*21**	*9MV*1002120A**	1.00	1.00	EHD4X42A**	-	0.99	1.07
EN(A,D,W)4X48*21**	*9MA*0601714A**	0.99	1.05	EN(A,D)4X43*24**	-	1.01	1.05
EN(A,D,W)4X48*21**	*9MA*0801714A**	0.99	1.03	ENH4X42*21**	-	0.99	1.07
END4X42*17**	*8MX*0701716**	0.99	1.07	EN(A,D)4X48*24**	*9MA*1202422A**	1.00	1.00
END4X42*17**	*8MV*0901716**	0.99	1.03	EA*4X48*24A*	*9MX*1002116A**	1.00	1.04

COOLING Multiplying Factors for other Indoor Combinations

Indoor Model	Furnace Model	CAPACITY (MBh)	Power (AMPS)	Indoor Model	Furnace Model	CAPACITY (MBh)	Power (AMPS)
END4X42*17**	*9MX*0601714A**	0.99	1.07	ENH4X48*21**	*9MV*1002116A**	1.01	1.05
END4X42*17**	*9MX*0801716A**	0.99	1.05	EN(A,D)4X48*24**	*9MA*1002120A**	1.00	1.04
END4X42*17**	*9MV*0601714A**	0.99	1.07	EA*4X42*21A*	-	0.99	1.09
END4X42*17**	*9MV*0801716A**	0.99	1.05	ED*4X42J**	*9MPV100	0.99	1.03
END4X42*17**	*9MA*0601714A**	0.98	1.06	EN(A,D)4X43*24**	*9MPV100	1.01	1.01
END4X42*17**	*9MA*0801714A**	0.98	1.03	ENH4X42*21**	*9MPV100	0.99	1.03
ENH4X42*21**	*8MX*0701716**	0.98	1.06	ENH4X42*21**	*9MA*1202422A**	0.98	1.02
ENH4X42*21**	*8MX*0902116**	0.99	1.03	ENH4X43*21**	NOMV156E19*	1.01	1.01
ENH4X42*21**	*8MX*1102120**	0.99	1.03	EHD4X42A**	*9MVX080	1.00	1.04
ENH4X42*21**	*8MX*1352420**	0.99	1.03	ED*4X48L**	*9MVX100	1.01	1.01
ENH4X42*21**	*8MV*0701412**	0.98	1.03	EN(A,D)4X48*24**	*9MVX100	1.01	1.01
ENH4X42*21**	*8MV*0901716**	0.99	1.03	ED*4X42J**	*9MX*1002116A**	0.98	1.03
ENH4X42*21**	*8MV*1102120**	0.99	1.03	ENH4X42*21**	*9MX*1002116A**	0.98	1.03
ENH4X42*21**	*8MV*1352422**	0.99	1.03	ED*4X48F**	*9MV*1002116A**	1.01	1.05
ENH4X42*21**	*9MX*0601714A**	0.98	1.07	EA*4X42*21A*	*9MA*1002120A**	0.98	1.03
ENH4X42*21**	*9MX*0801716A**	0.99	1.07	EN(A,D,W)4X42*21**	*9MA*1002120A**	0.98	1.03
ENH4X42*21**	*9MX*0802120A**	0.99	1.03	ED*4X48J**	OLV112A16A	1.00	1.04
ENH4X42*21**	*9MX*1002120A**	0.99	1.03	ENH4X42*21**	OLV112A16A	0.99	1.07
ENH4X42*21**	*9MX*1202422A**	0.99	1.03	ENH4X48*21**	OLV154F20A	1.01	1.01
ENH4X42*21**	*9MV*0601714A**	0.98	1.07	EA*4X42*24A*	-	0.99	1.09
ENH4X42*21**	*9MV*0801716A**	0.98	1.06	ED*4X42J**	MV16J22**B*	0.99	0.99
ENH4X42*21**	*9MV*0802120A**	0.99	1.03	ED*4X48J**	*8MPV100	1.01	1.01
ENH4X42*21**	*9MV*1002120A**	0.98	1.02	EHD4X42A**	*8MPV075	1.00	1.04
ENH4X42*21**	*9MV*1202422A**	0.99	1.03	EHD4X48A**	*8MPV075	1.01	1.05
ENH4X42*21**	*9MA*0601714A**	0.96	1.06	EN(A,D)4X43*24**	*9MPV125	1.01	1.01
ENH4X42*21**	*9MA*0801714A**	0.98	1.06	ENH4X42*21**	*9MAC0602120A**	0.98	1.04
ENH4X43*21**	*9MX*0601714A**	1.01	1.05	EA*4X42*24A*	*9MA*1002120A**	0.98	1.03
ENH4X43*21**	*9MX*0801716A**	1.01	1.05	EN(A,D,W)4X48*21**	*9MA*1002120A**	1.00	1.04
ENH4X43*21**	*9MX*1202422A**	1.01	1.01	ED*4X42F**	OMV112K14A	0.98	1.02
ENH4X43*21**	*9MV*0601714A**	1.00	1.04	EA*4X48*17A*	-	1.01	1.08
ENH4X43*21**	*9MV*0801716A**	1.00	1.04	ED*4X42L**	-	0.99	1.07
ENH4X43*21**	*9MV*1202422A**	1.01	1.01	EHD4X48A**	*8MPV100	1.01	1.01
ENH4X43*21**	*9MA*0601714A**	1.00	1.04	EN(A,D)4X48*24**	-	1.01	1.10
ENH4X43*21**	*9MA*0801714A**	1.00	1.04	ENH4X43*21**	*9MPV100	1.01	1.01
ENH4X48*21**	*8MX*0701716**	1.00	1.04	ENH4X43*21**	*9MA*1202422A**	1.01	1.01

COOLING Multiplying Factors for other Indoor Combinations

Indoor Model	Furnace Model	CAPACITY (MBh)	Power (AMPS)	Indoor Model	Furnace Model	CAPACITY (MBh)	Power (AMPS)
ENH4X48*21**	*8MX*0902116**	1.01	1.01	ENH4X48*21**	NOMV156E19*	1.00	1.00
ENH4X48*21**	*8MX*1102120**	1.01	1.01	EHD4X48A**	*9MVX080	1.01	1.05
ENH4X48*21**	*8MX*1352420**	1.01	1.01	EHD4X42A**	*9MVX100	0.99	1.03
ENH4X48*21**	*8MV*0701412**	1.00	1.04	ENH4X43*21**	*9MVX100	1.01	1.01
ENH4X48*21**	*8MV*0901716**	1.00	1.00	ED*4X42L**	*9MX*1002116A**	0.98	1.03
ENH4X48*21**	*8MV*1102120**	1.00	1.00	ENH4X43*21**	*9MX*1002116A**	1.01	1.01
ENH4X48*21**	*8MV*1352422**	1.00	1.00	ED*4X48J**	*9MV*1002116A**	1.00	1.04
ENH4X48*21**	*9MX*0601714A**	1.00	1.06	EA*4X48*21A*	*9MA*1002120A**	0.99	1.03
ENH4X48*21**	*9MX*0801716A**	1.00	1.04	ENH4X42*21**	*9MA*1002120A**	0.98	1.03
ENH4X48*21**	*9MX*0802120A**	1.01	1.04	ED*4X48L**	OLV112A16A	1.00	1.04
ENH4X48*21**	*9MX*1002120A**	1.01	1.01	ENH4X43*21**	OLV112A16A	1.01	1.05
ENH4X48*21**	*9MX*1202422A**	1.01	1.01	ED*4X48F**	OMV112K14A	1.00	1.04
ENH4X48*21**	*9MV*0601714A**	1.00	1.06	EA*4X48*21A*	*9MAC0602120A**	0.99	1.03
ENH4X48*21**	*9MV*0801716A**	1.00	1.04	ED*4X42L**	*9MPV125	0.99	1.03
ENH4X48*21**	*9MV*0802120A**	1.00	1.02	ED*4X48J**	*8MPV125	1.01	1.01
ENH4X48*21**	*9MV*1002120A**	1.00	1.00	EHD4X42A**	*8MPV100	1.00	1.04
ENH4X48*21**	*9MV*1202422A**	1.00	1.00	EHD4X48A**	*8MPV125	1.01	1.01
ENH4X48*21**	*9MA*0601714A**	0.99	1.05	EN(A,D)4X48*24**	*9MPV100	1.01	1.01
ENH4X48*21**	*9MA*0801714A**	0.99	1.03	ENH4X43*21**	*9MPV125	1.01	1.01
FEM4P42**A*	-	1.01	1.05	EN(A,D,W)4X42*21**	*9MA*0802120A**	0.98	1.02
FEM4P42**A*	-	1.01	1.05	EN(A,D,W)4X48*21**	*9MA*0802120A**	1.00	1.02
FEM4P48**A*	-	1.01	1.01	ENH4X42*21**	*9MA*0802120A**	0.98	1.02
FEM4P48**A*	-	1.01	1.05	ENH4X48*21**	*9MA*0802120A**	1.00	1.02
FEM4X42****	-	1.01	1.05	EA*4X42*21A*	*9MA*1002122A**	0.99	1.01
FEM4X48****	-	1.01	1.01	EA*4X48*21A*	*9MA*1002122A**	1.00	1.02
FS(M,U)4P42**A*	-	1.01	1.05	EHD4X42A**	*9MA*1002122A**	1.01	1.01
FS(M,U)4P42**A*	-	1.01	1.05	EHD4X48A**	*9MA*1002122A**	1.01	1.01
FS(M,U)4P48**A*	-	1.01	1.05	EN(A,D,W)4X42*21**	*9MA*1002122A**	0.99	1.03
FS(M,U)4P48**A*	-	1.01	1.05	EN(A,D,W)4X48*21**	*9MA*1002122A**	1.00	1.00
FS(M,U)4X42****	-	1.00	1.09	ENH4X42*21**	*9MA*1002122A**	0.99	1.03
FS(M,U)4X48****	-	1.01	1.10	ENH4X48*21**	*9MA*1002122A**	1.00	1.00
FVM4X36****	-	0.99	1.03	EA*4X42*24A*	*9MA*1202422A**	0.98	1.02
FVM4X48****	-	1.01	1.01	EA*4X48*24A*	*9MA*1202422A**	0.99	1.03
FVM4X60****	-	1.01	0.97	ED*4X42L**	*9MA*1202422A**	0.98	1.02
FXM4X48**A*	-	1.01	0.97	ED*4X48J**	*9MA*1202422A**	0.99	1.03

COOLING Multiplying Factors for other Indoor Combinations

Indoor Model	Furnace Model	CAPACITY (MBh)	Power (AMPS)	Indoor Model	Furnace Model	CAPACITY (MBh)	Power (AMPS)
-	-	-	-	ENH4X48*21**	*9MAC0602120A**	0.99	1.01
Indoor Model	Furnace Model	CAPACITY (MBh)	Power (AMPS)	Indoor Model	Furnace Model	CAPACITY (MBh)	Power (AMPS)
<b>NXH548</b>							
*FXM4X48**A*	-	1.00	1.00	EHD4X48A**	*9MA*1202422A**	0.96	1.01
EA*4X48*17A*	*8MV*0901716**	0.96	1.02	EHD4X48A**	*9MX*1002116A**	0.96	1.04
EA*4X48*17A*	*9MX*0801716A**	0.95	1.04	EA*4X60*24A*	*9MA*1002120A**	0.96	1.01
EA*4X48*17A*	*9MV*0801716A**	0.95	1.04	ED*4X48F**	-	0.96	1.04
EA*4X48*21A*	*8MX*0902116**	0.96	1.02	ENH4X61*24**	NOMV156E19*	0.97	1.01
EA*4X48*21A*	*8MX*1102120**	0.95	0.99	ENH4X60*24**	*9MVX080	0.98	1.02
EA*4X48*21A*	*8MV*1102120**	0.95	1.01	ENH4X60*24**	*9MX*1002116A**	0.97	1.03
EA*4X48*21A*	*9MX*0801716A**	0.95	1.06	ED*4X48J**	*9MA*1002120A**	0.94	1.02
EA*4X48*21A*	*9MX*0802120A**	0.95	1.01	EN(A,D)4X48*24**	*9MA*1002120A**	0.95	1.03
EA*4X48*21A*	*9MX*1002120A**	0.95	1.01	ENH4X61*24**	*9MA*1002120A**	0.97	1.03
EA*4X48*21A*	*9MV*0801716A**	0.95	1.06	ED*4X48J**	-	0.96	1.04
EA*4X48*21A*	*9MV*0802120A**	0.95	1.01	ED*4X60J**	*8MPV100	0.98	1.02
EA*4X48*21A*	*9MV*1002120A**	0.95	1.01	ED*4X60L**	MV20L24**B*	0.98	0.98
EA*4X48*21A*	*9MA*0802120A**	0.95	1.01	EN(A,D)4X48*24**	*9MPV125	0.96	1.00
EA*4X48*21A*	*9MA*1002122A**	0.95	1.01	EN(A,D,W)4X48*21**	*9MAC0602120A**	0.94	1.02
EA*4X48*24A*	*8MX*1352420**	0.96	1.02	ENH4X60*24**	*9MVX100	0.98	1.02
EA*4X48*24A*	*8MV*1352422**	0.96	1.00	EHD4X48A**	*9MV*1002116A**	0.96	1.04
EA*4X48*24A*	*9MX*1202422A**	0.96	1.01	EHD4X60A**	OLV154F20A	1.00	1.04
EA*4X48*24A*	*9MV*1202422A**	0.96	1.01	EHD4X48A**	MV16J22**B*	0.96	0.96
EA*4X48*24A*	*9MA*1202422A**	0.95	1.00	ENH4X48*21**	*9MPV125	0.96	1.00
EA*4X60*21A*	*8MX*0902116**	0.98	1.02	ED*4X48J**	*9MVX080	0.96	1.04
EA*4X60*21A*	*8MX*1102120**	0.98	1.00	ENH4X61*24**	*9MVX080	0.98	1.02
EA*4X60*21A*	*8MV*1102120**	0.97	1.01	ENH4X61*24**	*9MX*1002116A**	0.97	1.03
EA*4X60*21A*	*9MX*0801716A**	0.97	1.06	ED*4X48J**	*9MA*1002120A**	0.94	1.02
EA*4X60*21A*	*9MX*0802120A**	0.98	1.02	EN(A,D)4X61*24**	*9MA*1002120A**	0.98	1.02
EA*4X60*21A*	*9MX*1002120A**	0.97	1.01	EHD4X60A**	OLV112A16A	0.98	1.06
EA*4X60*21A*	*9MV*0801716A**	0.97	1.06	ED*4X48J**	*8MPV100	0.96	1.01
EA*4X60*21A*	*9MV*0802120A**	0.97	1.01	ED*4X60J**	*8MPV125	0.98	1.02
EA*4X60*21A*	*9MV*1002120A**	0.97	1.01	EHD4X48A**	-	0.96	1.04
EA*4X60*21A*	*9MA*0802120A**	0.96	1.00	EN(A,D)4X61*24**	-	0.99	1.08
EA*4X60*21A*	*9MA*1002122A**	0.97	0.99	EN(A,D,W)4X60*24**	-	0.98	1.06

COOLING Multiplying Factors for other Indoor Combinations

Indoor Model	Furnace Model	CAPACITY (MBh)	Power (AMPS)	Indoor Model	Furnace Model	CAPACITY (MBh)	Power (AMPS)
EA*4X60*24A*	*8MX*1352420**	0.98	1.02	ENH4X61*24**	*9MVX100	0.98	1.02
EA*4X60*24A*	*8MV*1352422**	0.97	0.99	EHD4X60A**	*9MV*1002116A**	0.98	1.04
EA*4X60*24A*	*9MX*1202422A**	0.98	1.02	EN(A,D)4X48*24**	OLV154F20A	0.97	1.05
EA*4X60*24A*	*9MV*1202422A**	0.97	1.01	EHD4X48A**	MV20L24**B*	0.96	0.96
EA*4X60*24A*	*9MA*1202422A**	0.97	1.01	ENH4X48*21**	*9MAC0602120A**	0.94	1.02
ED*4X48F**	*8MV*0901716**	0.96	1.04	EHD4X60A**	*9MX*1002116A**	0.98	1.04
ED*4X48F**	*9MV*0801716A**	0.95	1.04	ED*4X48J**	*8MPV125	0.96	1.00
ED*4X48J**	*8MX*0902116**	0.96	1.00	ED*4X60J**	*9MVX080	0.98	1.02
ED*4X48J**	*8MX*1102120**	0.95	0.99	ED*4X48L**	*9MVX100	0.96	1.04
ED*4X48J**	*8MV*1102120**	0.95	1.03	EA*4X48*21A*	*9MV*1002116A**	0.95	1.04
ED*4X48J**	*9MX*1202422A**	0.95	1.00	EN(A,D)4X61*24**	OLV154F20A	1.01	1.05
ED*4X48J**	*9MV*1202422A**	0.95	1.00	EHD4X48A**	*9MAC0602120A**	0.95	1.01
ED*4X48J**	*9MA*1202422A**	0.95	1.00	ENH4X60*24**	-	0.98	1.06
ED*4X48L**	*8MX*1352420**	0.96	1.00	EA*4X48*21A*	*9MX*1002116A**	0.95	1.04
ED*4X48L**	*8MV*1352422**	0.96	1.00	EN(A,D)4X48*24**	*9MV*1002116A**	0.96	1.05
ED*4X48L**	*9MX*1202422A**	0.96	1.01	EN(A,D,W)4X60*24**	OLV154F20A	0.99	1.03
ED*4X48L**	*9MV*1202422A**	0.96	1.01	EHD4X60A**	-	0.98	1.06
ED*4X48L**	*9MA*1202422A**	0.95	1.00	ENH4X60*24**	*9MPV100	0.98	1.02
ED*4X60J**	*8MX*0902116**	0.98	1.02	EHD4X48A**	*9MVX080	0.96	1.04
ED*4X60J**	*8MX*1102120**	0.98	0.98	ED*4X60L**	*9MVX100	0.98	1.02
ED*4X60J**	*8MV*1102120**	0.97	1.01	EA*4X48*24A*	*9MV*1002116A**	0.95	1.04
ED*4X60J**	*9MV*1202422A**	0.97	1.01	EHD4X60A**	*8MPV100	0.98	1.02
ED*4X60L**	*8MX*1352420**	0.98	1.02	ENH4X60*24**	*9MPV125	0.98	1.02
ED*4X60L**	*8MV*1352422**	0.97	1.01	EA*4X48*24A*	*9MX*1002116A**	0.95	1.04
ED*4X60L**	*9MX*1202422A**	0.98	1.02	EN(A,D)4X61*24**	*9MV*1002116A**	0.98	1.02
ED*4X60L**	*9MV*1202422A**	0.98	1.02	ENH4X48*21**	OLV154F20A	0.97	1.05
ED*4X60L**	*9MA*1202422A**	0.97	1.02	ENH4X60*24**	OLV154F20A	0.99	1.03
ED*4X60L**	*9MX*1202422A**	0.97	1.01	EHD4X60A**	*8MPV125	0.98	0.98
ED*4X60L**	*9MV*1202422A**	0.97	1.01	ENH4X61*24**	-	0.99	1.08
EHD4X48A**	*9MA*1202422A**	0.97	1.01	ENH4X61*24**	*9MPV100	0.98	1.02
EHD4X48A**	*8MX*0902116**	0.97	1.01	ENH4X60A**	*9MVX080	0.98	1.02
EHD4X48A**	*8MX*1102120**	0.97	1.01	EHD4X48A**	*9MVX100	0.96	1.04
EHD4X48A**	*8MX*1352420**	0.96	1.00	EA*4X60*21A*	*9MX*1002116A**	0.97	1.03
EHD4X48A**	*8MV*0901716**	0.96	1.00	EN(A,D)4X48*24**	*9MX*1002116A**	0.95	1.03
EHD4X48A**	*8MV*1102120**	0.96	1.00	EA*4X60*21A*	*9MV*1002116A**	0.97	1.05

COOLING Multiplying Factors for other Indoor Combinations

Indoor Model	Furnace Model	CAPACITY (MBh)	Power (AMPS)	Indoor Model	Furnace Model	CAPACITY (MBh)	Power (AMPS)
EHD4X48A**	*8MV*1352422**	0.97	1.01	EN(A,D,W)4X48*21**	*9MV*1002116A**	0.96	1.05
EHD4X48A**	*9MX*0801716A**	0.96	1.05	ED*4X48L**	*9MA*1002120A**	0.95	1.03
EHD4X48A**	*9MX*0802120A**	0.97	1.03	EN(A,D,W)4X48*21**	*9MA*1002120A**	0.95	1.03
EHD4X48A**	*9MX*1002120A**	0.96	1.02	EN(A,D)4X61*24**	OLV112A16A	0.98	1.06
EHD4X48A**	*9MX*1202422A**	0.97	1.03	ENH4X61*24**	OLV154F20A	1.00	1.04
EHD4X48A**	*9MV*0801716A**	0.96	1.05	ED*4X48J**	*9MPV100	0.96	1.04
EHD4X48A**	*9MV*0802120A**	0.96	1.02	ED*4X60J**	*9MPV100	0.98	1.02
EHD4X48A**	*9MV*1002120A**	0.96	1.00	EHD4X48A**	*8MPV100	0.96	1.04
EHD4X48A**	*9MV*1202422A**	0.96	1.01	EHD4X60A**	*9MPV100	0.98	1.02
EHD4X48A**	*9MA*0802120A**	0.96	1.02	EN(A,D)4X61*24**	*9MPV100	0.99	1.03
EHD4X48A**	*9MA*1002122A**	0.96	1.00	EN(A,D,W)4X60*24**	*9MPV100	0.98	1.02
EHD4X60A**	*8MX*0902116**	0.98	1.02	EN(A,D)4X48*24**	*9MVX080	0.96	1.04
EHD4X60A**	*8MX*1102120**	0.98	0.98	EHD4X60A**	*9MVX100	0.98	1.02
EHD4X60A**	*8MX*1352420**	0.98	1.02	EA*4X60*24A*	*9MX*1002116A**	0.97	1.03
EHD4X60A**	*8MV*0901716**	0.98	1.02	EN(A,D)4X61*24**	*9MX*1002116A**	0.98	1.02
EHD4X60A**	*8MV*1102120**	0.98	1.02	EA*4X60*24A*	*9MV*1002116A**	0.97	1.05
EHD4X60A**	*8MV*1352422**	0.98	0.98	EN(A,D,W)4X60*24**	*9MV*1002116A**	0.97	1.03
EHD4X60A**	*9MX*0801716A**	0.97	1.05	ED*4X60J**	*9MA*1002120A**	0.96	1.01
EHD4X60A**	*9MX*0802120A**	0.98	1.02	EN(A,D,W)4X60*24**	*9MA*1002120A**	0.96	1.01
EHD4X60A**	*9MX*1002120A**	0.98	1.00	ED*4X48L**	OLV154F20A	0.97	1.05
EHD4X60A**	*9MX*1202422A**	0.98	1.02	EA*4X48*17A*	-	0.96	1.06
EHD4X60A**	*9MV*0801716A**	0.97	1.05	ED*4X48J**	MV16J22**B*	0.96	0.96
EHD4X60A**	*9MV*0802120A**	0.98	1.00	ED*4X60J**	MV16J22**B*	0.98	0.98
EHD4X60A**	*9MV*1002120A**	0.98	1.00	EHD4X48A**	*8MPV125	0.96	1.00
EHD4X60A**	*9MV*1202422A**	0.98	1.02	EHD4X60A**	*9MPV125	0.98	1.02
EHD4X60A**	*9MA*0802120A**	0.97	0.99	EN(A,D)4X61*24**	*9MPV125	0.99	1.03
EHD4X60A**	*9MA*1002122A**	0.98	1.00	EN(A,D,W)4X60*24**	*9MPV125	0.98	1.02
EN(A,D)4X48*24**	*8MX*1352420**	0.96	1.00	ED*4X48J**	*9MX*1002116A**	0.95	1.04
EN(A,D)4X48*24**	*8MV*1352422**	0.96	1.00	ENH4X48*21**	*9MV*1002116A**	0.96	1.05
EN(A,D)4X48*24**	*9MX*1202422A**	0.96	1.01	EA*4X48*21A*	*9MAC0602120A**	0.94	1.02
EN(A,D)4X48*24**	*9MV*1202422A**	0.96	1.01	EHD4X60A**	MV16J22**B*	0.98	0.98
EN(A,D)4X61*24**	*8MX*1352420**	0.99	0.99	ED*4X48J**	*9MX*1002116A**	0.95	1.04
EN(A,D)4X61*24**	*8MV*1102120**	0.98	1.00	ED*4X48F**	*9MV*1002116A**	0.96	1.05
EN(A,D)4X61*24**	*8MV*1352422**	0.99	0.99	ENH4X60*24**	*9MV*1002116A**	0.97	1.03
EN(A,D)4X61*24**	*9MX*1202422A**	0.99	1.03	EA*4X48*21A*	-	0.96	1.06

COOLING Multiplying Factors for other Indoor Combinations

Indoor Model	Furnace Model	CAPACITY (MBh)	Power (AMPS)	Indoor Model	Furnace Model	CAPACITY (MBh)	Power (AMPS)
EN(A,D)4X61*24**	*9MV*1202422A**	0.98	0.98	EHD4X60A**	MV20L24**B*	0.98	0.98
EN(A,D,W)4X48*21**	*8MX*0902116**	0.96	1.00	EN(A,D)4X61*24**	*9MVX080	0.99	1.03
EN(A,D,W)4X48*21**	*8MX*1102120**	0.96	1.00	EN(A,D)4X48*24**	*9MVX100	0.96	1.00
EN(A,D,W)4X48*21**	*8MV*1102120**	0.96	1.00	ED*4X48J**	*9MV*1002116A**	0.95	1.04
EN(A,D,W)4X48*21**	*9MX*0801716A**	0.95	1.04	ED*4X60L**	*9MA*1002120A**	0.96	1.01
EN(A,D,W)4X48*21**	*9MX*0802120A**	0.96	1.02	ENH4X48*21**	*9MA*1002120A**	0.95	1.03
EN(A,D,W)4X48*21**	*9MX*1002120A**	0.96	1.02	ED*4X60L**	OLV154F20A	0.99	1.03
EN(A,D,W)4X48*21**	*9MV*0801716A**	0.95	1.04	ED*4X48L**	-	0.96	1.04
EN(A,D,W)4X48*21**	*9MV*0802120A**	0.96	1.02	ED*4X60L**	-	0.98	1.06
EN(A,D,W)4X48*21**	*9MV*1002120A**	0.96	1.02	EHD4X48A**	*9MPV100	0.96	1.04
EN(A,D,W)4X48*21**	*9MA*0802120A**	0.95	1.01	EN(A,D,W)4X48*21**	-	0.96	1.04
EN(A,D,W)4X48*21**	*9MA*1002122A**	0.96	1.00	ENH4X48*21**	-	0.96	1.04
EN(A,D,W)4X60*24**	*8MX*1352420**	0.98	1.02	ED*4X48L**	*9MX*1002116A**	0.95	1.04
EN(A,D,W)4X60*24**	*8MV*1352422**	0.97	0.97	ENH4X61*24**	*9MV*1002116A**	0.97	1.03
EN(A,D,W)4X60*24**	*9MX*1202422A**	0.98	1.02	EA*4X48*24A*	-	0.96	1.06
EN(A,D,W)4X60*24**	*9MV*1202422A**	0.97	1.01	EHD4X60A**	*9MAC0602120A**	0.96	1.02
ENH4X48*21**	*8MX*0902116**	0.96	1.00	EN(A,D,W)4X48*21**	*9MVX080	0.96	1.04
ENH4X48*21**	*8MX*1102120**	0.96	1.00	EN(A,D)4X61*24**	*9MVX100	0.99	1.03
ENH4X48*21**	*8MX*1352420**	0.96	1.00	ED*4X60J**	*9MX*1002116A**	0.97	1.03
ENH4X48*21**	*8MV*0901716**	0.95	0.99	EN(A,D,W)4X48*21**	*9MX*1002116A**	0.95	1.03
ENH4X48*21**	*8MV*1102120**	0.96	1.00	ED*4X48L**	*9MV*1002116A**	0.95	1.04
ENH4X48*21**	*8MV*1352422**	0.96	1.00	EA*4X48*21A*	*9MA*1002120A**	0.94	1.02
ENH4X48*21**	*9MX*0801716A**	0.95	1.04	ED*4X60L**	*9MA*1002120A**	0.96	1.01
ENH4X48*21**	*9MX*0802120A**	0.96	1.02	ENH4X60*24**	*9MA*1002120A**	0.96	1.01
ENH4X48*21**	*9MX*1002120A**	0.96	1.02	EHD4X48A**	OLV154F20A	0.98	1.06
ENH4X48*21**	*9MV*1202422A**	0.96	1.01	EA*4X60*21A*	*9MAC0602120A**	0.96	1.02
ENH4X48*21**	*9MV*0801716A**	0.95	1.04	ED*4X48L**	*9MPV125	0.96	1.04
ENH4X48*21**	*9MV*0802120A**	0.96	1.02	ED*4X60L**	*9MPV125	0.98	1.02
ENH4X48*21**	*9MV*1002120A**	0.96	1.02	EHD4X48A**	*9MPV125	0.96	1.04
ENH4X48*21**	*9MV*1202422A**	0.96	1.01	EMA4X48D**	-	0.94	1.02
ENH4X48*21**	*9MA*0802120A**	0.95	1.01	EN(A,D,W)4X48*21**	*9MPV100	0.96	1.04
ENH4X48*21**	*9MA*1002122A**	0.96	1.00	ENH4X48*21**	*9MPV100	0.96	1.04
ENH4X60*24**	*8MX*0902116**	0.98	1.02	EN(A,D,W)4X60*24**	*9MVX080	0.98	1.02
ENH4X60*24**	*8MX*1102120**	0.98	0.98	EN(A,D,W)4X60*24**	*9MVX100	0.98	1.02
ENH4X60*24**	*8MX*1352420**	0.98	1.02	ED*4X60L**	*9MX*1002116A**	0.97	1.03

COOLING Multiplying Factors for other Indoor Combinations

Indoor Model	Furnace Model	CAPACITY (MBh)	Power (AMPS)	Indoor Model	Furnace Model	CAPACITY (MBh)	Power (AMPS)
ENH4X60*24**	*8MV*0901716**	0.97	1.01	EN(A,D,W)4X60*24**	*9MX*1002116A**	0.97	1.03
ENH4X60*24**	*8MV*1102120**	0.97	1.01	ED*4X60J**	*9MV*1002116A**	0.97	1.05
ENH4X60*24**	*8MV*1352422**	0.97	0.97	EA*4X48*24A*	*9MA*1002120A**	0.95	1.03
ENH4X60*24**	*9MX*0801716A**	0.97	1.05	EHD4X48A**	*9MA*1002120A**	0.96	1.04
ENH4X60*24**	*9MX*1202422A**	0.98	1.02	EA*4X60*21A*	-	0.98	1.06
ENH4X60*24**	*9MV*0801716A**	0.97	1.05	ED*4X48L**	MV20L24**B*	0.96	0.96
ENH4X60*24**	*9MV*1202422A**	0.97	1.01	EN(A,D)4X48*24**	-	0.96	1.04
ENH4X61*24**	*8MX*0902116**	0.98	1.02	ENH4X48*21**	*9MVX080	0.96	1.04
ENH4X61*24**	*8MX*1102120**	0.98	0.98	ENH4X48*21**	*9MVX100	0.96	1.00
ENH4X61*24**	*8MX*1352420**	0.98	1.02	ED*4X60L**	*9MX*1002116A**	0.97	1.03
ENH4X61*24**	*8MV*0901716**	0.97	1.01	ENH4X48*21**	*9MX*1002116A**	0.95	1.03
ENH4X61*24**	*8MV*1102120**	0.98	1.02	ED*4X60L**	*9MV*1002116A**	0.97	1.05
ENH4X61*24**	*8MV*1352422**	0.98	0.98	EA*4X60*21A*	*9MA*1002120A**	0.96	1.01
ENH4X61*24**	*9MX*0801716A**	0.97	1.05	EHD4X60A**	*9MA*1002120A**	0.97	1.01
ENH4X61*24**	*9MX*1202422A**	0.98	1.02	EA*4X60*24A*	-	0.98	1.06
ENH4X61*24**	*9MV*0801716A**	0.96	1.01	ED*4X60J**	-	0.98	1.06
ENH4X61*24**	*9MV*1202422A**	0.97	1.01	EN(A,D)4X48*24**	*9MPV100	0.96	1.04
FEM4P48**A*	-	0.97	1.05	EHD4X60A**	*9MA*1202422A**	0.97	1.01
FEM4P48**A*	-	0.97	1.05	EN(A,D)4X48*24**	*9MA*1202422A**	0.95	1.00
FEM4P60**A*	-	0.99	1.03	EN(A,D)4X61*24**	*9MA*1202422A**	0.98	0.98
FEM4P60**A*	-	0.99	1.08	EN(A,D,W)4X60*24**	*9MA*1202422A**	0.97	1.01
FEM4X48****	-	0.99	1.03	ENH4X48*21**	*9MA*1202422A**	0.95	1.00
FEM4X60****	-	1.00	1.00	ENH4X60*24**	*9MA*1202422A**	0.97	1.01
FS(M,U)4P48**A*	-	0.98	1.02	ENH4X61*24**	*9MA*1202422A**	0.97	1.01
FS(M,U)4P48**A*	-	0.99	1.08	ED*4X48J**	NOMV156E19*	0.95	1.03
FS(M,U)4X48****	-	0.97	1.08	ED*4X60J**	NOMV156E19*	0.97	1.01
FS(M,U)4X60****	-	0.99	1.08	EHD4X48A**	NOMV156E19*	0.96	1.00
FS(M,U)4X60**A*	-	0.99	1.08	EHD4X60A**	NOMV156E19*	0.98	1.02
FVM4X48****	-	0.98	0.98	EN(A,D,W)4X48*21**	NOMV156E19*	0.95	0.99
FVM4X60****	-	0.99	0.97	ENH4X48*21**	NOMV156E19*	0.95	0.99
FXM4X60**A*	-	1.01	1.01	ENH4X60*24**	NOMV156E19*	0.97	1.01
-	-	-	-	ENH4X61*24**	*9MPV125	0.98	1.02

NXH560



COOLING Multiplying Factors for other Indoor Combinations

Indoor Model	Furnace Model	CAPACITY (MBh)	Power (AMPS)	Indoor Model	Furnace Model	CAPACITY (MBh)	Power (AMPS)
*FXM4X60**A*	-	1.00	1.00	EA*4X60*24A*	*9MX*1202422A**	0.97	1.03
EA*4X60*21A*	*8MX*1102120**	0.97	1.04	ENH4X61*24**	*9MX*1202422A**	0.97	1.03
EA*4X60*21A*	*8MV*1102120**	0.97	1.06	EA*4X60*24A*	*9MA*1002120A**	0.96	1.06
EA*4X60*21A*	*9MX*0802120A**	0.96	1.05	ENH4X60*24**	-	0.97	1.06
EA*4X60*24A*	*8MX*1352420**	0.97	1.04	ENH4X61*24**	*9MV*1202422A**	0.97	1.04
EA*4X60*24A*	*8MV*1352422**	0.97	1.04	ED*4X60J**	-	0.96	1.05
ED*4X60J**	*8MX*1102120**	0.97	1.01	EHD4X60A**	*9MV*1002120A**	0.98	1.05
ED*4X60J**	*8MX*1102120**	0.97	1.01	EA*4X60*24A*	*9MV*1202422A**	0.97	1.06
ED*4X60J**	*8MV*1102120**	0.97	1.06	ED*4X60L**	*9MA*1002120A**	0.96	1.06
ED*4X60J**	*8MV*1102120**	0.97	1.06	EHD4X60A**	*9MA*1002120A**	0.97	1.07
ED*4X60L**	*8MX*1352420**	0.97	1.01	EHD4X60A**	*9MA*0802120A**	0.97	1.04
ED*4X60L**	*8MX*1352420**	0.97	1.01	EA*4X60*21A*	*9MA*1002122A**	0.97	1.04
ED*4X60L**	*8MV*1352422**	0.97	1.01	ED*4X60J**	*8MPV125	0.98	1.07
ED*4X60L**	*8MV*1352422**	0.97	1.01	ED*4X60J**	MV16J22**B*	0.98	1.02
EHD4X60A**	*8MX*1102120**	0.98	1.02	ED*4X60J**	*9MV*1202422A**	0.97	1.07
EHD4X60A**	*8MX*1102120**	0.98	1.02	ED*4X60L**	*9MV*1202422A**	0.97	1.06
EHD4X60A**	*8MX*1352420**	0.98	1.02	EHD4X60A**	*9MA*1002122A**	0.98	1.05
EHD4X60A**	*8MX*1352420**	0.98	1.02	EA*4X60*24A*	*9MA*1202422A**	0.97	1.03
EHD4X60A**	*8MV*1102120**	0.98	1.07	EN(A,D)4X61*24**	*9MA*1002120A**	0.97	1.06
EHD4X60A**	*8MV*1102120**	0.98	1.07	EN(A,D,W)4X60*24**	*9MA*1002120A**	0.96	1.06
EHD4X60A**	*8MV*1352422**	0.98	1.02	ED*4X60L**	-	0.97	1.06
EHD4X60A**	*8MV*1352422**	0.98	1.02	ED*4X60L**	MV20L24**B*	0.98	1.02
EHD4X60A**	*9MX*0802120A**	0.97	1.04	ENH4X60*24**	-	0.97	1.06
EHD4X60A**	*9MX*1002120A**	0.98	1.07	ENH4X61*24**	-	0.98	1.07
EN(A,D)4X61*24**	*8MX*1352420**	0.99	1.03	ED*4X60L**	*9MA*1202422A**	0.97	1.04
EN(A,D)4X61*24**	*8MX*1352420**	0.99	1.03	ED*4X60L**	*9MA*1202422A**	0.97	1.03
EN(A,D)4X61*24**	*8MV*1352420**	0.99	1.03	EHD4X60A**	-	0.97	1.06
EN(A,D)4X61*24**	*8MV*1352422**	0.99	1.03	EHD4X60A**	*8MPV125	0.98	1.07
EN(A,D)4X60*24**	*8MV*1352422**	0.99	1.03	EHD4X60A**	*9MA*1202422A**	0.97	1.03
EN(A,D,W)4X60*24**	*8MX*1352420**	0.97	1.01	EN(A,D)4X61*24**	*9MA*1202422A**	0.98	1.04
EN(A,D,W)4X60*24**	*8MV*1352422**	0.97	1.01	EHD4X60A**	MV16J22**B*	0.98	1.02
EN(A,D,W)4X60*24**	*8MV*1352422**	0.97	1.01	EHD4X60A**	MV20L24**B*	0.98	0.98
ENH4X60*24**	*8MX*1102120**	0.97	1.01	EHD4X60A**	*9MV*1202422A**	0.98	1.07
ENH4X60*24**	*8MX*1102120**	0.97	1.01	EN(A,D)4X61*24**	*9MV*1202422A**	0.98	1.05
ENH4X60*24**	*8MX*1352420**	0.97	1.01	EN(A,D,W)4X60*24**	*9MA*1202422A**	0.97	1.03

COOLING Multiplying Factors for other Indoor Combinations

Indoor Model	Furnace Model	CAPACITY (MBh)	Power (AMPS)	Indoor Model	Furnace Model	CAPACITY (MBh)	Power (AMPS)
ENH4X60*24**	*8MX*1352420**	0.97	1.01	ENH4X60*24**	*9MA*1202422A**	0.97	1.03
ENH4X60*24**	*8MV*1102120**	0.97	1.06	ENH4X60*24**	*9MA*1002120A**	0.96	1.06
ENH4X60*24**	*8MV*1102120**	0.97	1.06	ENH4X61*24**	*9MA*1002120A**	0.96	1.06
ENH4X60*24**	*8MV*1352422**	0.97	1.01	EN(A,D)4X61*24**	-	0.99	1.08
ENH4X60*24**	*8MV*1352422**	0.97	1.01	EN(A,D)4X61*24**	-	0.99	1.08
ENH4X61*24**	*8MX*1102120**	0.98	1.02	EN(A,D,W)4X60*24**	*9MV*1202422A**	0.97	1.06
ENH4X61*24**	*8MX*1102120**	0.98	1.02	ENH4X60*24**	*9MV*1202422A**	0.97	1.06
ENH4X61*24**	*8MX*1352420**	0.97	1.01	ENH4X61*24**	*9MA*1202422A**	0.97	1.03
ENH4X61*24**	*8MX*1352420**	0.97	1.01	EA*4X60*21A*	*9MA*1002120A**	0.96	1.06
ENH4X61*24**	*8MV*1102120**	0.98	1.07	EA*4X60*21A*	-	0.97	1.06
ENH4X61*24**	*8MV*1102120**	0.98	1.07	EA*4X60*24A*	-	0.97	1.06
ENH4X61*24**	*8MV*1352422**	0.98	1.02	EN(A,D,W)4X60*24**	-	0.97	1.06
ENH4X61*24**	*8MV*1352422**	0.98	1.02	EN(A,D,W)4X60*24**	-	0.97	1.06
ENH4X61*24**	*8MV*1352422**	0.97	1.06	ED*4X60L**	*9MX*1202422A**	0.97	1.04
FEM4P60**A*	-	0.98	1.07	ED*4X60L**	*9MX*1202422A**	0.97	1.03
FEM4P60***	-	0.99	1.03	EHD4X60A**	*9MX*1202422A**	0.97	1.03
FS(M,U)4X60***	-	0.98	1.07	EN(A,D)4X61*24**	*9MX*1202422A**	0.98	1.04
FS(M,U)4X60***A*	-	0.98	1.07	EN(A,D,W)4X60*24**	*9MX*1202422A**	0.97	1.03
FVM4X60***	-	0.99	1.03	ENH4X60*24**	*9MX*1202422A**	0.97	1.03
-	-	-	-	ENH4X61*24**	-	0.98	1.07

HEATING Multiplying Factors for other Indoor Combinations

Indoor Model	Furnace Model	CAPACITY (MBh)	Power (AMPS)	Indoor Model	Furnace Model	CAPACITY (MBh)	Power (AMPS)
<b>NXH518</b>							
*FXM4X18**A*	-	1.00	1.00	EN(A,D)4X19*17**	*9MV*0601714A**	1.01	1.00
EA*4X18*14A*	*8MX*0451408**	1.00	1.07	ED*4X24F**	*9MA*0801714A**	0.99	1.05
EA*4X18*14A*	*8MV*0701412**	0.98	1.08	EN(A,D)4X24*17**	NOMV106D12*	1.00	1.03
EA*4X18*14A*	*9MX*0401410A**	0.99	1.10	EN(A,D)4X24*17**	OMV098J12A	1.01	1.01
EA*4X18*14A*	*9MV*0401410A**	1.00	1.10	EHD4X24A**	-	1.01	1.08
EA*4X24*14A*	*8MX*0451408**	1.01	1.03	EHD4X24A**	*9MA*0801714A**	0.99	1.05
EA*4X24*14A*	*8MV*0701412**	0.99	1.05	ENH4X24*17**	NOMV106D12*	1.00	1.03
EA*4X24*14A*	*9MX*0401410A**	1.00	1.07	ENH4X24*17**	OMV098J12A	1.01	1.01
EA*4X24*14A*	*9MV*0401410A**	1.01	1.07	EHD4X24A**	*8MPV050	1.01	1.01
EA*4X24*17A*	*8MV*0901716**	0.99	1.04	EN(A,D)4X19*17**	OLV098A12A	1.01	1.01
EA*4X24*17A*	*9MX*0401410A**	1.00	1.07	EA*4X24*14A*	-	1.01	1.10

HEATING Multiplying Factors for other Indoor Combinations

Indoor Model	Furnace Model	CAPACITY (MBh)	Power (AMPS)	Indoor Model	Furnace Model	CAPACITY (MBh)	Power (AMPS)
EA*4X24*17A*	*9MV*0401410A**	1.01	1.06	EHD4X24A**	*9MPV050	1.01	1.01
EA*4X24*17A*	*9MV*0601714A**	1.01	1.03	EN(A,D)4X24*17**	*9MPV050	1.01	1.00
ED*4X18B**	*8MX*0451408**	1.00	1.07	EN(A,D)4X19*17**	*9MA*0801714A**	0.99	1.03
ED*4X18B**	*8MV*0701412**	0.98	1.08	EHD4X24A**	*9MVX040	1.01	1.01
ED*4X18B**	*9MX*0401410A**	0.99	1.10	EA*4X24*17A*	-	1.01	1.10
ED*4X18B**	*9MV*0401410A**	1.00	1.10	EHD4X24A**	*9MPV075	1.01	1.01
ED*4X24B**	*8MX*0451408**	1.01	1.03	EN(A,D)4X24*17**	*9MA*0801714A**	0.99	1.05
ED*4X24B**	*8MV*0701412**	0.99	1.05	EN(A,D)4X24*17**	*9MVX040	1.01	1.00
ED*4X24B**	*9MX*0401410A**	1.00	1.07	ED*4X18B**	-	1.01	1.13
ED*4X24B**	*9MV*0401410A**	1.01	1.07	EHD4X24A**	MV08B15**B*	0.99	1.02
ED*4X24F**	*8MV*0901716**	0.99	1.04	EN(A,D)4X24*17**	OLV098A12A	1.01	1.02
ED*4X24F**	*9MV*0601714A**	1.01	1.03	ENH4X24*17**	-	1.01	1.08
EHD4X24A**	*9MX*0401410A**	1.00	1.08	ED*4X18B**	*8MPV050	1.01	1.05
EHD4X24A**	*9MV*0401410A**	1.01	1.07	EHD4X24A**	*9MAC0602120A**	1.01	1.04
EHD4X24A**	*9MV*0601714A**	1.00	1.05	ENH4X24*17**	*9MPV050	1.01	1.00
EHD4X24A**	*8MX*0451408**	1.01	1.04	ENH4X24*17**	*9MA*0801714A**	0.99	1.05
EHD4X24A**	*8MV*0701412**	0.99	1.05	ENH4X24*17**	*9MVX040	1.01	1.00
EHD4X24A**	*8MV*0901716**	0.99	1.04	ENH4X24*17**	OLV098A12A	1.01	1.02
EN(A,D)4X18*14**	*8MX*0451408**	1.00	1.05	ED*4X24F**	NOMV106D12*	1.00	1.04
EN(A,D)4X18*14**	*8MV*0701412**	0.98	1.05	EHD4X24A**	*9MVX060	1.01	1.01
EN(A,D)4X18*14**	*9MX*0401410A**	0.99	1.09	ED*4X18B**	MV08B15**B*	0.99	1.05
EN(A,D)4X18*14**	*9MV*0401410A**	1.01	1.09	EMA4X24D**	-	1.01	1.08
EN(A,D)4X19*17**	*8MV*0901716**	1.00	1.03	ED*4X24F**	OMV098J12A	1.01	1.02
EN(A,D)4X19*17**	*9MX*0401410A**	1.01	1.05	ED*4X24B**	-	1.01	1.10
EN(A,D)4X19*17**	*9MV*0401410A**	1.01	1.04	EN(A,D)4X18*14**	-	1.01	1.10
EN(A,D)4X24*14**	*8MX*0451408**	1.01	1.03	EHD4X24A**	NOMV106D12*	1.01	1.04
EN(A,D)4X24*14**	*8MV*0701412**	0.99	1.04	ED*4X24F**	OLV098A12A	1.01	1.03
EN(A,D)4X24*14**	*9MX*0401410A**	1.00	1.07	ED*4X24B**	*8MPV050	1.01	1.01
EN(A,D)4X24*14**	*9MV*0401410A**	1.01	1.06	EN(A,D)4X19*17**	-	1.01	1.07
EN(A,D)4X24*17**	*8MV*0901716**	0.99	1.04	EHD4X24A**	OMV098J12A	1.01	1.01
EN(A,D)4X24*17**	*9MX*0401410A**	1.00	1.07	ED*4X24B**	MV08B15**B*	0.99	1.02
EN(A,D)4X24*17**	*9MV*0401410A**	1.01	1.06	EN(A,D)4X24*14**	-	1.01	1.08
ENH4X24*17**	*8MX*0451408**	1.01	1.03	EN(A,D)4X19*17**	NOMV106D12*	1.01	1.02
ENH4X24*17**	*8MV*0701412**	0.99	1.04	EHD4X24A**	OLV098A12A	1.01	1.03
ENH4X24*17**	*8MV*0901716**	0.99	1.04	EN(A,D)4X19*17**	OMV098J12A	1.01	0.99

HEATING Multiplying Factors for other Indoor Combinations

Indoor Model	Furnace Model	CAPACITY (MBh)	Power (AMPS)	Indoor Model	Furnace Model	CAPACITY (MBh)	Power (AMPS)
ENH4X24*17**	*9MX*0401410A**	1.00	1.07	ED*4X24F**	-	1.01	1.10
ENH4X24*17**	*9MV*0401410A**	1.01	1.06	EN(A,D)4X24*17**	-	1.01	1.08
FEA4X18**A*	-	1.01	1.05	EN(A,D)4X24*17**	*9MV*0601714A**	1.01	1.03
FEA4X24**A*	-	1.01	1.02	ENH4X24*17**	*9MV*0601714A**	1.01	1.03
FEM4P18**A*	-	1.01	1.05	EA*4X24*17A*	*9MV*0801716A**	1.01	1.01
FEM4P18**A*	-	1.01	1.05	ED*4X24F**	*9MV*0801716A**	1.01	1.01
FEM4P24**A*	-	1.01	1.05	EHD4X24A**	*9MV*0801716A**	1.01	1.04
FEM4P24**A*	-	1.01	1.05	EN(A,D)4X19*17**	*9MV*0801716A**	1.01	0.99
FEM4X18****	-	1.01	1.05	EN(A,D)4X24*17**	*9MV*0801716A**	1.01	1.02
FEM4X24****	-	1.01	1.04	ENH4X24*17**	*9MV*0801716A**	1.01	1.02
FS(M,U)4P18**A*	-	1.01	1.09	EHD4X24A**	*9MV*0802120A**	1.01	1.02
FS(M,U)4P18**A*	-	1.01	1.08	EHD4X24A**	*9MV*1002120A**	1.01	1.01
FS(M,U)4P24**A*	-	1.01	1.08	EA*4X24*17A*	*9MA*0601714A**	0.99	1.05
FS(M,U)4P24**A*	-	1.01	1.08	ED*4X24F**	*9MA*0601714A**	0.99	1.05
FS(M,U)4X18****	-	1.01	1.12	EHD4X24A**	*9MA*0601714A**	1.00	1.05
FSA4X18**A*	-	1.01	1.12	EN(A,D)4X19*17**	*9MA*0601714A**	1.00	1.03
FSA4X24**A*	-	1.01	1.11	EN(A,D)4X24*17**	*9MA*0601714A**	1.00	1.05
FVM4X24****	-	1.00	1.02	ENH4X24*17**	*9MA*0601714A**	1.00	1.05
FXM4X24**A*	-	1.01	1.02	EA*4X24*17A*	*9MA*0801714A**	0.99	1.05

HEATING Multiplying Factors for other Indoor Combinations

Indoor Model	Furnace Model	CAPACITY (MBh)	Power (AMPS)	Indoor Model	Furnace Model	CAPACITY (MBh)	Power (AMPS)
NXH524							
*FXM4X24**A*	-	1.00	1.00	EHD4X30A**	*9MA*0601714A**	1.00	1.03
EA*4X24*14A*	*8MX*0451408**	1.00	1.03	EHD4X30A**	*9MA*0802120A**	1.00	0.99
EA*4X24*14A*	*8MV*0701412**	1.00	1.05	EHD4X24A**	NOMV106D12*	1.00	1.04
EA*4X24*14A*	*9MX*0401410A**	1.00	1.06	ENH4X24*17**	*9MV*1002116A**	1.00	1.05
EA*4X24*14A*	*9MV*0401410A**	1.00	1.08	EA*4X30*14A*	-	1.00	1.06
EA*4X24*17A*	*8MV*0901716**	1.00	1.04	EHD4X24A**	*9MVX040	1.00	1.03
EA*4X24*17A*	*9MX*0401410A**	1.00	1.05	ENH4X30*17**	*9MV*1002116A**	1.00	1.03
EA*4X24*17A*	*9MX*0601714A**	1.00	1.04	ENH4X24*17**	OLV098A12A	1.00	1.01
EA*4X24*17A*	*9MV*0401410A**	1.00	1.07	EA*4X30*17A*	-	1.00	1.06
EA*4X24*17A*	*9MV*0601714A**	1.00	1.05	ED*4X30F**	*9MPV075	1.00	1.01
EA*4X24*17A*	*9MV*0801716A**	1.00	1.04	EHD4X24A**	MV12F19**B*	1.00	1.00
EA*4X24*17A*	*9MA*0601714A**	1.00	1.05	EN(A,D)4X30*17**	*9MPV075	1.00	1.01

HEATING Multiplying Factors for other Indoor Combinations

Indoor Model	Furnace Model	CAPACITY (MBh)	Power (AMPS)	Indoor Model	Furnace Model	CAPACITY (MBh)	Power (AMPS)
EA*4X30*14A*	*8MX*0451408**	1.00	1.02	EHD4X24A**	*9MA*1002122A**	1.00	1.00
EA*4X30*14A*	*8MV*0701412**	1.00	1.04	EHD4X30A**	NOMV106D12*	1.00	1.04
EA*4X30*14A*	*9MX*0401410A**	1.00	1.05	ENH4X31*17**	*9MV*1002116A**	1.00	0.98
EA*4X30*14A*	*9MV*0401410A**	1.00	1.06	ED*4X24B**	-	1.00	1.06
EA*4X30*17A*	*8MV*0901716**	1.00	1.03	EHD4X30A**	*9MVX040	1.00	1.02
EA*4X30*17A*	*9MX*0401410A**	1.00	1.04	ED*4X24F**	*9MA*1002120A**	1.00	1.03
EA*4X30*17A*	*9MV*0601714A**	1.00	1.03	ENH4X30*17**	OLV098A12A	1.00	1.02
EA*4X30*17A*	*9MV*0401410A**	1.00	1.06	ED*4X24B**	*8MPV050	1.00	1.03
EA*4X30*17A*	*9MV*0601714A**	1.00	1.03	ED*4X30F**	MV12F19**B*	1.00	1.01
EA*4X30*17A*	*9MV*0801716A**	1.00	1.02	EHD4X24A**	*9MAC0602120A**	1.00	1.03
EA*4X30*17A*	*9MA*0601714A**	1.00	1.04	EN(A,D)4X31*17**	-	1.00	1.01
ED*4X24B**	*8MX*0451408**	1.00	1.03	EHD4X30A**	*9MA*1002122A**	1.00	0.99
ED*4X24B**	*8MV*0701412**	1.00	1.05	EN(A,D)4X24*17**	NOMV106D12*	1.00	1.03
ED*4X24B**	*9MX*0401410A**	1.00	1.06	ED*4X30F**	*9MA*1002120A**	1.00	1.02
ED*4X24B**	*9MV*0401410A**	1.00	1.08	ED*4X24B**	MV08B15**B*	1.00	1.02
ED*4X24F**	*8MV*0901716**	1.00	1.04	EN(A,D)4X24*17**	*9MVX040	1.00	1.03
ED*4X24F**	*9MX*0601714A**	1.00	1.04	ED*4X24F**	OMV098J12A	1.00	1.03
ED*4X24F**	*9MV*0601714A**	1.00	1.05	EHD4X24A**	-	1.00	1.04
ED*4X24F**	*9MV*0801716A**	1.00	1.04	EHD4X30A**	-	1.00	1.05
ED*4X24F**	*9MA*0601714A**	1.00	1.05	ENH4X24*17**	-	1.00	1.04
ED*4X30B**	*8MX*0451408**	1.00	1.02	EHD4X24A**	*9MA*1202422A**	1.00	1.02
ED*4X30B**	*8MV*0701412**	1.00	1.04	EN(A,D)4X30*17**	NOMV106D12*	1.00	1.04
ED*4X30B**	*9MX*0401410A**	1.00	1.05	EHD4X24A**	*9MA*1002120A**	1.00	1.01
ED*4X30B**	*9MV*0401410A**	1.00	1.06	ED*4X24F**	-	1.00	1.06
ED*4X30F**	*8MV*0901716**	1.00	1.03	EN(A,D)4X30*17**	*9MVX040	1.00	1.02
ED*4X30F**	*9MX*0601714A**	1.00	1.03	ED*4X30F**	OMV098J12A	1.00	1.02
ED*4X30F**	*9MV*0601714A**	1.00	1.03	EHD4X24A**	*8MPV050	1.00	1.02
ED*4X30F**	*9MV*0801716A**	1.00	1.02	EHD4X30A**	*8MPV050	1.00	1.01
ED*4X30F**	*9MA*0601714A**	1.00	1.04	ENH4X24*17**	*9MPV050	1.00	1.03
EHD4X24A**	*9MX*0401410A**	1.00	1.04	EHD4X30A**	*9MA*1002120A**	1.00	1.00
EHD4X24A**	*9MV*0601714A**	1.00	1.05	EHD4X24A**	OMV098J12A	1.00	1.02
EHD4X24A**	*9MV*0401410A**	1.00	1.07	ED*4X24F**	*8MPV075	1.00	1.00
EHD4X24A**	*9MV*0601714A**	1.00	1.05	EHD4X24A**	*8MPV075	1.00	1.01
EHD4X24A**	*9MV*0801716A**	1.00	1.04	EHD4X30A**	*8MPV075	1.00	0.99
EHD4X24A**	*9MA*0802120A**	1.00	1.06	EHD4X30A**	MV12F19**B*	1.00	1.01

HEATING Multiplying Factors for other Indoor Combinations

Indoor Model	Furnace Model	CAPACITY (MBh)	Power (AMPS)	Indoor Model	Furnace Model	CAPACITY (MBh)	Power (AMPS)
EHD4X24A**	*9MV*1002120A**	1.00	1.05	EMA4X24D**	-	1.00	1.04
EHD4X24A**	*9MV*1202422A**	1.00	1.05	EN(A,D)4X24*17**	-	1.00	1.04
EHD4X24A**	*9MA*0601714A**	1.00	1.04	ENH4X30*17**	-	1.00	1.06
EHD4X24A**	*8MX*0451408**	1.00	1.03	EHD4X30A**	*9MA*1202422A**	1.00	1.01
EHD4X24A**	*8MV*0701412**	1.00	1.03	EN(A,D)4X31*17**	NOMV106D12*	1.00	0.99
EHD4X24A**	*8MV*0901716**	1.00	1.02	ENH4X24*17**	*9MVX040	1.00	1.03
EHD4X24A**	*8MV*1102120**	1.00	1.03	EHD4X24A**	*9MVX080	1.00	0.99
EHD4X24A**	*8MV*1352422**	1.00	1.03	ED*4X24F**	*9MV*1002116A**	1.00	1.05
EHD4X30A**	*8MX*0451408**	1.00	1.02	ENH4X24*17**	*9MA*1202422A**	1.00	1.02
EHD4X30A**	*8MV*0701412**	1.00	1.04	ENH4X24*17**	NOMV106D12*	1.00	1.03
EHD4X30A**	*8MV*0901716**	1.00	1.03	ENH4X30*17**	*9MVX040	1.00	1.02
EHD4X30A**	*8MV*1102120**	1.00	1.03	EHD4X30A**	*9MVX080	1.00	0.98
EHD4X30A**	*8MV*1352422**	1.00	1.03	ED*4X30F**	*9MV*1002116A**	1.00	1.03
EHD4X30A**	*9MX*0401410A**	1.00	1.03	ENH4X24*17**	*9MA*1002120A**	1.00	1.01
EHD4X30A**	*9MX*0601714A**	1.00	1.02	EHD4X30A**	OMV098J12A	1.00	1.02
EHD4X30A**	*9MV*0401410A**	1.00	1.05	ED*4X24F**	*9MPV050	1.00	1.03
EHD4X30A**	*9MV*0601714A**	1.00	1.03	EHD4X24A**	*8MPV100	1.00	0.98
EHD4X30A**	*9MV*0801716A**	1.00	1.02	EHD4X30A**	*8MPV100	1.00	0.97
EHD4X30A**	*9MV*0802120A**	1.00	1.01	EHD4X30A**	*9MAC0602120A**	1.00	1.02
EHD4X30A**	*9MV*1002120A**	1.00	0.99	EN(A,D)4X24*14**	-	1.00	1.04
EHD4X30A**	*9MV*1202422A**	1.00	1.01	EN(A,D)4X24*17**	*9MPV050	1.00	1.03
EN(A,D)4X24*14**	*8MX*0451408**	1.00	1.02	ENH4X30*17**	*9MA*1202422A**	1.00	1.02
EN(A,D)4X24*14**	*8MV*0701412**	1.00	1.03	ENH4X30*17**	NOMV106D12*	1.00	1.04
EN(A,D)4X24*14**	*9MX*0401410A**	1.00	1.04	ENH4X30*17**	*9MA*1002120A**	1.00	1.02
EN(A,D)4X24*14**	*9MV*0401410A**	1.00	1.06	ED*4X24F**	*9MPV075	1.00	1.03
EN(A,D)4X24*17**	*8MV*0901716**	1.00	1.02	ED*4X24F**	*9MVX060	1.00	1.01
EN(A,D)4X24*17**	*9MX*0401410A**	1.00	1.04	ENH4X31*17**	*9MA*1002120A**	1.00	0.97
EN(A,D)4X24*17**	*9MX*0601714A**	1.00	1.04	EN(A,D)4X24*17**	OMV098J12A	1.00	1.02
EN(A,D)4X24*17**	*9MV*0401410A**	1.00	1.06	ED*4X24F**	MV12F19**B*	1.00	1.02
EN(A,D)4X24*17**	*9MV*0601714A**	1.00	1.04	EHD4X24A**	*8MPV125	1.00	0.98
EN(A,D)4X24*17**	*9MV*0801716A**	1.00	1.03	EHD4X30A**	*8MPV125	1.00	0.97
EN(A,D)4X30*14**	*8MX*0451408**	1.00	1.03	ENH4X31*17**	*9MA*1202422A**	1.00	0.98
EN(A,D)4X30*14**	*8MV*0701412**	1.00	1.04	ENH4X31*17**	NOMV106D12*	1.00	0.99
EN(A,D)4X30*14**	*9MX*0401410A**	1.00	1.05	ED*4X24F**	OLV098A12A	1.00	1.03
EN(A,D)4X30*14**	*9MV*0401410A**	1.00	1.07	ED*4X30B**	-	1.00	1.06

HEATING Multiplying Factors for other Indoor Combinations

Indoor Model	Furnace Model	CAPACITY (MBh)	Power (AMPS)	Indoor Model	Furnace Model	CAPACITY (MBh)	Power (AMPS)
EN(A,D)4X30*17**	*8MV*0901716**	1.00	1.03	ED*4X30F**	*9MPVX060	1.00	1.00
EN(A,D)4X30*17**	*9MX*0401410A**	1.00	1.04	ED*4X30F**	OLV098A12A	1.00	1.02
EN(A,D)4X30*17**	*9MX*0601714A**	1.00	1.03	EN(A,D)4X30*17**	OMV098J12A	1.00	1.02
EN(A,D)4X30*17**	*9MV*0401410A**	1.00	1.06	ED*4X30B**	*8MPV050	1.00	1.02
EN(A,D)4X30*17**	*9MV*0601714A**	1.00	1.03	EHD4X24A**	*9MPV050	1.00	1.04
EN(A,D)4X30*17**	*9MV*0801716A**	1.00	1.02	EHD4X30A**	*9MPV050	1.00	1.03
EN(A,D)4X31*17**	*8MV*0901716**	1.00	0.99	EHD4X24A**	*9MPVX060	1.00	1.02
EN(A,D)4X31*17**	*9MX*0401410A**	1.00	0.99	EHD4X24A**	OLV098A12A	1.00	1.02
EN(A,D)4X31*17**	*9MX*0601714A**	1.00	0.98	ENH4X24*17**	OMV098J12A	1.00	1.02
EN(A,D)4X31*17**	*9MV*0401410A**	1.00	1.01	ED*4X30B**	MV08B15**B*	1.00	1.01
EN(A,D)4X31*17**	*9MV*0601714A**	1.00	0.99	EHD4X24A**	*9MPV075	1.00	1.04
EN(A,D)4X31*17**	*9MV*0801716A**	1.00	0.97	EHD4X30A**	*9MPV075	1.00	1.02
ENH4X24*17**	*8MX*0451408**	1.00	1.02	ED*4X24F**	NOMV106D12*	1.00	1.05
ENH4X24*17**	*8MV*0701412**	1.00	1.03	ED*4X24F**	*9MPVX040	1.00	1.03
ENH4X24*17**	*8MV*0901716**	1.00	1.02	EHD4X30A**	*9MPVX060	1.00	1.01
ENH4X24*17**	*8MV*1102120**	1.00	1.03	EHD4X24A**	*9MPVX100	1.00	0.99
ENH4X24*17**	*8MV*1352422**	1.00	1.02	EHD4X24A**	*9MV*1002116A**	1.00	1.07
ENH4X24*17**	*9MX*0401410A**	1.00	1.04	EHD4X30A**	OLV098A12A	1.00	1.02
ENH4X24*17**	*9MX*0601714A**	1.00	1.04	ENH4X30*17**	OMV098J12A	1.00	1.02
ENH4X24*17**	*9MV*0401410A**	1.00	1.06	ED*4X30F**	-	1.00	1.06
ENH4X24*17**	*9MV*0601714A**	1.00	1.04	EHD4X24A**	*9MPV100	1.00	1.01
ENH4X24*17**	*9MV*0801716A**	1.00	1.03	EHD4X30A**	*9MPV100	1.00	0.99
ENH4X30*17**	*9MV*1202422A**	1.00	1.03	EN(A,D)4X30*14**	-	1.00	1.06
ENH4X30*17**	*8MX*0451408**	1.00	1.02	ED*4X30F**	NOMV106D12*	1.00	1.04
ENH4X30*17**	*8MV*0701412**	1.00	1.04	ED*4X30F**	*9MPVX040	1.00	1.02
ENH4X30*17**	*8MV*0901716**	1.00	1.03	EN(A,D)4X30*17**	*9MPVX060	1.00	1.00
ENH4X30*17**	*8MV*1102120**	1.00	1.03	EHD4X30A**	*9MPVX100	1.00	0.98
ENH4X30*17**	*8MV*1352422**	1.00	1.03	EHD4X30A**	*9MV*1002116A**	1.00	1.03
ENH4X30*17**	*9MX*0401410A**	1.00	1.04	EN(A,D)4X24*17**	OLV098A12A	1.00	1.01
ENH4X30*17**	*9MX*0601714A**	1.00	1.03	EA*4X24*14A*	-	1.00	1.06
ENH4X30*17**	*9MV*0601714A**	1.00	1.06	ED*4X30F**	*8MPV075	1.00	0.99
ENH4X30*17**	*9MV*0401410A**	1.00	1.03	EHD4X24A**	*9MPV125	1.00	0.99
ENH4X30*17**	*9MV*0801716A**	1.00	1.02	EHD4X30A**	*9MPV125	1.00	0.98
ENH4X30*17**	*9MV*1202422A**	1.00	1.01	EN(A,D)4X30*17**	-	1.00	1.06
ENH4X31*17**	*9MX*0401410A**	1.00	0.99	EN(A,D)4X30*17**	OLV098A12A	1.00	1.02

HEATING Multiplying Factors for other Indoor Combinations						
Indoor Model	Furnace Model	CAPACITY (MBh)	Power (AMPS)	Indoor Model	Furnace Model	Power (AMPS)
ENH4X31*17**	*9MX*0601714A**	1.00	0.98	EA*4X24*17A*	-	1.06
ENH4X31*17**	*9MV*0401410A**	1.00	1.01	ED*4X30F**	*9MPV050	1.02
ENH4X31*17**	*9MV*0601714A**	1.00	0.99	EHD4X24A**	MV08B15**B*	1.00
ENH4X31*17**	*9MV*0801716A**	1.00	0.97	EHD4X30A**	MV08B15**B*	1.01
ENH4X31*17**	*9MV*1202422A**	1.00	0.95	EN(A,D)4X30*17**	*9MPV050	1.02
FEA4X24**A*	-	1.00	1.03	EN(A,D)4X24*17**	*9MA*0601714A**	1.03
FEA4X30**A*	-	1.00	1.03	EN(A,D)4X30*17**	*9MA*0601714A**	1.04
FEM4P24**A*	-	1.00	1.05	EN(A,D)4X31*17**	*9MA*0601714A**	0.99
FEM4P24**A*	-	1.00	1.05	ENH4X24*17**	*9MA*0601714A**	1.03
FEM4P30**A*	-	1.00	1.00	ENH4X30*17**	*9MA*0601714A**	1.04
FEM4P30**A*	-	1.00	1.01	ENH4X31*17**	*9MA*0601714A**	0.99
FEM4X24****	-	1.00	1.03	EA*4X24*17A*	*9MA*0801714A**	1.05
FEM4X30****	-	1.00	1.00	EA*4X30*17A*	*9MA*0801714A**	1.05
FS(M,U)4P24**A*	-	1.00	1.04	ED*4X24F**	*9MA*0801714A**	1.05
FS(M,U)4P24**A*	-	1.00	1.04	ED*4X30F**	*9MA*0801714A**	1.05
FS(M,U)4P30**A*	-	1.00	1.03	EHD4X24A**	*9MA*0801714A**	1.04
FS(M,U)4P30**A*	-	1.00	1.03	EHD4X30A**	*9MA*0801714A**	1.03
FS(M,U)4X24****	-	1.00	1.09	EN(A,D)4X24*17**	*9MA*0801714A**	1.04
FS(M,U)4X30****	-	1.00	1.06	EN(A,D)4X30*17**	*9MA*0801714A**	1.04
FSA4X24**A*	-	1.00	1.09	EN(A,D)4X31*17**	*9MA*0801714A**	1.00
FSA4X30**A*	-	1.00	1.08	ENH4X24*17**	*9MA*0801714A**	1.04
FVM4X24****	-	1.00	1.01	ENH4X30*17**	*9MA*0801714A**	1.04
FVM4X36****	-	1.03	1.03	ENH4X31*17**	*9MA*0801714A**	1.00
FXM4X30**A*	-	1.00	1.02	EHD4X24A**	*9MA*0802120A**	1.01
-	-	-	-	ENH4X30*17**	*9MPV050	1.02
HEATING Multiplying Factors for other Indoor Combinations						
Indoor Model	Furnace Model	CAPACITY (MBh)	Power (AMPS)	Indoor Model	Furnace Model	Power (AMPS)
NXH530						
*FXM4X30**A*	-	1.00	1.00	ENH4X36*17**	*9MA*0601714A**	1.05
EA*4X30*14A*	*8MV*0701412**	0.99	1.04	EN(A,D)4X31*17**	*9MVX040	1.02
EA*4X30*14A*	*9MV*0401410A**	1.01	1.12	ED*4X30F**	*8MPV075	1.03
EA*4X30*17A*	*8MX*0701716**	0.99	1.03	EHD4X30A**	*9MA*1002122A**	1.00
EA*4X30*17A*	*8MV*0901716**	0.98	1.02	ENH4X36*17**	*9MVX060	1.04
EA*4X30*17A*	*9MX*0601714A**	0.99	1.03	ED*4X30F**	OMV098J12A	1.04



HEATING Multiplying Factors for other Indoor Combinations

Indoor Model	Furnace Model	CAPACITY (MBh)	Power (AMPS)	Indoor Model	Furnace Model	CAPACITY (MBh)	Power (AMPS)
EA*4X30*17A*	*9MX*0801716A**	1.00	1.03	EN(A,D)4X31*17**	OMV112K14A	1.00	0.99
EA*4X30*17A*	*9MV*0401410A**	1.01	1.11	ED*4X30F**	*9MPV050	1.00	1.06
EA*4X30*17A*	*9MV*0601714A**	0.99	1.04	EHD4X30A**	-	1.02	1.08
EA*4X30*17A*	*9MV*0801716A**	0.99	1.03	EHD4X36A**	*8MPV100	1.00	0.98
EA*4X30*17A*	*9MA*0601714A**	0.99	1.04	EN(A,D,W)4X36*17**	-	1.02	1.09
EA*4X36*14A*	*8MV*0701412**	0.99	1.03	EN(A,D)4X36*21**	*9MVX040	1.00	1.05
EA*4X36*17A*	*9MV*0401410A**	1.01	1.11	ED*4X30F**	*9MPV075	1.00	1.05
EA*4X36*17A*	*8MX*0701716**	0.99	1.02	EHD4X36A**	*9MA*1002122A**	1.00	0.99
EA*4X36*17A*	*8MV*0901716**	0.98	1.01	ED*4X36J**	*9MVX080	1.00	1.00
EA*4X36*17A*	*9MX*0601714A**	0.99	1.02	ED*4X36F**	OMV098J12A	0.99	1.03
EA*4X36*17A*	*9MX*0801716A**	1.00	1.02	EN(A,D)4X36*21**	OMV112K14A	0.99	1.02
EA*4X36*17A*	*9MV*0401410A**	1.01	1.11	ED*4X30F**	MV12F19**B*	0.98	0.99
EA*4X36*17A*	*9MV*0601714A**	0.99	1.03	EHD4X30A**	*8MPV050	1.01	1.06
EA*4X36*17A*	*9MV*0801716A**	0.99	1.02	EHD4X36A**	*8MPV125	0.99	0.97
EA*4X36*17A*	*9MA*0601714A**	0.99	1.03	EN(A,D,W)4X36*17**	*9MPV050	1.00	1.06
EA*4X36*21A*	*8MX*0902116**	0.99	1.00	EN(A,D,W)4X36*17**	NOMV106D12*	0.98	1.04
EA*4X36*21A*	*8MV*1102120**	0.99	1.01	EHD4X36A**	*9MA*1002120A**	1.00	1.00
EA*4X36*21A*	*9MX*0601714A**	1.00	1.03	EHD4X30A**	OMV098J12A	1.00	1.05
EA*4X36*21A*	*9MX*0801716A**	1.00	1.01	EN(A,D,W)4X36*17**	OMV112K14A	0.99	1.02
EA*4X36*21A*	*9MV*0601714A**	0.99	1.03	EHD4X30A**	*8MPV075	1.00	1.03
EA*4X36*21A*	*9MV*0801716A**	0.99	1.02	EHD4X36A**	*9MPV050	1.00	1.02
EA*4X36*21A*	*9MV*0802120A**	0.99	1.00	EN(A,D)4X30*17**	*9MPV075	1.00	1.05
EA*4X36*21A*	*9MA*0601714A**	0.99	1.01	EN(A,D)4X31*17**	*9MPV075	1.01	1.02
EA*4X36*21A*	*8MV*0701412**	0.99	1.03	EN(A,D,W)4X36*17**	*9MPV075	1.00	1.05
ED*4X30B**	*8MV*0701412**	0.99	1.04	EN(A,D,W)4X36*17**	*9MVX040	1.00	1.06
ED*4X30B**	*9MV*0401410A**	1.01	1.12	ENH4X30*17**	*9MVX040	1.00	1.06
ED*4X30F**	*8MX*0701716**	0.99	1.03	ED*4X36B**	-	1.02	1.09
ED*4X30F**	*8MX*0701716**	0.99	1.03	EN(A,D)4X36*21**	*9MA*1002122A**	0.99	1.01
ED*4X30F**	*8MV*0901716**	0.98	1.02	EHD4X30A**	*9MA*1202422A**	0.99	1.01
ED*4X30F**	*8MV*0901716**	0.98	1.02	EHD4X30A**	*9MVX080	1.00	1.02
ED*4X30F**	*8MV*0901716**	0.98	1.02	EHD4X36A**	*9MVX080	1.00	0.98
ED*4X30F**	*9MX*0601714A**	0.99	1.03	EHD4X36A**	OMV098J12A	1.00	1.02
ED*4X30F**	*9MX*0801716A**	1.00	1.03	ENH4X30*17**	OMV112K14A	0.99	1.02
ED*4X30F**	*9MV*0601714A**	0.99	1.04	EHD4X30A**	*8MPV100	0.99	1.01
ED*4X30F**	*9MV*0801716A**	0.99	1.03	EHD4X36A**	*9MPV075	1.00	1.02

HEATING Multiplying Factors for other Indoor Combinations

Indoor Model	Furnace Model	CAPACITY (MBh)	Power (AMPS)	Indoor Model	Furnace Model	CAPACITY (MBh)	Power (AMPS)
ED*4X36F**	*9MA*0601714A**	0.99	1.04	ENH4X30*17**	-	1.02	1.09
ED*4X36B**	*8MV*0701412**	0.99	1.03	ENH4X31*17**	*9MVX040	1.01	1.02
ED*4X36B**	*8MV*0701412**	0.99	1.03	ENH4X36*17**	*9MVX040	1.00	1.06
ED*4X36B**	*9MV*0401410A**	1.01	1.11	ED*4X36B**	*8MPV050	1.01	1.07
ED*4X36F**	*8MX*0701716**	0.99	1.02	EHD4X36A**	*9MA*1202422A**	0.99	0.99
ED*4X36F**	*8MX*0701716**	0.99	1.02	ENH4X30*17**	*9MA*1202422A**	0.99	1.02
ED*4X36F**	*8MV*0901716**	0.98	1.01	EN(A,D)4X36*21**	*9MVX080	1.00	1.02
ED*4X36F**	*8MV*0901716**	0.98	1.01	ENH4X36*17**	*9MVX080	1.00	1.02
ED*4X36F**	*9MX*0601714A**	0.99	1.02	EN(A,D)4X30*17**	OMV098J12A	0.99	1.04
ED*4X36F**	*9MX*0601714A**	0.99	1.02	EN(A,D)4X31*17**	OMV098J12A	1.01	1.01
ED*4X36F**	*9MX*0801716A**	1.00	1.02	ENH4X31*17**	OMV112K14A	1.00	0.99
ED*4X36F**	*9MX*0801716A**	1.00	1.02	ENH4X36*17**	OMV112K14A	0.99	1.02
ED*4X36F**	*9MV*0601714A**	0.99	1.03	EHD4X30A**	*8MPV125	0.99	1.01
ED*4X36F**	*9MV*0801716A**	0.99	1.02	EHD4X36A**	*9MPV100	1.00	0.99
ED*4X36F**	*9MA*0601714A**	0.99	1.04	ENH4X30*17**	-	1.02	1.09
ED*4X36F**	*9MA*0601714A**	0.99	1.04	ENH4X30*17**	*9MPV050	1.00	1.06
ED*4X36J**	*8MX*0902116**	0.99	1.00	EN(A,D,W)4X36*17**	NOMV106D12*	0.98	1.04
ED*4X36J**	*8MX*0902116**	0.99	1.00	ENH4X30*17**	NOMV106D12*	0.98	1.04
ED*4X36J**	*8MV*1102120**	0.99	1.01	EN(A,D)4X36*21**	*9MA*1002120A**	0.99	1.02
ED*4X36J**	*8MV*1102120**	0.99	1.01	ENH4X30*17**	*9MA*1002120A**	0.99	1.02
ED*4X36J**	*9MV*1202422A**	0.99	1.00	EN(A,D)4X36*21**	*9MPV075	1.00	1.05
EHD4X30A**	*8MX*0701716**	0.99	1.03	ENH4X31*17**	*9MA*1202422A**	1.00	0.99
EHD4X30A**	*8MX*0701716**	0.99	1.03	ENH4X36*17**	*9MA*1202422A**	0.99	1.02
EHD4X30A**	*8MX*0902116**	0.99	1.03	ENH4X30*17**	NOMV106D12*	0.98	1.04
EHD4X30A**	*8MX*0902116**	0.99	1.03	ENH4X31*17**	NOMV106D12*	0.99	1.00
EHD4X30A**	*8MV*0701412**	0.99	1.03	ED*4X30F**	*9MVX060	1.00	1.04
EHD4X30A**	*8MV*0701412**	0.99	1.03	ED*4X36F**	*9MVX060	1.00	1.03
EHD4X30A**	*8MV*0901716**	0.99	1.02	EHD4X30A**	*9MVX100	0.99	1.02
EHD4X30A**	*8MV*0901716**	0.99	1.02	EHD4X36A**	*9MVX100	1.00	0.99
EHD4X30A**	*8MV*1102120**	0.99	1.02	ENH4X31*17**	*9MA*1002120A**	1.00	0.99
EHD4X30A**	*8MV*1102120**	0.99	1.02	ENH4X36*17**	*9MA*1002120A**	0.99	1.02
EHD4X30A**	*8MV*1352422**	0.99	1.02	ENH4X30*17**	OLV098A12A	0.99	1.04
EHD4X30A**	*8MV*1352422**	0.99	1.02	ENH4X31*17**	OLV098A12A	1.00	1.01
EHD4X30A**	*9MX*0601714A**	1.00	1.03	EN(A,D)4X36*21**	OMV098J12A	0.99	1.04
EHD4X30A**	*9MX*0801716A**	1.01	1.02	EA*4X30*14A*	-	1.02	1.09

HEATING Multiplying Factors for other Indoor Combinations

Indoor Model	Furnace Model	CAPACITY (MBh)	Power (AMPS)	Indoor Model	Furnace Model	CAPACITY (MBh)	Power (AMPS)
EHD4X30A**	*9MV*0401410A**	1.01	1.10	ED*4X36B**	MV08B15**B*	0.99	1.00
EHD4X30A**	*9MV*0601714A**	0.99	1.03	EHD4X30A**	*9MPV050	1.00	1.06
EHD4X30A**	*9MV*0801716A**	0.99	1.02	EHD4X36A**	*9MPV125	1.00	0.98
EHD4X30A**	*9MV*0802120A**	0.99	1.01	EN(A,D)4X31*17**	-	1.03	1.06
EHD4X30A**	*9MV*1002120A**	0.98	1.02	EN(A,D)4X36*21**	-	1.02	1.09
EHD4X30A**	*9MV*1202422A**	0.99	1.01	EN(A,D)4X36*21**	*9MPV100	0.99	1.02
EHD4X30A**	*9MA*0601714A**	1.00	1.04	ENH4X30*17**	*9MPV075	1.00	1.05
EHD4X36A**	*8MX*0701716**	1.00	1.01	ED*4X30F**	NOMV106D12*	0.98	1.04
EHD4X36A**	*8MX*0701716**	1.00	1.01	ED*4X30F**	NOMV106D12*	0.98	1.04
EHD4X36A**	*8MX*0902116**	1.00	0.99	ENH4X31*17**	NOMV106D12*	0.99	1.00
EHD4X36A**	*8MX*0902116**	1.00	0.99	ENH4X36*17**	NOMV106D12*	0.98	1.04
EHD4X36A**	*8MV*0701412**	0.99	1.01	EHD4X30A**	*9MVX060	1.00	1.05
EHD4X36A**	*8MV*0701412**	0.99	1.01	EHD4X36A**	*9MVX060	1.00	1.01
EHD4X36A**	*8MV*0901716**	0.99	0.99	EA*4X36*21A*	*9MV*1002116A**	0.99	1.01
EHD4X36A**	*8MV*0901716**	0.99	0.99	ED*4X30F**	*9MV*1002116A**	0.99	1.03
EHD4X36A**	*8MV*1102120**	0.99	0.99	ED*4X30F**	OLV098A12A	0.99	1.03
EHD4X36A**	*8MV*1102120**	0.99	0.99	ED*4X36F**	OLV098A12A	0.99	1.03
EHD4X36A**	*8MV*1352422**	0.99	0.99	ENH4X36*17**	OLV098A12A	0.99	1.04
EHD4X36A**	*8MV*1352422**	0.99	0.99	ED*4X30F**	OLV112A16A	0.99	1.02
EHD4X36A**	*9MX*0401410A**	1.03	1.11	EN(A,D)4X36*21**	OLV112A16A	0.99	1.02
EHD4X36A**	*9MX*0601714A**	1.01	1.01	EN(A,D,W)4X36*17**	OMV098J12A	0.99	1.04
EHD4X36A**	*9MX*0801716A**	1.01	1.00	EA*4X30*17A*	-	1.02	1.09
EHD4X36A**	*9MV*0401410A**	1.01	1.08	ED*4X36F**	-	1.02	1.09
EHD4X36A**	*9MV*0601714A**	1.00	1.02	EHD4X30A**	*9MPV075	1.00	1.06
EHD4X36A**	*9MV*0801716A**	1.00	1.01	EHD4X36A**	MV08B15**B*	0.99	0.98
EHD4X36A**	*9MV*0802120A**	0.99	0.99	EN(A,D)4X31*17**	-	1.03	1.06
EHD4X36A**	*9MV*1002120A**	0.99	1.00	EN(A,D)4X36*21**	-	1.02	1.09
EHD4X36A**	*9MV*1202422A**	0.99	0.99	EN(A,D)4X36*21**	*9MAC0602120A**	0.99	1.03
EHD4X36A**	*9MA*0601714A**	1.00	1.02	ENH4X31*17**	*9MPV050	1.01	1.02
EN(A,D)4X30*14**	*8MV*0701412**	0.99	1.04	EN(A,D)4X30*17**	*9MVX060	1.00	1.04
EN(A,D)4X30*14**	*8MV*0701412**	0.99	1.04	EN(A,D)4X31*17**	*9MVX060	1.01	1.00
EN(A,D)4X30*14**	*9MV*0401410A**	1.01	1.13	ED*4X36F**	*8MPV075	1.00	1.02
EN(A,D)4X30*17**	*8MX*0701716**	0.99	1.03	ED*4X36F**	NOMV106D12*	0.98	1.03
EN(A,D)4X30*17**	*8MX*0701716**	0.99	1.03	ED*4X36F**	NOMV106D12*	0.98	1.03
EN(A,D)4X30*17**	*8MV*0901716**	0.98	1.01	ED*4X36F**	*9MV*1002116A**	0.99	1.02

HEATING Multiplying Factors for other Indoor Combinations

Indoor Model	Furnace Model	CAPACITY (MBh)	Power (AMPS)	Indoor Model	Furnace Model	CAPACITY (MBh)	Power (AMPS)
EN(A,D)4X30*17**	*8MV*0901716**	0.98	1.01	ED*4X36J**	*9MV*1002116A**	0.99	1.01
EN(A,D)4X30*17**	*9MX*0601714A**	0.99	1.03	ENH4X30*17**	OMV098J12A	0.99	1.04
EN(A,D)4X30*17**	*9MX*0801716A**	1.00	1.03	EA*4X36*14A*	-	1.02	1.09
EN(A,D)4X30*17**	*9MV*0401410A**	1.01	1.11	ED*4X36F**	*9MPV050	1.00	1.05
EN(A,D)4X30*17**	*9MV*0601714A**	0.99	1.04	EHD4X30A**	*9MPV100	0.99	1.03
EN(A,D)4X30*17**	*9MV*0801716A**	0.99	1.03	EHD4X36A**	MV12F19**B*	0.98	0.96
EN(A,D)4X30*17**	*9MA*0601714A**	0.99	1.05	ENH4X31*17**	*9MPV075	1.01	1.02
EN(A,D)4X31*17**	*8MX*0701716**	1.01	1.00	EHD4X30A**	NOMV106D12*	0.98	1.04
EN(A,D)4X31*17**	*8MX*0701716**	1.01	1.00	EHD4X30A**	NOMV106D12*	0.98	1.04
EN(A,D)4X31*17**	*8MV*0901716**	0.99	0.99	EHD4X30A**	*9MV*1002116A**	0.99	1.02
EN(A,D)4X31*17**	*8MV*0901716**	0.99	0.99	EHD4X36A**	*9MV*1002116A**	0.99	1.00
EN(A,D)4X31*17**	*9MX*0401410A**	1.03	1.10	ENH4X30*17**	OLV112A16A	0.99	1.02
EN(A,D)4X31*17**	*9MX*0601714A**	1.01	1.00	ENH4X31*17**	OMV098J12A	1.01	1.01
EN(A,D)4X31*17**	*9MX*0801716A**	1.01	0.99	EA*4X36*17A*	-	1.02	1.09
EN(A,D)4X31*17**	*9MV*0401410A**	1.02	1.08	ED*4X36F**	*9MPV075	1.00	1.04
EN(A,D)4X31*17**	*9MV*0601714A**	1.00	1.01	EHD4X30A**	*9MPV125	0.99	1.02
EN(A,D)4X31*17**	*9MV*0801716A**	1.00	1.00	EHD4X36A**	*9MAC0602120A**	1.00	1.01
EN(A,D)4X31*17**	*9MA*0601714A**	1.00	1.01	ENH4X31*17**	-	1.03	1.07
EN(A,D)4X36*21**	*8MX*0902116**	0.99	1.02	ENH4X36*17**	NOMV106D12*	0.98	1.04
EN(A,D)4X36*21**	*8MX*0902116**	0.99	1.02	ED*4X30F**	*9MVX040	1.00	1.05
EN(A,D)4X36*21**	*8MV*1102120**	0.99	1.02	EHD4X30A**	OLV098A12A	0.99	1.04
EN(A,D)4X36*21**	*8MV*1102120**	0.99	1.02	EHD4X36A**	OLV098A12A	1.00	1.02
EN(A,D)4X36*21**	*9MX*0601714A**	0.99	1.03	ENH4X36*17**	OMV098J12A	0.99	1.04
EN(A,D)4X36*21**	*9MX*0801716A**	1.00	1.03	EA*4X36*21A*	*9MAC0602120A**	0.99	1.02
EN(A,D)4X36*21**	*9MV*0601714A**	0.99	1.04	EHD4X30A**	MV08B15**B*	0.99	1.00
EN(A,D)4X36*21**	*9MV*0801716A**	0.99	1.03	EMA4X36D**	-	1.02	1.09
EN(A,D)4X36*21**	*9MV*0802120A**	0.99	1.02	EN(A,D)4X31*17**	*9MPV050	1.01	1.02
EN(A,D)4X36*21**	*9MV*1002120A**	0.98	1.03	EN(A,D)4X36*21**	*9MPV050	1.00	1.06
EN(A,D)4X36*21**	*9MA*0601714A**	0.99	1.05	ENH4X36*17**	-	1.02	1.09
EN(A,D)4X37*17**	*8MX*0701716**	1.01	0.97	EHD4X36A**	NOMV106D12*	0.99	1.01
EN(A,D)4X37*17**	*8MX*0701716**	1.01	0.97	EHD4X36A**	NOMV106D12*	0.99	1.01
EN(A,D)4X37*17**	*8MV*0901716**	0.99	0.96	EN(A,D)4X36*21**	*9MV*1002116A**	0.99	1.03
EN(A,D)4X37*17**	*8MV*0901716**	0.99	0.96	ENH4X30*17**	*9MV*1002116A**	0.99	1.03
EN(A,D)4X37*17**	*9MX*0401410A**	1.03	1.07	ENH4X31*17**	OLV112A16A	1.01	0.99
EN(A,D)4X37*17**	*9MX*0601714A**	1.01	0.97	ED*4X30F**	OMV112K14A	0.99	1.02

HEATING Multiplying Factors for other Indoor Combinations

Indoor Model	Furnace Model	CAPACITY (MBh)	Power (AMPS)	Indoor Model	Furnace Model	CAPACITY (MBh)	Power (AMPS)
EN(A,D)4X37*17**	*9MX*0801716A**	1.01	0.96	EA*4X36*21A*	-	1.02	1.09
EN(A,D)4X37*17**	*9MV*0401410A**	1.02	1.05	ED*4X36F**	MV12F19**B*	0.98	0.98
EN(A,D)4X37*17**	*9MV*0601714A**	1.01	0.98	EHD4X30A**	MV12F19**B*	0.98	0.99
EN(A,D)4X37*17**	*9MV*0801716A**	1.01	0.97	EN(A,D)4X30*14**	-	1.02	1.09
EN(A,D)4X37*17**	*9MA*0601714A**	1.01	0.99	ENH4X36*17**	-	1.02	1.09
EN(A,D,W)4X36*17**	*8MX*0701716**	0.99	1.03	EN(A,D)4X30*17**	NOMV106D12*	0.98	1.04
EN(A,D,W)4X36*17**	*8MX*0701716**	0.99	1.03	EN(A,D)4X30*17**	NOMV106D12*	0.98	1.04
EN(A,D,W)4X36*17**	*8MV*0901716**	0.98	1.01	ENH4X31*17**	*9MV*1002116A**	1.00	1.00
EN(A,D,W)4X36*17**	*8MV*0901716**	0.98	1.01	ENH4X36*17**	*9MV*1002116A**	0.99	1.03
EN(A,D,W)4X36*17**	*9MX*0601714A**	0.99	1.03	ED*4X36F**	OMV112K14A	0.99	1.01
EN(A,D,W)4X36*17**	*9MX*0801716A**	1.00	1.03	ED*4X30B**	-	1.02	1.09
EN(A,D,W)4X36*17**	*9MV*0401410A**	1.01	1.11	ED*4X36J**	-	1.02	1.09
EN(A,D,W)4X36*17**	*9MV*0601714A**	0.99	1.04	EHD4X30A**	*9MAC0602120A**	1.00	1.03
EN(A,D,W)4X36*17**	*9MV*0801716A**	0.99	1.03	EN(A,D)4X30*14**	-	1.02	1.09
EN(A,D,W)4X36*17**	*9MA*0601714A**	0.99	1.05	ENH4X36*17**	*9MPV050	1.00	1.06
ENH4X30*17**	*8MX*0701716**	0.99	1.03	EN(A,D)4X31*17**	NOMV106D12*	0.99	1.00
ENH4X30*17**	*8MX*0701716**	0.99	1.03	EN(A,D)4X31*17**	NOMV106D12*	0.99	1.00
ENH4X30*17**	*8MX*0902116**	0.99	1.02	ED*4X36F**	*9MVX040	1.00	1.05
ENH4X30*17**	*8MX*0902116**	0.99	1.02	EHD4X30A**	*9MVX040	1.00	1.06
ENH4X30*17**	*8MV*0701412**	0.99	1.03	EN(A,D)4X36*21**	*9MVX060	1.00	1.04
ENH4X30*17**	*8MV*0701412**	0.99	1.03	EN(A,D,W)4X36*17**	*9MVX060	1.00	1.04
ENH4X30*17**	*8MV*0901716**	0.98	1.01	EA*4X36*21A*	*9MA*1002120A**	0.99	1.01
ENH4X30*17**	*8MV*0901716**	0.98	1.01	ED*4X36F**	*9MA*1002120A**	0.99	1.02
ENH4X30*17**	*8MV*1102120**	0.99	1.02	EN(A,D)4X30*17**	OLV098A12A	0.99	1.04
ENH4X30*17**	*8MV*1102120**	0.99	1.02	EN(A,D)4X31*17**	OLV098A12A	1.00	1.01
ENH4X30*17**	*8MV*1352422**	0.99	1.02	ED*4X36F**	OLV112A16A	0.99	1.02
ENH4X30*17**	*8MV*1352422**	0.99	1.02	ED*4X36J**	OLV112A16A	0.99	1.01
ENH4X30*17**	*9MX*0601714A**	0.99	1.03	EHD4X30A**	OMV112K14A	0.99	1.02
ENH4X30*17**	*9MX*0801716A**	1.00	1.03	ED*4X30B**	*8MPV050	1.01	1.07
ENH4X30*17**	*9MV*0401410A**	1.01	1.11	ED*4X36J**	*8MPV100	1.00	1.00
ENH4X30*17**	*9MV*0601714A**	0.99	1.04	EHD4X36A**	-	1.02	1.05
ENH4X30*17**	*9MV*0801716A**	0.99	1.03	EN(A,D)4X30*17**	-	1.02	1.09
ENH4X30*17**	*9MV*1202422A**	0.99	1.02	EN(A,D)4X37*17**	-	1.03	1.03
ENH4X30*17**	*9MA*0601714A**	0.99	1.05	ENH4X36*17**	*9MPV075	1.00	1.05
ENH4X31*17**	*9MX*0401410A**	1.03	1.10	ENH4X36*17**	OLV112A16A	0.99	1.02

HEATING Multiplying Factors for other Indoor Combinations

Indoor Model	Furnace Model	CAPACITY (MBh)	Power (AMPS)	Indoor Model	Furnace Model	CAPACITY (MBh)	Power (AMPS)
ENH4X31*17**	*9MX*0601714A**	1.01	1.00	EHD4X36A**	OMV112K14A	0.99	0.99
ENH4X31*17**	*9MX*0801716A**	1.01	0.99	ED*4X30B**	MV08B15**B*	0.99	1.01
ENH4X31*17**	*9MV*0401410A**	1.02	1.08	ED*4X36J**	*8MPV125	0.99	0.98
ENH4X31*17**	*9MV*0601714A**	1.00	1.01	EHD4X36A**	*8MPV050	1.02	1.04
ENH4X31*17**	*9MV*0801716A**	1.00	1.00	EN(A,D)4X30*17**	-	1.02	1.09
ENH4X31*17**	*9MV*1202422A**	1.00	0.98	EN(A,D)4X37*17**	-	1.03	1.03
ENH4X36*17**	*9MA*0601714A**	1.00	1.01	ENH4X36*17**	*9MPV100	0.99	1.02
ENH4X36*17**	*8MX*0701716**	0.99	1.03	EN(A,D)4X37*17**	NOMV106D12*	0.99	0.98
ENH4X36*17**	*8MX*0701716**	0.99	1.03	EN(A,D)4X37*17**	NOMV106D12*	0.99	0.98
ENH4X36*17**	*8MX*0902116**	0.99	1.02	EHD4X36A**	*9MVX040	1.00	1.02
ENH4X36*17**	*8MX*0902116**	0.99	1.02	EN(A,D)4X30*17**	*9MVX040	1.00	1.06
ENH4X36*17**	*8MV*0701412**	0.99	1.03	ENH4X30*17**	*9MVX060	1.00	1.04
ENH4X36*17**	*8MV*0701412**	0.99	1.03	ENH4X31*17**	*9MVX060	1.01	1.00
ENH4X36*17**	*8MV*0901716**	0.98	1.01	ED*4X36J**	*9MA*1002120A**	0.99	1.01
ENH4X36*17**	*8MV*0901716**	0.98	1.01	EHD4X30A**	*9MA*1002120A**	1.00	1.02
ENH4X36*17**	*8MV*1102120**	0.99	1.02	EN(A,D)4X36*21**	OLV098A12A	0.99	1.04
ENH4X36*17**	*8MV*1102120**	0.99	1.02	EN(A,D,W)4X36*17**	OLV098A12A	0.99	1.04
ENH4X36*17**	*8MV*1352422**	0.99	1.02	EHD4X30A**	OLV112A16A	1.00	1.03
ENH4X36*17**	*8MV*1352422**	0.99	1.02	EHD4X36A**	OLV112A16A	1.00	1.00
ENH4X36*17**	*9MX*0601714A**	0.99	1.03	EN(A,D)4X30*17**	OMV112K14A	0.99	1.02
ENH4X36*17**	*9MX*0801716A**	1.00	1.03	ED*4X30F**	-	1.02	1.09
ENH4X36*17**	*9MV*0401410A**	1.01	1.11	ED*4X36J**	*9MPV100	1.00	1.01
ENH4X36*17**	*9MV*0601714A**	0.99	1.04	EHD4X36A**	*8MPV075	1.00	0.99
ENH4X36*17**	*9MV*0801716A**	0.99	1.03	EN(A,D)4X30*17**	*9MPV050	1.00	1.06
ENH4X36*17**	*9MV*1202422A**	0.99	1.02	EN(A,D,W)4X36*17**	-	1.02	1.09
FEA4X30**A*	-	1.00	1.03	EA*4X30*17A*	*9MA*0801714A**	0.99	1.03
FEA4X36**A*	-	1.01	1.04	EA*4X36*17A*	*9MA*0801714A**	0.99	1.03
FEM4P30**A*	-	1.00	1.03	EA*4X36*21A*	*9MA*0801714A**	0.99	1.02
FEM4P30**A*	-	1.00	1.03	ED*4X30F**	*9MA*0801714A**	0.99	1.03
FEM4P36**A*	-	1.00	1.03	ED*4X36F**	*9MA*0801714A**	0.99	1.03
FEM4P36**A*	-	1.00	1.03	ED*4X36F**	*9MA*0801714A**	0.99	1.03
FEM4X30****	-	1.00	1.02	EHD4X30A**	*9MA*0801714A**	1.00	1.03
FEM4X36****	-	1.01	1.01	EHD4X36A**	*9MA*0801714A**	1.00	1.01
FS(M,U)4P30**A*	-	1.01	1.04	EN(A,D)4X30*17**	*9MA*0801714A**	0.99	1.03
FS(M,U)4P30**A*	-	1.01	1.04	EN(A,D)4X31*17**	*9MA*0801714A**	1.00	1.00

HEATING Multiplying Factors for other Indoor Combinations						
Indoor Model	Furnace Model	CAPACITY (MBh)	Power (AMPS)	Indoor Model	Furnace Model	Power (AMPS)
FS(M,U)4P36**A*	-	1.01	1.06	EN(A,D)4X36*21**	*9MA*0801714A**	1.03
FS(M,U)4P36**A*	-	1.01	1.06	EN(A,D)4X37*17**	*9MA*0801714A**	0.97
FS(M,U)4X30****	-	1.01	1.08	EN(A,D,W)4X36*17**	*9MA*0801714A**	1.03
FSA4X30**A*	-	1.01	1.10	ENH4X30*17**	*9MA*0801714A**	1.03
FSA4X36**A*	-	1.02	1.09	ENH4X31*17**	*9MA*0801714A**	1.00
FSM4X36****	-	1.03	1.07	ENH4X36*17**	*9MA*0801714A**	1.03
FSU4X36****	-	1.02	1.10	EA*4X36*21A*	*9MA*0802120A**	1.01
FVM4X24****	-	0.99	1.01	EHD4X30A**	*9MA*0802120A**	1.01
FVM4X36****	-	0.98	0.99	EHD4X36A**	*9MA*0802120A**	0.99
FVM4X48****	-	0.98	0.94	EN(A,D)4X36*21**	*9MA*0802120A**	1.02
FXM4X36**A*	-	0.99	0.98	EA*4X36*21A*	*9MA*1002122A**	1.00
HEATING Multiplying Factors for other Indoor Combinations						
Indoor Model	Furnace Model	CAPACITY (MBh)	Power (AMPS)	Indoor Model	Furnace Model	Power (AMPS)
<b>NXH536</b>						
EHD4X36A**	*9MX*0801716A**	0.98	1.03	EN(A,D)4X43*24**	OLV154F20A	0.97
EN(A,D)4X37*17**	*9MX*0801716A**	0.99	1.01	ENH4X43*21**	OLV154F20A	0.97
EHD4X36A**	*9MA*0801714A**	0.98	1.04	EHD4X42A**	MV16J22**B*	0.97
EHD4X42A**	*9MA*0801714A**	0.98	1.03	EHD4X42A**	MV20L24**B*	0.97
EN(A,D)4X36*21**	*9MA*0802120A**	0.97	1.05	EN(A,D)4X43*24**	*9MPV125	0.97
ED*4X42J**	*8MX*1102120**	0.98	1.01	EN(A,D)4X43*24**	*9MPV100	0.98
EN(A,D)4X36*21**	*9MA*0601714A**	0.97	1.08	EHD4X36A**	MV12F19**B*	0.98
EN(A,D)4X37*17**	*9MA*0601714A**	0.99	1.03	EHD4X36A**	MV16J22**B*	0.98
ENH4X42*21**	*9MA*0601714A**	0.98	1.06	EHD4X42A**	*8MPV100	0.98
ENH4X43*21**	*9MA*0601714A**	0.99	1.03	EHD4X42A**	*8MPV125	0.98
ED*4X42F**	*9MA*0801714A**	0.97	1.05	EHD4X42A**	MV12F19**B*	0.98
-	-	-	-	ENH4X43*21**	*9MPV125	0.98
EN(A,D)4X36*21**	*8MX*0902116**	0.98	1.04	EN(A,D)4X43*24**	*9MPV080	0.99
ENH4X42*21**	*8MX*0902116**	0.98	1.02	ENH4X43*21**	*9MPV080	0.99
ED*4X36J**	*8MX*1102120**	0.98	1.02	EHD4X42A**	*9MPV100	0.99
EHD4X36A**	*8MX*1102120**	0.99	1.00	ENH4X43*21**	*9MPV100	0.99
ENH4X42*21**	*9MX*0601714A**	0.99	1.05	EN(A,D)4X43*24**	OLV112A16A	0.99
ED*4X42F**	*9MX*0801716A**	0.98	1.05	EHD4X42A**	OLV154F20A	0.99
EA*4X42*21A*	*9MA*0601714A**	0.98	1.06	EHD4X36A**	*8MPV125	0.99
EN(A,D)4X37*17**	*9MA*0601714A**	0.99	1.03	EHD4X36A**	MV20L24**B*	0.99

HEATING Multiplying Factors for other Indoor Combinations

Indoor Model	Furnace Model	CAPACITY (MBh)	Power (AMPS)	Indoor Model	Furnace Model	CAPACITY (MBh)	Power (AMPS)
ED*4X36F**	*9MA*0801714A**	0.97	1.06	EHD4X42A**	*9MPV125	0.99	0.99
EHD4X42A**	*9MA*0802120A**	0.98	1.01	EN(A,D)4X43*24**	*9MPV100	1.01	0.99
EHD4X42A**	NOMV106D12*	0.98	1.02	ENH4X43*21**	*9MPV100	1.01	0.99
FSM4X36***	-	1.02	1.08	ENH4X43*21**	NOMV156E19*	0.99	1.00
EHD4X36A**	*8MX*0902116**	0.99	1.01	EHD4X42A**	*9MVX080	1.00	1.00
EA*4X36*17A*	*8MV*0901716**	0.97	1.04	EN(A,D)4X43*24**	*9MV*1002116A**	0.99	1.00
EN(A,D)4X36*17**	*8MV*0901716**	0.99	0.99	ENH4X43*21**	*9MV*1002116A**	0.98	1.00
EN(A,D)4X36*21**	*8MV*1102120**	0.97	1.05	EN(A,D)4X43*24**	*9MA*1002120A**	0.99	1.00
EA*4X42*24A*	*8MV*1352422**	0.97	1.02	ENH4X43*21**	*9MA*1002120A**	0.99	1.00
EA*4X42*21A*	*9MX*0801716A**	0.98	1.04	ENH4X43*21**	OLV112A16A	1.00	1.00
ED*4X36F**	*9MX*0801716A**	0.98	1.06	EHD4X36A**	OLV154F20A	1.01	1.00
ENH4X36*17**	*9MV*0601714A**	0.98	1.08	EN(A,D)4X37*17**	OMV112K14A	0.99	1.00
ED*4X36F**	*9MV*0801716A**	0.98	1.06	ENH4X43*21**	OMV112K14A	0.99	1.00
EHD4X36A**	*9MV*1202422A**	0.98	1.02	ED*4X42J**	MV16J22**B*	0.97	1.00
ENH4X36*17**	*9MV*1202422A**	0.97	1.05	ED*4X42L**	MV20L24**B*	0.97	1.00
EA*4X36*21A*	*9MA*0601714A**	0.97	1.07	EHD4X36A**	*8MPV100	0.99	1.00
EHD4X36A**	*9MA*0601714A**	0.98	1.05	EHD4X36A**	*9MPV125	0.99	1.00
EHD4X42A**	*9MA*0601714A**	0.98	1.04	EHD4X36A**	MV08B15**B*	0.98	1.00
EA*4X42*21A*	*9MA*0801714A**	0.97	1.05	EHD4X42A**	*9MPV100	0.99	1.00
ED*4X36F**	*9MA*0801714A**	0.97	1.06	EHD4X42A**	MV08B15**B*	0.99	1.00
*FXM4X36**A*	-	1.00	1.00	EN(A,D)4X37*17**	NOMV106D12*	0.99	1.01
FEM4P42**A*	-	1.00	1.01	ENH4X43*21**	NOMV106D12*	0.99	1.01
FS(M,U)4P36**A*	-	1.00	1.07	EHD4X42A**	NOMV156E19*	0.98	1.01
ED*4X42J**	*8MX*0902116**	0.98	1.01	EHD4X36A**	*9MVX080	0.99	1.01
EA*4X42*21A*	*8MX*1102120**	0.98	1.01	EHD4X36A**	*9MVX100	0.99	1.01
ED*4X36F**	*9MX*0801716A**	0.98	1.06	ED*4X42L**	OLV154F20A	1.00	1.01
EN(A,D)4X36*21**	*9MX*0801716A**	0.97	1.06	ENH4X42*21**	OLV154F20A	1.00	1.01
EHD4X42A**	*9MV*0802120A**	0.98	1.01	ED*4X36F**	MV12F19**B*	0.97	1.01
ENH4X42*21**	*9MV*0802120A**	0.98	1.04	ED*4X36J**	*8MPV125	0.99	1.01
EA*4X42*21A*	*9MV*1002120A**	0.98	1.02	ED*4X36J**	MV16J22**B*	0.97	1.01
ENH4X42*21**	*9MV*1002120A**	0.98	1.04	ED*4X42F**	MV12F19**B*	0.98	1.01
ED*4X42J**	*9MV*1202422A**	0.98	1.02	ED*4X42J**	*8MPV125	0.99	1.01
ENH4X36*17**	*9MA*0601714A**	0.97	1.08	EHD4X42A**	*8MPV075	0.99	1.01
FS(M,U)4P36**A*	-	1.00	1.07	EHD4X36A**	NOMV156E19*	0.98	1.02
EA*4X36*21A*	*8MX*1102120**	0.98	1.02	ED*4X42L**	*9MVX100	0.99	1.02



HEATING Multiplying Factors for other Indoor Combinations

Indoor Model	Furnace Model	CAPACITY (MBh)	Power (AMPS)	Indoor Model	Furnace Model	CAPACITY (MBh)	Power (AMPS)
ENH4X36*17**	*8MV*0701412**	0.98	1.06	EHD4X42A**	*9MV*1002116A**	0.99	1.02
EHD4X36A**	*8MV*1102120**	0.98	1.01	EHD4X42A**	*9MA*1002120A**	0.98	1.02
EHD4X36A**	*9MV*0601714A**	0.99	1.05	ENH4X43*21**	OMV098J12A	1.00	1.02
EN(A,D,W)4X42*21**	*9MV*0601714A**	0.99	1.06	EHD4X42A**	OMV112K14A	0.99	1.02
ED*4X36J**	*9MV*1202422A**	0.98	1.04	ED*4X42J**	*8MPV100	0.99	1.02
EN(A,D)4X43*24**	*9MV*1202422A**	0.98	0.98	ED*4X42L**	*9MPV125	0.99	1.02
EA*4X36*17A*	*9MA*0601714A**	0.97	1.08	EHD4X36A**	*8MPV075	0.99	1.02
ED*4X42F**	*9MA*0601714A**	0.98	1.07	EHD4X36A**	*9MPV100	0.99	1.02
EHD4X36A**	*8MX*0701716**	0.99	1.04	EHD4X42A**	*9MVX060	0.99	1.03
EN(A,D)4X37*17**	*8MX*0701716**	1.00	1.02	EN(A,D)4X37*17**	*9MVX060	1.01	1.03
EA*4X42*21A*	*8MX*0902116**	0.98	1.01	ED*4X36J**	*9MVX080	0.99	1.03
ED*4X36J**	*8MX*0902116**	0.98	1.02	ED*4X42J**	*9MVX080	1.00	1.03
EN(A,D,W)4X42*21**	*8MX*0902116**	0.98	1.02	EN(A,D,W)4X42*21**	*9MVX080	1.00	1.03
ENH4X36*17**	*8MX*0902116**	0.98	1.04	ENH4X42*21**	*9MVX080	1.00	1.03
EHD4X42A**	*8MV*0701412**	0.99	1.03	EHD4X36A**	*9MV*1002116A**	0.99	1.03
ED*4X42J**	*8MV*1102120**	0.98	1.03	EHD4X36A**	*9MA*1002120A**	0.98	1.03
ENH4X42*21**	*8MV*1352422**	0.97	1.02	EN(A,D)4X37*17**	OLV098A12A	1.00	1.03
ED*4X42F**	*9MX*0601714A**	0.99	1.06	ENH4X43*21**	OLV098A12A	1.00	1.03
EN(A,D,W)4X42*21**	*9MX*0601714A**	0.99	1.05	EHD4X36A**	OLV112A16A	0.99	1.03
END4X42*17**	*9MX*0601714A**	0.99	1.05	EHD4X42A**	OLV112A16A	1.00	1.03
ENH4X43*21**	*9MX*0801716A**	0.99	1.00	EN(A,D)4X37*17**	OMV098J12A	1.00	1.03
EN(A,D,W)4X36*17**	*9MV*0601714A**	0.98	1.08	EHD4X36A**	OMV112K14A	0.99	1.03
EN(A,D,W)4X42*21**	*9MV*0802120A**	0.98	1.04	ED*4X36J**	*8MPV100	0.99	1.03
ED*4X42L**	*9MV*1202422A**	0.98	1.02	ED*4X42J**	*9MPV100	0.99	1.03
EN(A,D)4X36*21**	*9MA*0801714A**	0.97	1.07	EHD4X42A**	*9MAC0602120A**	0.98	1.03
EA*4X42*21A*	*9MA*0802120A**	0.97	1.03	EN(A,D)4X37*17**	*9MPV075	1.01	1.03
FEM4P36**A*	-	0.99	1.06	END4X42*17**	NOMV106D12*	0.98	1.04
FEM4X36***	-	1.00	1.02	ED*4X36J**	NOMV156E19*	0.97	1.04
FEM4X42****	-	1.01	1.03	ED*4X42J**	NOMV156E19*	0.98	1.04
FS(M,U)4P42**A*	-	1.01	1.04	EN(A,D,W)4X42*21**	NOMV156E19*	0.98	1.04
FSA4X36**A*	-	1.01	1.11	ENH4X42*21**	NOMV156E19*	0.98	1.04
ED*4X36F**	*8MX*0701716**	0.98	1.06	EHD4X36A**	*9MVX060	0.99	1.04
EN(A,D)4X36*21**	*8MX*1102120**	0.98	1.04	EA*4X42*21A*	*9MV*1002116A**	0.99	1.04
EN(A,D,W)4X42*21**	*8MX*1102120**	0.98	1.01	EA*4X42*24A*	*9MV*1002116A**	0.99	1.04
EA*4X36*14A*	*8MV*0701412**	0.98	1.06	ED*4X42F**	*9MV*1002116A**	0.98	1.04

HEATING Multiplying Factors for other Indoor Combinations

Indoor Model	Furnace Model	CAPACITY (MBh)	Power (AMPS)	Indoor Model	Furnace Model	CAPACITY (MBh)	Power (AMPS)
ED*4X36B**	*8MV*0701412**	0.98	1.06	ED*4X42J**	*9MV*1002116A**	0.99	1.04
EHD4X36A**	*8MV*0701412**	0.98	1.03	ED*4X42L**	*9MV*1002116A**	0.99	1.04
ED*4X36F**	*8MV*0901716**	0.97	1.04	EN(A,D,W)4X42*21**	*9MV*1002116A**	0.98	1.04
EHD4X42A**	*8MV*0901716**	0.98	1.01	ENH4X42*21**	*9MV*1002116A**	0.98	1.04
END4X42*17**	*8MV*0901716**	0.98	1.02	EA*4X42*21A*	*9MA*1002120A**	0.98	1.04
ENH4X36*17**	*8MV*0901716**	0.97	1.05	EA*4X42*24A*	*9MA*1002120A**	0.98	1.04
EA*4X42*21A*	*8MV*1102120**	0.98	1.03	ED*4X42J**	*9MA*1002120A**	0.98	1.04
ED*4X36J**	*8MV*1102120**	0.97	1.04	ED*4X42L**	*9MA*1002120A**	0.98	1.04
EN(A,D)4X43*24**	*8MV*1352422**	0.98	0.97	EHD4X42A**	OLV098A12A	0.99	1.04
EN(A,D)4X37*17**	*9MX*0601714A**	1.00	1.02	ED*4X42J**	OLV112A16A	0.99	1.04
EN(A,D,W)4X36*17**	*9MX*0601714A**	0.98	1.08	ED*4X42L**	OLV112A16A	0.99	1.04
ENH4X43*21**	*9MX*0601714A**	1.00	1.01	EN(A,D,W)4X42*21**	OLV112A16A	0.99	1.04
EA*4X36*21A*	*9MX*0801716A**	0.98	1.05	ENH4X42*21**	OLV112A16A	0.99	1.04
EHD4X42A**	*9MX*0801716A**	0.99	1.03	ENH4X36*17**	OLV154F20A	1.00	1.04
ENH4X36*17**	*9MX*0801716A**	0.97	1.06	EHD4X42A**	OMV098J12A	0.99	1.04
ENH4X43*21**	*9MV*0601714A**	0.99	1.03	EN(A,D,W)4X42*21**	OMV112K14A	0.98	1.04
EA*4X36*17A*	*9MV*0801716A**	0.98	1.06	END4X42*17**	OMV112K14A	0.99	1.04
EA*4X42*21A*	*9MV*0801716A**	0.98	1.04	ENH4X42*21**	OMV112K14A	0.98	1.04
ENH4X42*21**	*9MV*0801716A**	0.98	1.04	ED*4X36B**	MV08B15**B*	0.98	1.04
EA*4X36*21A*	*9MV*1002120A**	0.97	1.03	ED*4X36J**	*9MPV100	0.99	1.04
EHD4X42A**	*9MV*1002120A**	0.98	1.01	ED*4X42F**	*8MPV075	0.99	1.04
ED*4X36F**	*9MA*0601714A**	0.97	1.08	EHD4X36A**	*9MPV075	0.99	1.04
EN(A,D,W)4X36*17**	*9MA*0601714A**	0.97	1.08	EHD4X36A**	*9MAC0602120A**	0.98	1.04
EA*4X36*21A*	*9MA*0801714A**	0.97	1.06	EHD4X42A**	*9MPV075	0.99	1.04
ENH4X43*21**	*9MA*0801714A**	0.98	1.01	EN(A,D)4X37*17**	-	1.02	1.04
EHD4X36A**	*9MA*0802120A**	0.98	1.02	EN(A,D)4X43*24**	-	1.02	1.04
EN(A,D)4X36*21**	*9MA*1002122A**	0.97	1.05	EN(A,D,W)4X42*21**	*9MPV100	0.99	1.04
ED*4X36F**	NOMV106D12*	0.97	1.06	ENH4X42*21**	*9MPV100	0.99	1.04
FEM4P42**A*	-	1.00	1.01	ENH4X42*21**	NOMV106D12*	0.98	1.05
FS(M,U)4P42**A*	-	1.01	1.05	EN(A,D)4X36*21**	NOMV156E19*	0.97	1.05
FVM4X48****	-	0.99	0.98	EHD4X42A**	*9MVX040	0.99	1.05
FXM4X42**A*	-	0.99	0.99	EN(A,D)4X37*17**	*9MVX040	1.01	1.05
ENH4X36*17**	*8MX*0701716**	0.98	1.07	END4X42*17**	*9MVX060	1.00	1.05
EHD4X42A**	*8MX*0902116**	0.99	0.99	EN(A,D)4X36*21**	*9MVX080	0.99	1.05
EHD4X42A**	*8MX*1102120**	0.99	0.99	EA*4X36*21A*	*9MV*1002116A**	0.98	1.05

HEATING Multiplying Factors for other Indoor Combinations

Indoor Model	Furnace Model	CAPACITY (MBh)	Power (AMPS)	Indoor Model	Furnace Model	CAPACITY (MBh)	Power (AMPS)
ENH4X36*17**	*8MX*1102120**	0.98	1.04	ED*4X36F**	*9MV*1002116A**	0.98	1.05
ENH4X42*21**	*8MX*1102120**	0.98	1.01	ED*4X36J**	*9MV*1002116A**	0.98	1.05
EN(A,D,W)4X36*17**	*8MV*0901716**	0.97	1.05	EA*4X36*21A*	*9MA*1002120A**	0.97	1.05
ENH4X42*21**	*8MV*0901716**	0.98	1.03	ED*4X36F**	*9MA*1002120A**	0.97	1.05
EA*4X36*21A*	*8MV*1102120**	0.97	1.04	ED*4X36J**	*9MA*1002120A**	0.97	1.05
EN(A,D,W)4X42*21**	*8MV*1102120**	0.98	1.03	EN(A,D,W)4X42*21**	*9MA*1002120A**	0.98	1.05
ENH4X42*21**	*8MV*1102120**	0.98	1.03	ENH4X42*21**	*9MA*1002120A**	0.98	1.05
EHD4X42A**	*8MV*1352422**	0.98	1.00	EHD4X36A**	OLV098A12A	0.99	1.05
EA*4X42*21A*	*9MX*0601714A**	0.99	1.05	END4X42*17**	OLV098A12A	0.99	1.05
EHD4X42A**	*9MX*0601714A**	0.99	1.03	ED*4X36J**	OLV112A16A	0.98	1.05
EN(A,D)4X36*21**	*9MX*0601714A**	0.98	1.07	ED*4X42F**	OLV112A16A	0.99	1.05
END4X42*17**	*9MX*0801716A**	0.98	1.04	EHD4X36A**	OMV098J12A	0.99	1.05
EA*4X42*21A*	*9MV*0601714A**	0.99	1.06	END4X42*17**	OMV098J12A	0.99	1.05
EN(A,D)4X36*21**	*9MV*0601714A**	0.98	1.08	ED*4X42F**	OMV112K14A	0.98	1.05
EN(A,D)4X37*17**	*9MV*0801716A**	0.99	1.01	EA*4X42*21A*	*9MAC0602120A**	0.97	1.05
EA*4X36*21A*	*9MV*0802120A**	0.97	1.04	ED*4X36F**	*8MPV075	0.99	1.05
EN(A,D,W)4X42*21**	*9MA*0601714A**	0.98	1.06	EHD4X42A**	-	1.01	1.05
END4X42*17**	*9MA*0601714A**	0.98	1.06	EHD4X42A**	*8MPV050	0.99	1.05
EA*4X36*17A*	*9MA*0801714A**	0.97	1.06	EHD4X42A**	*9MPV050	0.99	1.05
ENH4X36*17**	*9MA*0801714A**	0.97	1.07	EN(A,D)4X36*21**	*9MPV100	0.99	1.05
EA*4X36*21A*	*9MA*0802120A**	0.97	1.03	EN(A,D)4X37*17**	*9MPV050	1.01	1.05
EN(A,D,W)4X42*21**	*9MA*1002122A**	0.98	1.03	EN(A,D,W)4X42*21**	*9MAC0602120A**	0.98	1.05
ED*4X42L**	*9MA*1202422A**	0.97	1.03	END4X42*17**	*9MPV075	0.99	1.05
EHD4X36A**	NOMV106D12*	0.98	1.04	ENH4X42*21**	*9MAC0602120A**	0.98	1.05
FS(M,U)4X42****	-	1.02	1.09	ENH4X36*17**	NOMV156E19*	0.98	1.06
FVM4X36****	-	0.97	1.02	EHD4X36A**	*9MVX040	0.99	1.06
EA*4X36*17A*	*8MX*0701716**	0.98	1.06	ED*4X42F**	*9MVX060	0.99	1.06
END4X42*17**	*8MX*0701716**	0.99	1.05	EN(A,D,W)4X42*21**	*9MVX060	0.99	1.06
EA*4X36*21A*	*8MX*0902116**	0.98	1.02	ENH4X42*21**	*9MVX060	0.99	1.06
ENH4X42*21**	*8MV*0701412**	0.98	1.05	EN(A,D)4X36*21**	*9MV*1002116A**	0.98	1.06
EHD4X36A**	*8MV*0901716**	0.98	1.02	ENH4X36*17**	*9MV*1002116A**	0.98	1.06
EHD4X42A**	*8MV*1102120**	0.98	1.00	EN(A,D)4X36*21**	*9MA*1002120A**	0.97	1.06
EHD4X36A**	*8MV*1352422**	0.98	1.01	ED*4X42F**	OLV098A12A	0.98	1.06
EHD4X36A**	*9MX*0601714A**	0.99	1.04	ED*4X36F**	OLV112A16A	0.99	1.06
ENH4X36*17**	*9MX*0601714A**	0.98	1.08	EN(A,D)4X36*21**	OLV112A16A	0.99	1.06

HEATING Multiplying Factors for other Indoor Combinations

Indoor Model	Furnace Model	CAPACITY (MBh)	Power (AMPS)	Indoor Model	Furnace Model	CAPACITY (MBh)	Power (AMPS)
EN(A,D,W)4X42*21**	*9MX*0801716A**	0.98	1.05	ED*4X42F**	OMV098J12A	0.99	1.06
EA*4X36*21A*	*9MV*0601714A**	0.98	1.06	EN(A,D,W)4X42*21**	OMV098J12A	0.99	1.06
ED*4X42F**	*9MV*0601714A**	0.99	1.06	ENH4X42*21**	OMV098J12A	0.99	1.06
EHD4X42A**	*9MV*0601714A**	0.99	1.04	ED*4X36F**	OMV112K14A	0.98	1.06
END4X42*17**	*9MV*0601714A**	0.99	1.05	EN(A,D)4X36*21**	OMV112K14A	0.98	1.06
ENH4X42*21**	*9MV*0601714A**	0.99	1.06	EN(A,D,W)4X36*17**	OMV112K14A	0.98	1.06
EA*4X36*21A*	*9MV*0801716A**	0.98	1.05	ENH4X36*17**	OMV112K14A	0.98	1.06
EHD4X42A**	*9MV*0801716A**	0.99	1.02	EA*4X36*21A*	*9MAC0602120A**	0.97	1.06
ED*4X36F**	*9MA*0601714A**	0.97	1.08	EHD4X36A**	*9MPV050	0.99	1.06
FEA4X36**A*	-	1.01	1.10	EN(A,D,W)4X36*17**	NOMV106D12*	0.97	1.07
FEM4P36**A*	-	0.99	1.06	ENH4X36*17**	NOMV106D12*	0.97	1.07
EHD4X36A**	*8MX*0451408**	1.00	1.06	END4X42*17**	*9MVX040	1.00	1.07
ENH4X42*21**	*8MX*0451408**	0.99	1.07	ED*4X36F**	*9MVX060	0.99	1.07
ENH4X36*17**	*8MV*1102120**	0.97	1.05	ENH4X36*17**	*9MA*1002120A**	0.98	1.07
EA*4X36*21A*	*9MX*0601714A**	0.98	1.06	EN(A,D,W)4X42*21**	OLV098A12A	0.99	1.07
ED*4X36F**	*9MX*0601714A**	0.98	1.06	ENH4X42*21**	OLV098A12A	0.99	1.07
EA*4X36*17A*	*9MX*0801716A**	0.98	1.06	ENH4X36*17**	OLV112A16A	0.99	1.07
EN(A,D,W)4X42*21**	*9MV*1002120A**	0.98	1.04	ED*4X42F**	*9MPV075	0.99	1.07
ENH4X42*21**	*9MV*1202422A**	0.98	1.03	EHD4X36A**	-	1.01	1.07
ENH4X43*21**	*9MV*1202422A**	0.98	0.99	EHD4X36A**	*8MPV050	0.99	1.07
ENH4X42*21**	*9MA*0801714A**	0.98	1.05	EN(A,D)4X36*21**	*9MAC0602120A**	0.97	1.07
EHD4X42A**	*9MA*1002122A**	0.98	1.00	EN(A,D,W)4X42*21**	*9MPV075	0.99	1.07
EA*4X42*24A*	*9MA*1202422A**	0.97	1.03	END4X42*17**	*9MPV050	1.00	1.07
ENH4X43*21**	*9MA*1202422A**	0.98	0.99	ENH4X42*21**	*9MPV075	0.99	1.07
FVM4X24****	-	0.98	1.04	ED*4X42F**	*9MVX040	0.99	1.08
ED*4X36B**	*8MX*0451408**	0.99	1.09	EN(A,D,W)4X42*21**	*9MVX040	0.99	1.08
ENH4X36*17**	*8MX*0451408**	0.99	1.09	ENH4X42*21**	*9MVX040	0.99	1.08
EHD4X42A**	*8MX*0701716**	0.99	1.03	EN(A,D)4X36*21**	*9MVX060	0.99	1.08
EN(A,D,W)4X36*17**	*8MX*0701716**	0.98	1.07	EN(A,D,W)4X36*17**	*9MVX060	0.99	1.08
ENH4X42*21**	*8MX*0701716**	0.99	1.05	ENH4X36*17**	*9MVX060	0.99	1.08
ED*4X42L**	*8MV*1352422**	0.97	1.02	ED*4X36F**	OLV098A12A	0.98	1.08
ENH4X36*17**	*8MV*1352422**	0.97	1.05	EN(A,D)4X36*21**	OLV098A12A	0.98	1.08
EN(A,D,W)4X36*17**	*9MX*0801716A**	0.97	1.06	ED*4X36F**	OMV098J12A	0.98	1.08
EHD4X36A**	*9MV*0802120A**	0.98	1.02	ED*4X36F**	*9MPV075	0.99	1.08
EHD4X36A**	*9MV*1002120A**	0.98	1.01	ED*4X42F**	-	1.00	1.08

HEATING Multiplying Factors for other Indoor Combinations

Indoor Model	Furnace Model	CAPACITY (MBh)	Power (AMPS)	Indoor Model	Furnace Model	CAPACITY (MBh)	Power (AMPS)
EN(A,D)4X36*21**	*9MV*1002120A**	0.97	1.05	ED*4X42F**	*9MPV050	0.99	1.08
EA*4X42*21A*	*9MA*1002122A**	0.97	1.02	EN(A,D,W)4X42*21**	-	1.01	1.08
EHD4X36A**	*9MA*1002122A**	0.98	1.02	EN(A,D,W)4X42*21**	*9MPV050	0.99	1.08
ENH4X42*21**	*9MA*1002122A**	0.98	1.03	END4X42*17**	-	1.02	1.08
ENH4X36*17**	*9MA*1202422A**	0.97	1.06	ENH4X42*21**	-	1.01	1.08
ENH4X42*21**	*9MA*1202422A**	0.98	1.04	ENH4X42*21**	*9MPV050	0.99	1.08
FSU4X36****	-	1.01	1.11	ED*4X36F**	*9MVX040	0.99	1.09
EA*4X36*17A*	*9MX*0601714A**	0.98	1.06	EN(A,D,W)4X36*17**	OLV098A12A	0.98	1.09
ED*4X36F**	*9MX*0601714A**	0.98	1.06	ENH4X36*17**	OLV098A12A	0.98	1.09
ENH4X42*21**	*9MX*0801716A**	0.98	1.05	EN(A,D)4X36*21**	OMV098J12A	0.99	1.09
EA*4X36*17A*	*9MV*0601714A**	0.98	1.07	EN(A,D,W)4X36*17**	OMV098J12A	0.99	1.09
ED*4X36F**	*9MV*0601714A**	0.98	1.07	ENH4X36*17**	OMV098J12A	0.99	1.09
EN(A,D,W)4X36*17**	*9MV*0801716A**	0.98	1.06	EA*4X42*21A*	-	1.01	1.09
EN(A,D,W)4X42*21**	*9MV*0801716A**	0.98	1.04	EA*4X42*24A*	-	1.01	1.09
EA*4X42*21A*	*9MV*0802120A**	0.98	1.03	ED*4X36F**	*9MPV050	0.99	1.09
EA*4X42*24A*	*9MV*1202422A**	0.98	1.02	ED*4X42J**	-	1.01	1.09
EHD4X42A**	*9MV*1202422A**	0.98	1.00	ED*4X42L**	-	1.01	1.09
END4X42*17**	*9MA*0801714A**	0.98	1.04	EN(A,D)4X36*21**	*9MPV075	0.99	1.09
EA*4X36*21A*	*9MA*1002122A**	0.97	1.04	EN(A,D,W)4X36*17**	*9MPV075	0.99	1.09
EN(A,D)4X43*24**	*9MA*1202422A**	0.98	0.99	ENH4X36*17**	*9MPV075	0.99	1.09
FVM4X60****	-	0.98	0.94	EN(A,D)4X36*21**	*9MVX040	0.99	1.10
EA*4X36*14A*	*8MX*0451408**	0.99	1.09	EN(A,D,W)4X36*17**	*9MVX040	0.99	1.10
EHD4X42A**	*8MX*0451408**	1.01	1.05	ENH4X36*17**	*9MVX040	0.99	1.10
ED*4X42F**	*9MV*0801716A**	0.98	1.05	EA*4X36*14A*	-	1.00	1.10
EHD4X36A**	*9MV*0801716A**	0.99	1.03	EA*4X36*17A*	-	1.01	1.10
EN(A,D)4X36*21**	*9MV*0801716A**	0.98	1.06	EA*4X36*21A*	-	1.01	1.10
END4X42*17**	*9MV*0801716A**	0.99	1.04	ED*4X36B**	-	1.00	1.10
ENH4X43*21**	*9MV*0801716A**	0.99	1.01	ED*4X36F**	-	1.01	1.10
EN(A,D)4X36*21**	*9MV*0802120A**	0.97	1.05	ED*4X36J**	-	1.01	1.10
EN(A,D)4X37*17**	*9MA*0801714A**	0.99	1.01	EMA4X36D**	-	1.01	1.10
EN(A,D,W)4X36*17**	*9MA*0801714A**	0.97	1.07	EN(A,D)4X36*21**	-	1.01	1.10
EN(A,D,W)4X42*21**	*9MA*0801714A**	0.98	1.05	EN(A,D)4X36*21**	*9MPV050	0.99	1.10
EN(A,D,W)4X42*21**	*9MA*0802120A**	0.97	1.03	EN(A,D,W)4X36*17**	-	1.01	1.10
ENH4X42*21**	*9MA*0802120A**	0.97	1.03	EN(A,D,W)4X36*17**	*9MPV050	0.99	1.10
EHD4X36A**	*9MA*1202422A**	0.98	1.02	ENH4X36*17**	-	1.01	1.10

HEATING Multiplying Factors for other Indoor Combinations						
Indoor Model	Furnace Model	CAPACITY (MBh)	Power (AMPS)	Indoor Model	Furnace Model	Power (AMPS)
EHD4X42A**	*9MA*1202422A**	0.98	1.01	ENH4X36*17**	*9MPV050	1.10
ENH4X36*17**	*9MV*0801716A**	0.98	1.06	ED*4X36B**	*8MPV050	1.11
HEATING Multiplying Factors for other Indoor Combinations						
Indoor Model	Furnace Model	CAPACITY (MBh)	Power (AMPS)	Indoor Model	Furnace Model	Power (AMPS)
<b>NXH537</b>						
*FXM4X36**A*	-	1.00	1.00	ENH4X42*21**	*9MVX040	1.09
ED*4X36B**	*8MPV050	0.99	1.12	EN(A,D)4X43*24**	*9MVX100	0.98
ED*4X36F**	*8MPV075	0.98	1.05	EHD4X42A**	MV08B15**B*	1.00
ED*4X36F**	*9MPV050	0.99	1.10	EHD4X36A**	OMV098J12A	1.05
ED*4X36F**	*9MPV075	0.98	1.08	ENH4X42*21**	OMV098J12A	1.07
ED*4X36F**	*9MVX040	0.99	1.10	EN(A,D)4X43*24**	-	1.03
ED*4X36J**	*8MPV100	0.99	1.03	EHD4X42A**	MV12F19**B*	0.99
ED*4X36J**	*8MPV125	0.98	1.01	EHD4X42A**	MV16J22**B*	0.98
ED*4X36J**	*9MPV100	0.99	1.04	EN(A,D,W)4X36*17**	OMV112K14A	1.07
ED*4X42F**	*8MPV075	0.99	1.04	ENH4X36*17**	MV08B15**B*	1.04
ED*4X42F**	*9MPV050	0.99	1.08	EHD4X42A**	OMV098J12A	1.04
ED*4X42F**	*9MPV075	0.99	1.07	ENH4X43*21**	OMV098J12A	1.02
ED*4X42F**	*9MVX040	0.99	1.09	EN(A,D,W)4X36*17**	-	1.10
ED*4X42J**	*8MPV100	0.99	1.02	ENH4X36*17**	MV12F19**B*	1.02
ED*4X42J**	*8MPV125	0.99	1.01	ENH4X36*17**	MV16J22**B*	1.02
ED*4X42J**	*9MPV100	0.99	1.03	EN(A,D,W)4X42*21**	OMV112K14A	1.05
ED*4X42L**	*8MV*1352422**	0.97	1.02	ED*4X36F**	OLV098A12A	1.08
EHD4X36A**	*9MPV125	0.99	1.02	ED*4X42J**	-	1.08
EHD4X36A**	*8MPV050	1.00	1.08	ENH4X36*17**	*9MVX100	1.05
EHD4X36A**	*8MPV075	0.99	1.03	ENH4X42*21**	MV08B15**B*	1.02
EHD4X36A**	*8MPV100	1.00	1.02	ENH4X42*21**	MV12F19**B*	1.01
EHD4X36A**	*8MPV125	0.99	1.00	ENH4X42*21**	MV16J22**B*	1.00
EHD4X36A**	*8MV*0701412**	0.98	1.04	EN(A,D)4X43*24**	MV20L24**B*	0.96
EHD4X36A**	*8MV*0901716**	0.98	1.02	ED*4X42F**	NOMV106D12*	-
EHD4X36A**	*8MV*1102120**	0.98	1.01	ED*4X42J**	NOMV156E19*	1.04
EHD4X36A**	*8MV*1352422**	0.98	1.01	ED*4X42F**	OLV098A12A	1.07
EHD4X36A**	*8MX*0451408**	1.00	1.07	EN(A,D,W)4X42*21**	OLV098A12A	1.07
EHD4X36A**	*8MX*0701716**	0.99	1.04	ED*4X36F**	OLV112A16A	1.06
EHD4X36A**	*8MX*0902116**	0.98	1.01	EN(A,D)4X43*24**	OLV112A16A	0.99

HEATING Multiplying Factors for other Indoor Combinations

Indoor Model	Furnace Model	CAPACITY (MBh)	Power (AMPS)	Indoor Model	Furnace Model	CAPACITY (MBh)	Power (AMPS)
EHD4X36A**	*8MX*1102120**	0.98	1.00	EHD4X42A**	OLV154F20A	1.00	0.98
EHD4X36A**	*9MPV050	1.00	1.07	EN(A,D)4X36*21**	OMV098J12A	0.99	1.08
EHD4X36A**	*9MPV075	0.99	1.05	ED*4X36F**	OMV112K14A	0.98	1.06
EHD4X36A**	*9MPV100	1.00	1.03	END4X42*17**	OMV112K14A	0.99	1.03
EHD4X36A**	*9MPV125	0.99	1.02	ED*4X42L**	-	1.01	1.09
EHD4X36A**	*9MVX040	1.00	1.08	EN(A,D,W)4X42*21**	-	1.00	1.08
EHD4X42A**	*8MPV050	1.00	1.07	ENH4X42*21**	*9MVX100	0.98	1.03
EHD4X42A**	*8MPV075	1.00	1.02	ENH4X43*21**	MV08B15**B*	0.99	0.98
EHD4X42A**	*8MPV100	1.00	1.00	ENH4X43*21**	MV12F19**B*	0.98	0.97
EHD4X42A**	*8MPV125	1.00	0.99	ENH4X43*21**	MV16J22**B*	0.98	0.96
EHD4X42A**	*8MV*0701412**	0.98	1.03	ENH4X36*17**	MV20L24**B*	0.97	1.02
EHD4X42A**	*8MV*0901716**	0.98	1.01	EN(A,D)4X37*17**	NOMV106D12*	0.98	1.01
EHD4X42A**	*8MV*1102120**	0.98	1.01	ED*4X42L**	NOMV156E19*	-	-
EHD4X42A**	*8MV*1352422**	0.98	1.00	EHD4X36A**	OLV098A12A	0.99	1.05
EHD4X42A**	*8MX*0451408**	1.00	1.05	END4X42*17**	OLV098A12A	0.99	1.06
EHD4X42A**	*8MX*0701716**	0.99	1.03	ED*4X36J**	OLV112A16A	0.99	1.05
EHD4X42A**	*8MX*0902116**	0.99	1.00	EN(A,D,W)4X42*21**	OLV112A16A	0.99	1.05
EHD4X42A**	*8MX*1102120**	0.99	0.99	EN(A,D)4X43*24**	OLV154F20A	1.00	0.95
EHD4X42A**	*9MPV050	1.00	1.06	EN(A,D)4X37*17**	OMV098J12A	1.00	1.03
EHD4X42A**	*9MPV075	1.00	1.05	ED*4X42F**	OMV112K14A	0.98	1.04
EHD4X42A**	*9MPV100	1.00	1.01	ENH4X36*17**	OMV112K14A	0.98	1.07
EHD4X42A**	*9MPV125	1.00	1.01	EHD4X36A**	-	1.00	1.06
EHD4X42A**	*9MVX040	1.00	1.06	END4X42*17**	-	1.00	1.07
EN(A,D)4X36*21**	*8MV*1102120**	0.97	1.05	EN(A,D)4X36*21**	NOMV156E19*	0.97	1.05
EN(A,D)4X36*21**	*8MX*0902116**	0.97	1.04	ENH4X36*17**	OLV112A16A	0.99	1.07
EN(A,D)4X36*21**	*8MX*1102120**	0.97	1.04	ENH4X36*17**	OLV154F20A	1.00	1.04
EN(A,D)4X36*21**	*9MPV100	0.99	1.05	ENH4X42*21**	OMV112K14A	0.99	1.05
EN(A,D)4X37*17**	*8MV*0901716**	0.98	0.99	EN(A,D,W)4X36*17**	NOMV106D12*	0.97	1.07
EN(A,D)4X37*17**	*8MX*0701716**	1.00	1.02	ED*4X42F**	OLV112A16A	0.99	1.05
EN(A,D)4X37*17**	*9MPV050	1.00	1.03	EN(A,D,W)4X36*17**	OMV098J12A	0.99	1.09
EN(A,D)4X37*17**	*9MPV075	1.00	1.02	EHD4X36A**	OMV112K14A	0.99	1.03
EN(A,D)4X37*17**	*9MVX040	1.00	1.04	ENH4X36*17**	-	1.00	1.10
EN(A,D)4X43*24**	*8MV*1352422**	0.98	0.98	EHD4X42A**	OLV098A12A	0.99	1.04
EN(A,D)4X43*24**	*9MPV100	1.00	0.97	ENH4X43*21**	OMV112K14A	1.00	1.01
EN(A,D)4X43*24**	*9MPV125	1.00	0.97	EHD4X42A**	-	1.00	1.05

HEATING Multiplying Factors for other Indoor Combinations

Indoor Model	Furnace Model	CAPACITY (MBh)	Power (AMPS)	Indoor Model	Furnace Model	CAPACITY (MBh)	Power (AMPS)
EN(A,D,W)4X36*17**	*8MV*0901716**	0.97	1.05	END4X42*17**	NOMV106D12*	0.98	1.04
EN(A,D,W)4X36*17**	*8MX*0701716**	0.98	1.07	ED*4X42J**	OLV112A16A	0.99	1.04
EN(A,D,W)4X42*21**	*8MV*1102120**	0.97	1.03	EN(A,D,W)4X42*21**	NOMV156E19*	0.97	1.04
EN(A,D,W)4X42*21**	*8MX*0902116**	0.98	1.03	ENH4X42*21**	OLV112A16A	0.99	1.05
EN(A,D,W)4X42*21**	*8MX*1102120**	0.98	1.01	ENH4X42*21**	OLV154F20A	1.00	1.01
EN(A,D,W)4X42*21**	*9MPV100	1.00	1.04	ED*4X36B**	-	1.00	1.11
END4X42*17**	*8MV*0901716**	0.98	1.03	ENH4X36*17**	NOMV106D12*	0.97	1.07
END4X42*17**	*8MX*0701716**	0.99	1.05	ED*4X42L**	OLV112A16A	0.99	1.04
ENH4X36*17**	*8MPV050	0.98	1.10	ENH4X43*21**	*9MVX100	1.00	0.98
ENH4X36*17**	*8MPV075	0.98	1.07	ED*4X36F**	MV12F19**B*	0.97	1.02
ENH4X36*17**	*8MPV100	0.98	1.04	ED*4X36J**	MV16J22**B*	0.97	1.01
ENH4X36*17**	*8MPV125	0.98	1.04	ED*4X42L**	MV20L24**B*	0.97	1.00
ENH4X36*17**	*8MV*0701412**	0.97	1.07	ENH4X42*21**	MV20L24**B*	0.97	1.01
ENH4X36*17**	*8MV*0901716**	0.97	1.05	ENH4X42*21**	NOMV106D12*	0.97	1.05
ENH4X36*17**	*8MV*1102120**	0.97	1.05	ENH4X36*17**	NOMV156E19*	0.97	1.06
ENH4X36*17**	*8MV*1352422**	0.97	1.04	EN(A,D)4X36*21**	OLV098A12A	0.98	1.08
ENH4X36*17**	*8MX*0451408**	0.99	1.10	ENH4X36*17**	OLV098A12A	0.98	1.08
ENH4X36*17**	*8MX*0701716**	0.98	1.07	EHD4X36A**	OLV112A16A	1.00	1.04
ENH4X36*17**	*8MX*0902116**	0.97	1.04	ENH4X43*21**	OLV112A16A	1.00	1.00
ENH4X36*17**	*8MX*1102120**	0.97	1.04	ENH4X43*21**	OLV154F20A	1.00	0.96
ENH4X36*17**	*9MPV050	0.99	1.10	EN(A,D,W)4X42*21**	OMV098J12A	0.99	1.07
ENH4X36*17**	*9MPV075	0.98	1.09	EHD4X42A**	OMV112K14A	0.99	1.03
ENH4X36*17**	*9MPV100	0.98	1.06	ED*4X36F**	-	1.00	1.10
ENH4X36*17**	*9MPV125	0.98	1.05	EMA4X36D**	-	1.00	1.10
ENH4X36*17**	*9MVX040	0.99	1.11	ENH4X42*21**	-	1.01	1.09
ENH4X42*21**	*8MPV050	0.99	1.09	ED*4X36B**	MV08B15**B*	0.98	1.04
ENH4X42*21**	*8MPV075	0.99	1.04	ED*4X42F**	MV12F19**B*	0.97	1.01
ENH4X42*21**	*8MPV100	0.99	1.03	ED*4X42J**	MV16J22**B*	0.97	1.00
ENH4X42*21**	*8MPV125	0.99	1.02	EHD4X36A**	MV20L24**B*	0.98	0.99
ENH4X42*21**	*8MV*0701412**	0.98	1.05	ENH4X43*21**	MV20L24**B*	0.98	0.97
ENH4X42*21**	*8MV*0901716**	0.97	1.03	ENH4X43*21**	NOMV106D12*	0.98	1.01
ENH4X42*21**	*8MV*1102120**	0.97	1.03	ENH4X42*21**	NOMV156E19*	0.97	1.04
ENH4X42*21**	*8MV*1352422**	0.97	1.03	EN(A,D)4X37*17**	OLV098A12A	1.00	1.03
ENH4X42*21**	*8MX*0451408**	0.99	1.08	ENH4X42*21**	OLV098A12A	0.99	1.07
ENH4X42*21**	*8MX*0701716**	0.98	1.05	EHD4X42A**	OLV112A16A	1.00	1.02



HEATING Multiplying Factors for other Indoor Combinations

Indoor Model	Furnace Model	CAPACITY (MBh)	Power (AMPS)	Indoor Model	Furnace Model	CAPACITY (MBh)	Power (AMPS)
ENH4X42*21**	*8MX*0902116**	0.98	1.03	ED*4X42L**	OLV154F20A	1.00	1.01
ENH4X42*21**	*8MX*1102120**	0.98	1.01	ED*4X36F**	OMV098J12A	0.99	1.08
ENH4X42*21**	*9MPV050	0.99	1.08	END4X42*17**	OMV098J12A	0.99	1.05
ENH4X42*21**	*9MPV075	0.99	1.07	EN(A,D)4X36*21**	OMV112K14A	0.98	1.07
ENH4X42*21**	*9MPV100	0.99	1.04	ED*4X36J**	-	1.00	1.10
ENH4X42*21**	*9MPV125	0.99	1.03	EN(A,D)4X36*21**	-	1.00	1.10
ENH4X43*21**	*8MPV050	1.00	1.04	EHD4X36A**	MV08B15**B*	0.98	1.01
ENH4X43*21**	*8MPV075	1.00	1.00	EHD4X36A**	MV12F19**B*	0.98	0.99
ENH4X43*21**	*8MPV100	1.00	0.97	EHD4X36A**	MV16J22**B*	0.98	0.99
ENH4X43*21**	*8MPV125	1.00	0.97	EHD4X42A**	MV20L24**B*	0.98	0.99
ENH4X43*21**	*8MV*0701412**	0.99	1.01	ED*4X36F**	NOMV106D12*	0.97	1.07
ENH4X43*21**	*8MV*0901716**	0.98	0.99	ED*4X36J**	NOMV156E19*	0.97	1.05
ENH4X43*21**	*8MV*1102120**	0.99	0.99	ENH4X43*21**	NOMV156E19*	0.98	1.00
ENH4X43*21**	*8MV*1352422**	0.98	0.98	EN(A,D,W)4X36*17**	OLV098A12A	0.98	1.08
ENH4X43*21**	*8MX*0451408**	1.00	1.03	ENH4X43*21**	OLV098A12A	1.00	1.03
ENH4X43*21**	*8MX*0701716**	1.00	1.02	EN(A,D)4X36*21**	OLV112A16A	0.99	1.07
ENH4X43*21**	*8MX*0902116**	0.99	0.98	EHD4X36A**	OLV154F20A	1.00	0.99
ENH4X43*21**	*8MX*1102120**	0.99	0.97	ED*4X42F**	OMV098J12A	0.99	1.07
ENH4X43*21**	*9MPV050	1.00	1.04	ENH4X36*17**	OMV098J12A	0.99	1.09
ENH4X43*21**	*9MPV075	1.00	1.02	EN(A,D)4X37*17**	OMV112K14A	1.00	1.01
ENH4X43*21**	*9MPV100	1.00	0.98	ED*4X42F**	-	1.00	1.08
ENH4X43*21**	*9MPV125	1.00	0.98	EN(A,D)4X37*17**	-	1.00	1.03
FEA4X36**A*	-	0.98	1.07	ENH4X43*21**	*9MVX040	1.00	1.04
FEM4P36**A*	-	0.99	1.07	ED*4X36F**	*9MVX060	0.99	1.07
FEM4P36**A*	-	0.99	1.07	ED*4X42F**	*9MVX060	0.99	1.07
FEM4P42**A*	-	1.00	1.02	EHD4X36A**	*9MVX060	1.00	1.05
FEM4P42**A*	-	1.00	1.02	EHD4X42A**	*9MVX060	1.00	1.04
FEM4P48**A*	-	-	-	EN(A,D)4X37*17**	*9MVX060	1.00	1.01
FEM4X36****	-	1.00	1.03	ENH4X36*17**	*9MVX060	0.98	1.08
FEM4X42****	-	1.00	1.03	ENH4X42*21**	*9MVX060	0.99	1.07
FS(M,U)4P36**A*	-	1.00	1.07	ENH4X43*21**	*9MVX060	1.00	1.02
FS(M,U)4P36**A*	-	1.00	1.07	ED*4X36J**	*9MVX080	1.00	1.05
FS(M,U)4P42**A*	-	1.00	1.05	ED*4X42J**	*9MVX080	1.00	1.03
FS(M,U)4P42**A*	-	1.00	1.04	EHD4X36A**	*9MVX080	1.00	1.02
FS(M,U)4X42****	-	1.02	1.10	EHD4X42A**	*9MVX080	1.00	1.01

HEATING Multiplying Factors for other Indoor Combinations

Indoor Model	Furnace Model	CAPACITY (MBh)	Power (AMPS)	Indoor Model	Furnace Model	CAPACITY (MBh)	Power (AMPS)
FSA4X36**A*	-	1.00	1.11	EN(A,D)4X36*21**	*9MVX080	0.99	1.05
FSM4X36****	-	1.00	1.07	EN(A,D)4X43*24**	*9MVX080	1.00	0.97
FSU4X36****	-	1.00	1.10	EN(A,D,W)4X42*21**	*9MVX080	1.00	1.03
FVM4X24****	-	0.98	1.04	ENH4X36*17**	*9MVX080	0.99	1.05
FVM4X36****	-	0.97	1.03	ENH4X42*21**	*9MVX080	0.99	1.03
FVM4X48****	-	0.98	0.98	ENH4X43*21**	*9MVX080	1.00	0.98
FVM4X60****	-	0.98	0.96	ED*4X42L**	*9MVX100	0.99	1.03
FXM4X42**A*	-	1.00	1.01	EHD4X36A**	*9MVX100	0.99	1.02
FXM4X48**A*	-	-	-	EHD4X42A**	*9MVX100	0.99	1.00
-	-	-	-	ENH4X43*21**	-	1.00	1.03

HEATING Multiplying Factors for other Indoor Combinations

Indoor Model	Furnace Model	CAPACITY (MBh)	Power (AMPS)	Indoor Model	Furnace Model	CAPACITY (MBh)	Power (AMPS)
<b>NXH542</b>							
*FXM4X42**A*	-	1.00	1.00	EHD4X48A**	*9MA*0802120A**	1.01	1.03
EA*4X42*21A*	*8MX*0902116**	1.01	1.04	ENH4X48*21**	*9MA*1202422A**	1.01	1.03
EA*4X42*21A*	*8MX*1102120**	1.01	1.04	ED*4X42F**	*9MVX060	1.01	1.08
EA*4X42*21A*	*8MV*1102120**	1.01	1.06	ED*4X48J**	*9MX*1002116A**	1.01	1.04
EA*4X42*21A*	*9MX*0601714A**	1.01	1.07	ED*4X48L**	*9MV*1002116A**	1.01	1.03
EA*4X42*21A*	*9MX*0801716A**	1.01	1.06	EA*4X48*24A*	*9MA*1002120A**	1.01	1.04
EA*4X42*21A*	*9MX*0802120A**	1.01	1.04	ENH4X43*21**	*9MA*1002120A**	1.01	1.01
EA*4X42*21A*	*9MX*1002120A**	1.01	1.05	EHD4X42A**	OLV112A16A	1.01	1.03
EA*4X42*21A*	*9MV*0601714A**	1.01	1.08	EHD4X42A**	OMV112K14A	1.01	1.03
EA*4X42*21A*	*9MV*0801716A**	1.01	1.07	EA*4X48*21A*	-	1.01	1.03
EA*4X42*21A*	*9MV*0802120A**	1.01	1.06	ED*4X42L**	MV20L24**B*	1.01	1.03
EA*4X42*21A*	*9MV*1002120A**	1.01	1.06	ED*4X48J**	*9MPV100	1.01	1.02
EA*4X42*21A*	*9MA*0601714A**	1.01	1.09	EHD4X48A**	*9MPV075	1.01	1.04
EA*4X42*21A*	*9MA*0801714A**	1.01	1.08	EN(A,D)4X48*24**	*9MPV125	1.01	1.01
EA*4X42*21A*	*9MA*0802120A**	1.00	1.06	ENH4X48*21**	-	1.01	1.03
EA*4X42*24A*	*8MX*1352420**	1.01	1.04	EN(A,D)4X43*24**	*9MVX080	1.01	0.98
EA*4X42*24A*	*8MV*1352422**	1.01	1.04	ENH4X48*21**	*9MX*1002116A**	1.01	1.03
EA*4X42*24A*	*9MX*1202422A**	1.01	1.04	ENH4X48*21**	OLV112A16A	1.01	1.03
EA*4X42*24A*	*9MV*1202422A**	1.01	1.05	EHD4X42A**	*8MPV125	1.01	1.00
EA*4X48*17A*	*8MX*0701716**	1.01	1.03	ED*4X48L**	*9MA*1202422A**	1.01	1.03
EA*4X48*17A*	*8MV*0901716**	1.01	1.01	ENH4X48*21**	*9MVX100	1.01	1.01

HEATING Multiplying Factors for other Indoor Combinations

Indoor Model	Furnace Model	CAPACITY (MBh)	Power (AMPS)	Indoor Model	Furnace Model	CAPACITY (MBh)	Power (AMPS)
EA*4X48*17A*	*9MX*0601714A**	1.01	1.03	EHD4X42A**	*9MV*1002116A**	1.01	1.03
EA*4X48*17A*	*9MX*0801716A**	1.01	1.02	ED*4X42J**	*9MA*1002120A**	1.01	1.07
EA*4X48*17A*	*9MV*0601714A**	1.01	1.04	EHD4X48A**	OMV112K14A	1.01	1.03
EA*4X48*17A*	*9MV*0801716A**	1.01	1.03	EA*4X48*24A*	-	1.01	1.03
EA*4X48*17A*	*9MA*0601714A**	1.01	1.05	EHD4X48A**	*9MPV100	1.01	1.01
EA*4X48*17A*	*9MA*0801714A**	1.01	1.04	EN(A,D,W)4X42*21**	-	1.01	1.06
EA*4X48*21A*	*8MX*0902116**	1.01	1.02	ED*4X42J**	NOMV156E19*	1.01	1.06
EA*4X48*21A*	*8MX*1102120**	1.01	1.01	ED*4X48F**	*9MVX060	1.01	1.03
EA*4X48*21A*	*8MV*1102120**	1.01	1.02	ED*4X48J**	*9MX*1002116A**	1.01	1.04
EA*4X48*21A*	*9MX*0601714A**	1.01	1.04	EHD4X48A**	*9MV*1002116A**	1.01	1.02
EA*4X48*21A*	*9MX*0801716A**	1.01	1.03	ED*4X42L**	*9MA*1002120A**	1.01	1.07
EA*4X48*21A*	*9MX*0802120A**	1.01	1.02	ENH4X48*21**	*9MA*1002120A**	1.01	1.04
EA*4X48*21A*	*9MV*0601714A**	1.01	1.02	EHD4X48A**	OLV112A16A	1.01	1.02
EA*4X48*21A*	*9MV*0801716A**	1.01	1.05	EN(A,D,W)4X42*21**	OMV112K14A	1.01	1.07
EA*4X48*21A*	*9MV*0802120A**	1.01	1.04	ED*4X42F**	-	1.01	1.07
EA*4X48*21A*	*9MV*0802120A**	1.01	1.03	ED*4X48F**	-	1.01	1.02
EA*4X48*21A*	*9MV*1002120A**	1.01	1.03	ED*4X48J**	MV16J22**B*	1.01	1.00
EA*4X48*21A*	*9MA*0601714A**	1.01	1.06	EHD4X48A**	*9MPV125	1.01	1.01
EA*4X48*21A*	*9MA*0801714A**	1.01	1.05	EN(A,D,W)4X42*21**	*9MPV100	1.01	1.05
EA*4X48*21A*	*9MA*0802120A**	1.01	1.04	ENH4X48*21**	*9MPV100	1.01	1.01
EA*4X48*24A*	*8MX*1352420**	1.01	1.01	EN(A,D)4X48*24**	*9MVX080	1.01	1.01
EA*4X48*24A*	*8MV*1352422**	1.01	1.01	EA*4X42*21A*	*9MV*1002116A**	1.01	1.06
EA*4X48*24A*	*9MX*1202422A**	1.01	1.01	ED*4X42L**	OLV154F20A	1.01	1.02
EA*4X48*24A*	*9MV*1202422A**	1.01	1.02	EHD4X42A**	*9MPV075	1.01	1.05
ED*4X42F**	*9MX*0601714A**	1.01	1.08	EN(A,D)4X43*24**	*9MV*1002116A**	1.01	1.01
ED*4X42F**	*9MX*0801716A**	1.01	1.07	ED*4X48J**	*9MA*1002120A**	1.01	1.04
ED*4X42F**	*9MV*0601714A**	1.01	1.09	EN(A,D,W)4X48*21**	OMV112K14A	1.01	1.03
ED*4X42F**	*9MV*0801716A**	1.01	1.08	ED*4X42F**	*8MPV075	1.01	1.07
ED*4X42F**	*9MA*0601714A**	1.01	1.10	EHD4X48A**	MV12F19**B*	1.01	0.99
ED*4X42F**	*9MA*0801714A**	1.01	1.09	EN(A,D,W)4X42*21**	*9MAC0602120A**	1.01	1.08
ED*4X42J**	*8MX*0902116**	1.01	1.04	ED*4X48J**	NOMV156E19*	1.01	1.03
ED*4X42J**	*8MX*1102120**	1.01	1.04	EHD4X42A**	*9MVX060	1.01	1.04
ED*4X42J**	*8MV*1102120**	1.01	1.06	ED*4X48L**	*9MX*1002116A**	1.01	1.03
ED*4X42J**	*9MV*1202422A**	1.01	1.06	EHD4X42A**	*9MPV100	1.01	1.02
ED*4X42L**	*8MX*1352420**	1.01	1.04	EN(A,D,W)4X42*21**	*9MVX080	1.01	1.05

HEATING Multiplying Factors for other Indoor Combinations

Indoor Model	Furnace Model	CAPACITY (MBh)	Power (AMPS)	Indoor Model	Furnace Model	CAPACITY (MBh)	Power (AMPS)
ED*4X42L**	*8MV*1352422**	1.00	1.03	EA*4X42*24A*	*9MV*1002116A**	1.01	1.06
ED*4X42L**	*9MX*1202422A**	1.01	1.04	ED*4X48L**	OLV154F20A	1.01	0.99
ED*4X42L**	*9MV*1202422A**	1.01	1.05	EHD4X42A**	*9MPV125	1.01	1.01
ED*4X48F**	*8MX*0701716**	1.01	1.03	EHD4X42A**	*9MA*1202422A**	1.01	1.03
ED*4X48F**	*8MV*0901716**	1.01	1.01	EA*4X42*21A*	*9MX*1002116A**	1.01	1.07
ED*4X48F**	*9MX*0601714A**	1.01	1.03	EN(A,D)4X48*24**	*9MV*1002116A**	1.01	1.02
ED*4X48F**	*9MX*0801716A**	1.01	1.02	ED*4X48J**	*9MA*1002120A**	1.01	1.04
ED*4X48F**	*9MV*0601714A**	1.01	1.04	END4X42*17**	OMV112K14A	1.01	1.06
ED*4X48F**	*9MV*0801716A**	1.01	1.03	ED*4X42F**	*9MPV075	1.01	1.09
ED*4X48F**	*9MA*0601714A**	1.01	1.05	EHD4X48A**	MV16J22**B*	1.01	0.99
ED*4X48F**	*9MA*0801714A**	1.01	1.04	EN(A,D,W)4X48*21**	-	1.01	1.03
ED*4X48J**	*8MX*0902116**	1.01	1.02	EHD4X42A**	NOMV156E19*	1.01	1.03
ED*4X48J**	*8MX*1102120**	1.01	1.01	EHD4X48A**	*9MVX060	1.01	1.03
ED*4X48J**	*8MV*1102120**	1.01	1.02	EHD4X42A**	*9MX*1002116A**	1.01	1.03
ED*4X48J**	*9MX*1202422A**	1.01	1.01	EHD4X42A**	OLV154F20A	1.01	1.00
ED*4X48J**	*9MV*1202422A**	1.01	1.03	EHD4X42A**	MV12F19**B*	1.01	1.00
ED*4X48L**	*8MX*1352420**	1.01	1.01	EN(A,D,W)4X48*21**	*9MVX080	1.01	1.01
ED*4X48L**	*8MV*1352422**	1.01	1.01	EA*4X48*21A*	*9MV*1002116A**	1.01	1.03
ED*4X48L**	*9MX*1202422A**	1.01	1.01	EHD4X48A**	OLV154F20A	1.01	0.99
ED*4X48L**	*9MV*1202422A**	1.01	1.02	EHD4X42A**	MV16J22**B*	1.01	1.00
EHD4X42A**	*8MX*0701716**	1.01	1.04	EHD4X48A**	*9MA*1202422A**	1.01	1.02
EHD4X42A**	*8MX*0902116**	1.01	1.02	EHD4X48A**	NOMV156E19*	1.01	1.02
EHD4X42A**	*8MX*1102120**	1.01	1.01	EN(A,D,W)4X42*21**	*9MVX060	1.01	1.08
EHD4X42A**	*8MV*1352420**	1.01	1.02	ENH4X42*21**	*9MVX080	1.01	1.05
EHD4X42A**	*8MV*0701412**	1.01	1.04	EHD4X48A**	*9MVX100	1.01	1.01
EHD4X42A**	*8MV*0901716**	1.01	1.02	EA*4X42*24A*	*9MX*1002116A**	1.01	1.06
EHD4X42A**	*8MV*1102120**	1.01	1.02	EHD4X48A**	*9MX*1002116A**	1.01	1.03
EHD4X42A**	*8MV*1352422**	1.01	1.01	EA*4X48*24A*	*9MV*1002116A**	1.01	1.03
EHD4X42A**	*9MX*0601714A**	1.01	1.04	EN(A,D,W)4X42*21**	*9MV*1002116A**	1.01	1.06
EHD4X42A**	*9MX*0801716A**	1.01	1.03	ED*4X48L**	*9MA*1002120A**	1.01	1.04
EHD4X42A**	*9MX*0802120A**	1.01	1.02	ED*4X42F**	OLV112A16A	1.01	1.07
EHD4X42A**	*9MX*1002120A**	1.01	1.02	EN(A,D)4X43*24**	OLV112A16A	1.01	1.00
EHD4X42A**	*9MX*1202422A**	1.01	1.01	EN(A,D)4X43*24**	OLV154F20A	1.01	0.97
EHD4X42A**	*9MV*0601714A**	1.01	1.05	ENH4X42*21**	OMV112K14A	1.01	1.07
EHD4X42A**	*9MV*0801716A**	1.01	1.04	ED*4X42F**	MV12F19**B*	1.01	1.04

HEATING Multiplying Factors for other Indoor Combinations

Indoor Model	Furnace Model	CAPACITY (MBh)	Power (AMPS)	Indoor Model	Furnace Model	CAPACITY (MBh)	Power (AMPS)
EHD4X42A**	*9MV*0802120A**	1.01	1.02	ED*4X48F**	*8MPV075	1.01	1.02
EHD4X42A**	*9MV*1002120A**	1.01	1.02	ED*4X48L**	-	1.01	1.03
EHD4X42A**	*9MA*0601714A**	1.01	1.06	EHD4X48A**	MV20L24**B*	1.01	0.99
EHD4X42A**	*9MA*0801714A**	1.01	1.05	EN(A,D,W)4X48*21**	*9MPV100	1.01	1.01
EHD4X42A**	*9MA*0802120A**	1.01	1.03	ENH4X48*21**	*9MPV125	1.01	1.01
EHD4X48A**	*8MX*0701716**	1.01	1.03	EN(A,D)4X43*24**	*9MA*1202422A**	1.01	1.00
EHD4X48A**	*8MX*0902116**	1.01	1.01	EN(A,D,W)4X42*21**	NOMV156E19*	1.01	1.06
EHD4X48A**	*8MX*1102120**	1.01	1.00	END4X42*17**	*9MVX060	1.01	1.06
EHD4X48A**	*8MX*1352420**	1.01	1.01	ENH4X43*21**	*9MVX080	1.01	0.99
EHD4X48A**	*8MV*0701412**	1.01	1.03	EN(A,D)4X43*24**	*9MVX100	1.01	0.99
EHD4X48A**	*8MV*0901716**	1.01	1.02	EA*4X48*21A*	*9MX*1002116A**	1.01	1.04
EHD4X48A**	*8MV*1102120**	1.01	1.01	EN(A,D)4X43*24**	*9MX*1002116A**	1.01	1.00
EHD4X48A**	*8MV*1352422**	1.01	1.01	ED*4X42F**	*9MV*1002116A**	1.01	1.07
EHD4X48A**	*9MX*0601714A**	1.01	1.03	EN(A,D,W)4X48*21**	*9MV*1002116A**	1.01	1.02
EHD4X48A**	*9MX*0801716A**	1.01	1.02	EHD4X42A**	*9MA*1002120A**	1.01	1.04
EHD4X48A**	*9MX*0802120A**	1.01	1.01	ED*4X42J**	OLV112A16A	1.01	1.06
EHD4X48A**	*9MX*1002120A**	1.01	1.01	EN(A,D)4X48*24**	OLV112A16A	1.01	1.03
EHD4X48A**	*9MX*1202422A**	1.01	1.00	EN(A,D)4X48*24**	OLV154F20A	1.01	0.99
EHD4X48A**	*9MV*0601714A**	1.01	1.04	ENH4X43*21**	OMV112K14A	1.01	1.01
EHD4X48A**	*9MV*0801716A**	1.01	1.03	ED*4X42J**	-	1.01	1.07
EHD4X48A**	*9MV*0802120A**	1.01	1.02	ED*4X48F**	*9MPV075	1.01	1.04
EHD4X48A**	*9MV*1002120A**	1.01	1.02	ED*4X48L**	*9MPV125	1.01	1.01
EHD4X48A**	*9MV*1202422A**	1.01	1.02	EHD4X42A**	MV20L24**B*	1.01	1.00
EHD4X48A**	*9MA*0601714A**	1.01	1.05	EHD4X48A**	*9MAC0602120A**	1.01	1.04
EHD4X48A**	*9MA*0801714A**	1.01	1.04	EN(A,D,W)4X48*21**	*9MAC0602120A**	1.01	1.04
EN(A,D)4X43*24**	*8MX*1102120**	1.01	0.98	ENH4X42*21**	*9MVX060	1.01	1.08
EN(A,D)4X43*24**	*8MX*1352420**	1.01	0.98	ENH4X48*21**	*9MVX080	1.01	1.01
EN(A,D)4X43*24**	*8MV*1102120**	1.01	0.99	EN(A,D)4X48*24**	*9MX*1002116A**	1.01	1.03
EN(A,D)4X43*24**	*8MV*1352422**	1.01	0.99	ED*4X42J**	*9MV*1002116A**	1.01	1.06
EN(A,D)4X43*24**	*9MX*1202422A**	1.01	0.98	ENH4X42*21**	OLV154F20A	1.01	1.03
EN(A,D)4X43*24**	*9MV*1202422A**	1.01	1.00	EHD4X42A**	*9MAC0602120A**	1.01	1.04
EN(A,D)4X48*24**	*8MX*1352420**	1.01	1.01	ED*4X42L**	*9MVX100	1.01	1.04
EN(A,D)4X48*24**	*8MV*1102120**	1.01	1.01	ED*4X42L**	*9MV*1002116A**	1.01	1.06
EN(A,D)4X48*24**	*9MX*1202422A**	1.01	1.01	ENH4X43*21**	OLV154F20A	1.01	0.97
EN(A,D)4X48*24**	*9MV*1202422A**	1.01	1.02	EHD4X48A**	-	1.01	1.02

HEATING Multiplying Factors for other Indoor Combinations

Indoor Model	Furnace Model	CAPACITY (MBh)	Power (AMPS)	Indoor Model	Furnace Model	CAPACITY (MBh)	Power (AMPS)
EN(A,D,W)4X42*21**	*8MX*0902116**	1.01	1.05	EN(A,D,W)4X48*21**	NOMV156E19*	1.01	1.03
EN(A,D,W)4X42*21**	*8MX*1102120**	1.01	1.05	ED*4X42J**	*9MVX080	1.01	1.04
EN(A,D,W)4X42*21**	*8MV*1102120**	1.01	1.06	EN(A,D,W)4X42*21**	*9MX*1002116A**	1.01	1.07
EN(A,D,W)4X42*21**	*9MX*0601714A**	1.01	1.08	ENH4X42*21**	*9MV*1002116A**	1.01	1.06
EN(A,D,W)4X42*21**	*9MX*0801716A**	1.01	1.07	EHD4X48A**	*9MA*1002120A**	1.01	1.03
EN(A,D,W)4X42*21**	*9MX*0802120A**	1.01	1.05	ED*4X42L**	OLV112A16A	1.01	1.06
EN(A,D,W)4X42*21**	*9MV*1002120A**	1.01	1.06	EN(A,D,W)4X42*21**	OLV112A16A	1.01	1.07
EN(A,D,W)4X42*21**	*9MV*0601714A**	1.01	1.09	ENH4X48*21**	OMV112K14A	1.01	1.03
EN(A,D,W)4X42*21**	*9MV*0801716A**	1.01	1.07	ED*4X42J**	*8MPV100	1.01	1.03
EN(A,D,W)4X42*21**	*9MV*0802120A**	1.01	1.06	ED*4X48F**	MV12F19**B*	1.01	0.99
EN(A,D,W)4X42*21**	*9MV*1002120A**	1.01	1.06	ED*4X48L**	MV20L24**B*	1.01	1.00
EN(A,D,W)4X42*21**	*9MA*0601714A**	1.01	1.09	EMA4X48D**	-	1.01	1.05
EN(A,D,W)4X42*21**	*9MA*0801714A**	1.01	1.08	END4X42*17**	-	1.01	1.05
EN(A,D,W)4X48*21**	*8MX*0902116**	1.01	1.01	ENH4X42*21**	NOMV156E19*	1.01	1.06
EN(A,D,W)4X48*21**	*8MX*1102120**	1.01	1.01	ED*4X48J**	*9MVX080	1.01	1.02
EN(A,D,W)4X48*21**	*8MV*1102120**	1.01	1.02	EN(A,D,W)4X48*21**	*9MX*1002116A**	1.01	1.03
EN(A,D,W)4X48*21**	*9MX*0601714A**	1.01	1.04	ENH4X43*21**	*9MV*1002116A**	1.01	1.02
EN(A,D,W)4X48*21**	*9MX*0801716A**	1.01	1.03	EN(A,D)4X43*24**	*9MA*1002120A**	1.01	1.01
EN(A,D,W)4X48*21**	*9MX*0802120A**	1.01	1.01	ED*4X48F**	OLV112A16A	1.01	1.02
EN(A,D,W)4X48*21**	*9MV*1002120A**	1.01	1.02	EN(A,D,W)4X48*21**	OLV112A16A	1.01	1.03
EN(A,D,W)4X48*21**	*9MV*0601714A**	1.01	1.04	EA*4X42*21A*	*9MAC0602120A**	1.01	1.08
EN(A,D,W)4X48*21**	*9MV*0801716A**	1.01	1.04	ED*4X42J**	*8MPV125	1.01	1.03
EN(A,D,W)4X48*21**	*9MV*0802120A**	1.01	1.02	ED*4X48J**	-	1.01	1.03
EN(A,D,W)4X48*21**	*9MV*1002120A**	1.01	1.02	EHD4X42A**	-	1.01	1.03
EN(A,D,W)4X48*21**	*9MA*0601714A**	1.01	1.06	EN(A,D)4X43*24**	-	1.01	1.01
EN(A,D,W)4X48*21**	*9MA*0801714A**	1.01	1.04	ENH4X42*21**	-	1.01	1.06
END4X42*17**	*8MX*0701716**	1.01	1.06	EN(A,D)4X48*24**	*9MA*1202422A**	1.01	1.03
END4X42*17**	*8MV*0901716**	1.01	1.04	EA*4X48*24A*	*9MX*1002116A**	1.01	1.03
END4X42*17**	*9MX*0601714A**	1.01	1.06	ENH4X48*21**	*9MV*1002116A**	1.01	1.02
END4X42*17**	*9MX*0801716A**	1.01	1.05	EN(A,D)4X48*24**	*9MA*1002120A**	1.01	1.04
END4X42*17**	*9MV*0601714A**	1.01	1.07	EA*4X42*21A*	-	1.01	1.07
END4X42*17**	*9MV*0801716A**	1.01	1.06	ED*4X42J**	*9MPV100	1.01	1.04
END4X42*17**	*9MA*0601714A**	1.01	1.08	EN(A,D)4X43*24**	*9MPV100	1.01	0.98
END4X42*17**	*9MA*0801714A**	1.01	1.07	ENH4X42*21**	*9MPV100	1.01	1.05
ENH4X42*21**	*8MX*0701716**	1.01	1.07	ENH4X42*21**	*9MA*1202422A**	1.01	1.07

HEATING Multiplying Factors for other Indoor Combinations

Indoor Model	Furnace Model	CAPACITY (MBh)	Power (AMPS)	Indoor Model	Furnace Model	CAPACITY (MBh)	Power (AMPS)
ENH4X42*21**	*8MX*0902116**	1.01	1.05	ENH4X43*21**	NOMV156E19*	1.01	1.01
ENH4X42*21**	*8MX*1102120**	1.01	1.05	EHD4X42A**	*9MVX080	1.01	1.01
ENH4X42*21**	*8MX*1352420**	1.01	1.06	ED*4X48L**	*9MVX100	1.01	1.02
ENH4X42*21**	*8MV*0701412**	1.01	1.07	EN(A,D)4X48*24**	*9MVX100	1.01	1.01
ENH4X42*21**	*8MV*0901716**	1.01	1.06	ED*4X42J**	*9MX*1002116A**	1.01	1.07
ENH4X42*21**	*8MV*1102120**	1.01	1.06	ENH4X42*21**	*9MX*1002116A**	1.01	1.07
ENH4X42*21**	*8MV*1352422**	1.01	1.05	ED*4X48F**	*9MV*1002116A**	1.01	1.02
ENH4X42*21**	*9MX*0601714A**	1.01	1.08	EA*4X42*21A*	*9MA*1002120A**	1.01	1.07
ENH4X42*21**	*9MX*0801716A**	1.01	1.07	EN(A,D,W)4X42*21**	*9MA*1002120A**	1.01	1.07
ENH4X42*21**	*9MX*080120A**	1.01	1.05	ED*4X48J**	OLV112A16A	1.01	1.03
ENH4X42*21**	*9MX*1002120A**	1.01	1.06	ENH4X42*21**	OLV112A16A	1.01	1.07
ENH4X42*21**	*9MX*1202422A**	1.01	1.04	ENH4X48*21**	OLV154F20A	1.01	0.99
ENH4X42*21**	*9MV*0601714A**	1.01	1.09	EA*4X42*24A*	-	1.01	1.07
ENH4X42*21**	*9MV*0801716A**	1.01	1.07	ED*4X42J**	MV16J22**B*	1.01	1.03
ENH4X42*21**	*9MV*0802120A**	1.01	1.06	ED*4X48J**	*8MPV100	1.01	1.01
ENH4X42*21**	*9MV*1002120A**	1.01	1.06	EHD4X42A**	*8MPV075	1.01	1.03
ENH4X42*21**	*9MV*1202422A**	1.01	1.06	EHD4X48A**	*8MPV075	1.01	1.02
ENH4X42*21**	*9MA*0601714A**	1.01	1.09	EN(A,D)4X43*24**	*9MPV125	1.01	0.98
ENH4X42*21**	*9MA*0801714A**	1.01	1.08	ENH4X42*21**	*9MAC0602120A**	1.01	1.08
ENH4X43*21**	*9MX*0601714A**	1.01	1.02	EA*4X42*24A*	*9MA*1002120A**	1.01	1.07
ENH4X43*21**	*9MX*0801716A**	1.01	1.01	EN(A,D,W)4X48*21**	*9MA*1002120A**	1.01	1.04
ENH4X43*21**	*9MX*1202422A**	1.01	0.99	ED*4X42F**	OMV112K14A	1.01	1.07
ENH4X43*21**	*9MV*0601714A**	1.01	1.04	EA*4X48*17A*	-	1.01	1.02
ENH4X43*21**	*9MV*0801716A**	1.01	1.03	ED*4X42L**	-	1.01	1.07
ENH4X43*21**	*9MV*1202422A**	1.01	1.01	EHD4X48A**	*8MPV100	1.01	1.00
ENH4X43*21**	*9MA*0601714A**	1.01	1.03	EN(A,D)4X48*24**	-	1.01	1.03
ENH4X43*21**	*9MA*0801714A**	1.01	1.02	ENH4X43*21**	*9MPV100	1.01	0.99
ENH4X48*21**	*8MX*0701716**	1.01	1.04	ENH4X43*21**	*9MA*1202422A**	1.01	1.01
ENH4X48*21**	*8MX*0902116**	1.01	1.01	ENH4X48*21**	NOMV156E19*	1.01	1.03
ENH4X48*21**	*8MX*1102120**	1.01	1.01	EHD4X48A**	*9MVX080	1.01	1.01
ENH4X48*21**	*8MX*1352420**	1.01	1.01	EHD4X42A**	*9MVX100	1.01	1.02
ENH4X48*21**	*8MV*0701412**	1.01	1.04	ENH4X43*21**	*9MVX100	1.01	0.99
ENH4X48*21**	*8MV*0901716**	1.01	1.02	ED*4X42L**	*9MX*1002116A**	1.01	1.06
ENH4X48*21**	*8MV*1102120**	1.01	1.02	ENH4X43*21**	*9MX*1002116A**	1.01	1.01
ENH4X48*21**	*8MV*1352422**	1.01	1.01	ED*4X48J**	*9MV*1002116A**	1.01	1.03

HEATING Multiplying Factors for other Indoor Combinations						
Indoor Model	Furnace Model	CAPACITY (MBh)	Power (AMPS)	Indoor Model	Furnace Model	Power (AMPS)
ENH4X48*21**	*9MX*0601714A**	1.01	1.04	EA*4X48*21A*	*9MA*1002120A**	1.04
ENH4X48*21**	*9MX*0801716A**	1.01	1.03	ENH4X42*21**	*9MA*1002120A**	1.03
ENH4X48*21**	*9MX*0802120A**	1.01	1.01	ED*4X48L**	OLV112A16A	1.01
ENH4X48*21**	*9MX*1002120A**	1.01	1.02	ENH4X43*21**	OLV112A16A	1.01
ENH4X48*21**	*9MX*1202422A**	1.01	1.01	ED*4X48F**	OMV112K14A	1.01
ENH4X48*21**	*9MV*0601714A**	1.01	1.04	EA*4X48*21A*	*9MAC0602120A**	1.04
ENH4X48*21**	*9MV*0801716A**	1.01	1.04	ED*4X42L**	*9MPV125	1.04
ENH4X48*21**	*9MV*0802120A**	1.01	1.02	ED*4X48J**	*8MPV125	1.01
ENH4X48*21**	*9MV*1002120A**	1.01	1.02	EHD4X42A**	*8MPV100	1.01
ENH4X48*21**	*9MV*1202422A**	1.01	1.02	EHD4X48A**	*8MPV125	1.00
ENH4X48*21**	*9MA*0601714A**	1.01	1.06	EN(A,D)4X48*24**	*9MPV100	1.01
ENH4X48*21**	*9MA*0801714A**	1.01	1.04	ENH4X43*21**	*9MPV125	0.99
FEM4P42**A*	-	1.01	1.02	EN(A,D,W)4X42*21**	*9MA*0802120A**	1.02
FEM4P42**A*	-	1.01	1.02	EN(A,D,W)4X48*21**	*9MA*0802120A**	1.03
FEM4P48**A*	-	1.01	1.01	ENH4X42*21**	*9MA*0802120A**	1.01
FEM4P48**A*	-	1.01	1.01	ENH4X48*21**	*9MA*0802120A**	1.03
FEM4X42****	-	1.01	1.02	EA*4X42*21A*	*9MA*1002122A**	1.05
FEM4X48****	-	1.01	0.99	EA*4X48*21A*	*9MA*1002122A**	1.02
FS(M,U)4P42**A*	-	1.01	1.03	EHD4X42A**	*9MA*1002122A**	1.02
FS(M,U)4P42**A*	-	1.01	1.03	EHD4X48A**	*9MA*1002122A**	1.01
FS(M,U)4P48**A*	-	1.01	1.01	EN(A,D,W)4X42*21**	*9MA*1002122A**	1.05
FS(M,U)4P48**A*	-	1.01	1.01	EN(A,D,W)4X48*21**	*9MA*1002122A**	1.02
FS(M,U)4X42****	-	1.01	1.06	ENH4X42*21**	*9MA*1002122A**	1.05
FS(M,U)4X48****	-	1.01	1.04	ENH4X48*21**	*9MA*1002122A**	1.02
FVM4X36****	-	1.01	1.05	EA*4X42*24A*	*9MA*1202422A**	1.05
FVM4X48****	-	1.01	1.00	EA*4X48*24A*	*9MA*1202422A**	1.03
FVM4X60****	-	1.01	0.96	ED*4X42L**	*9MA*1202422A**	1.05
FXM4X48**A*	-	1.01	0.98	ED*4X48J**	*9MA*1202422A**	1.03
-	-	-	-	ENH4X48*21**	*9MAC0602120A**	1.04
HEATING Multiplying Factors for other Indoor Combinations						
Indoor Model	Furnace Model	CAPACITY (MBh)	Power (AMPS)	Indoor Model	Furnace Model	Power (AMPS)
NXH548						
*FXM4X48**A*	-	1.00	1.00	EHD4X48A**	*9MA*1202422A**	1.02
EA*4X48*17A*	*8MV*0901716**	0.98	1.02	EHD4X48A**	*9MX*1002116A**	1.03



HEATING Multiplying Factors for other Indoor Combinations

Indoor Model	Furnace Model	CAPACITY (MBh)	Power (AMPS)	Indoor Model	Furnace Model	CAPACITY (MBh)	Power (AMPS)
EA*4X48*17A*	*9MX*0801716A**	0.99	1.06	EA*4X60*24A*	*9MA*1002120A**	0.98	1.03
EA*4X48*17A*	*9MV*0801716A**	0.99	1.05	ED*4X48F**	-	0.99	1.04
EA*4X48*21A*	*8MX*0902116**	0.98	1.02	ENH4X61*24**	NOMV156E19*	0.98	1.00
EA*4X48*21A*	*8MX*1102120**	0.97	1.00	ENH4X60*24**	*9MVX080	0.99	1.02
EA*4X48*21A*	*8MV*1102120**	0.97	1.02	ENH4X60*24**	*9MX*1002116A**	0.98	1.02
EA*4X48*21A*	*9MX*0801716A**	0.98	1.06	ED*4X48J**	*9MA*1002120A**	0.97	1.03
EA*4X48*21A*	*9MX*0802120A**	0.98	1.03	EN(A,D)4X48*24**	*9MA*1002120A**	0.97	1.03
EA*4X48*21A*	*9MX*1002120A**	0.97	1.02	ENH4X61*24**	*9MA*1002120A**	0.98	1.02
EA*4X48*21A*	*9MV*0801716A**	0.98	1.05	ED*4X48J**	-	1.00	1.05
EA*4X48*21A*	*9MV*0802120A**	0.97	1.02	ED*4X60J**	*8MPV100	0.99	1.01
EA*4X48*21A*	*9MV*1002120A**	0.97	1.02	ED*4X60L**	MV20L24**B*	0.97	0.97
EA*4X48*21A*	*9MA*0802120A**	0.97	1.03	EN(A,D)4X48*24**	*9MPV125	0.98	1.02
EA*4X48*21A*	*9MA*1002122A**	0.97	1.02	EN(A,D,W)4X48*21**	*9MAC0602120A**	0.97	1.04
EA*4X48*24A*	*8MX*1352420**	0.98	1.02	ENH4X60*24**	*9MVX100	0.98	1.01
EA*4X48*24A*	*8MV*1352422**	0.97	1.00	EHD4X48A**	*9MV*1002116A**	0.99	1.04
EA*4X48*24A*	*9MX*1202422A**	0.98	1.02	EHD4X60A**	OLV154F20A	1.00	0.99
EA*4X48*24A*	*9MV*1202422A**	0.98	1.02	EHD4X48A**	MV16J22**B*	0.97	0.98
EA*4X48*24A*	*9MA*1202422A**	0.97	1.02	ENH4X48*21**	*9MPV125	0.98	1.02
EA*4X60*21A*	*8MX*0902116**	0.98	1.00	ED*4X48J**	*9MVX080	0.99	1.04
EA*4X60*21A*	*8MX*1102120**	0.97	0.99	ENH4X61*24**	*9MVX080	1.00	1.01
EA*4X60*21A*	*8MV*1102120**	0.98	1.01	ENH4X61*24**	*9MX*1002116A**	0.99	1.02
EA*4X60*21A*	*9MX*0801716A**	0.99	1.05	ED*4X48J**	*9MA*1002120A**	0.97	1.03
EA*4X60*21A*	*9MX*0802120A**	0.98	1.01	EN(A,D)4X61*24**	*9MA*1002120A**	0.98	1.00
EA*4X60*21A*	*9MX*1002120A**	0.98	1.01	EHD4X60A**	OLV112A16A	0.99	1.03
EA*4X60*21A*	*9MV*0801716A**	0.99	1.04	ED*4X48J**	*8MPV100	0.98	1.02
EA*4X60*21A*	*9MV*0802120A**	0.98	1.01	ED*4X60J**	*8MPV125	0.98	0.99
EA*4X60*21A*	*9MV*1002120A**	0.98	1.01	EHD4X48A**	-	1.00	1.04
EA*4X60*21A*	*9MA*0802120A**	0.97	1.01	EN(A,D)4X61*24**	-	1.01	1.03
EA*4X60*21A*	*9MA*1002122A**	0.97	0.99	EN(A,D,W)4X60*24**	-	1.00	1.04
EA*4X60*24A*	*8MX*1352420**	0.98	1.00	ENH4X61*24**	*9MVX100	0.99	1.00
EA*4X60*24A*	*8MV*1352422**	0.97	0.99	EHD4X60A**	*9MV*1002116A**	0.99	1.02
EA*4X60*24A*	*9MX*1202422A**	0.98	1.00	EN(A,D)4X48*24**	OLV154F20A	1.00	1.03
EA*4X60*24A*	*9MV*1202422A**	0.98	1.01	EHD4X48A**	MV20L24**B*	0.97	0.98
EA*4X60*24A*	*9MA*1202422A**	0.97	1.01	ENH4X48*21**	*9MAC0602120A**	0.97	1.04
ED*4X48F**	*8MV*0901716**	0.98	1.02	EHD4X60A**	*9MX*1002116A**	0.99	1.02

HEATING Multiplying Factors for other Indoor Combinations

Indoor Model	Furnace Model	CAPACITY (MBh)	Power (AMPS)	Indoor Model	Furnace Model	CAPACITY (MBh)	Power (AMPS)
ED*4X48F**	*9MV*0801716A**	0.99	1.05	ED*4X48J**	*8MPV125	0.98	1.01
ED*4X48J**	*8MX*0902116**	0.98	1.02	ED*4X60J**	*9MVX080	0.99	1.02
ED*4X48J**	*8MX*1102120**	0.97	1.00	ED*4X48L**	*9MVX100	0.98	1.02
ED*4X48J**	*8MV*1102120**	0.97	1.02	EA*4X48*21A*	*9MV*1002116A**	0.98	1.04
ED*4X48J**	*9MX*1202422A**	0.98	1.03	EN(A,D)4X61*24**	OLV154F20A	1.01	1.00
ED*4X48J**	*9MV*1202422A**	0.97	1.02	EHD4X48A**	*9MAC0602120A**	0.97	1.03
ED*4X48J**	*9MA*1202422A**	0.97	1.03	ENH4X60*24**	-	1.00	1.04
ED*4X48L**	*8MX*1352420**	0.98	1.02	EA*4X48*21A*	*9MX*1002116A**	0.98	1.04
ED*4X48L**	*8MV*1352422**	0.97	1.00	EN(A,D)4X48*24**	*9MV*1002116A**	0.98	1.03
ED*4X48L**	*9MX*1202422A**	0.98	1.02	EN(A,D,W)4X60*24**	OLV154F20A	1.00	1.01
ED*4X48L**	*9MV*1202422A**	0.98	1.02	EHD4X60A**	-	1.00	1.03
ED*4X48L**	*9MA*1202422A**	0.97	1.02	ENH4X60*24**	*9MPV100	0.99	1.02
ED*4X60J**	*8MX*0902116**	0.98	1.00	EHD4X48A**	*9MVX080	0.99	1.03
ED*4X60J**	*8MX*1102120**	0.97	0.99	ED*4X60L**	*9MVX100	0.98	1.01
ED*4X60J**	*8MV*1102120**	0.98	1.01	EA*4X48*24A*	*9MV*1002116A**	0.98	1.04
ED*4X60J**	*9MV*1202422A**	0.98	1.01	EHD4X60A**	*8MPV100	0.99	0.99
ED*4X60J**	*9MA*1202422A**	0.97	1.01	ENH4X60*24**	*9MPV125	0.99	1.02
ED*4X60L**	*8MX*1352420**	0.98	1.00	EA*4X48*24A*	*9MX*1002116A**	0.98	1.04
ED*4X60L**	*8MV*1352422**	0.97	0.99	EN(A,D)4X61*24**	*9MV*1002116A**	0.98	1.00
ED*4X60L**	*9MX*1202422A**	0.98	1.00	ENH4X48*21**	OLV154F20A	1.00	1.03
ED*4X60L**	*9MV*1202422A**	0.98	1.00	ENH4X60*24**	OLV154F20A	1.00	1.01
ED*4X60L**	*9MA*1202422A**	0.97	1.01	EHD4X60A**	*8MPV125	0.98	0.98
ED*4X60L**	*8MX*1352420**	0.98	1.01	ENH4X61*24**	-	1.01	1.02
ED*4X60L**	*8MV*1352422**	0.97	0.99	ENH4X61*24**	*9MPV100	1.00	1.02
ED*4X60L**	*9MX*1202422A**	0.98	1.00	ENH4X60A**	*9MVX080	0.99	1.00
ED*4X60L**	*9MV*1202422A**	0.97	1.01	EHD4X48A**	*9MVX100	0.98	1.02
ED*4X60L**	*9MA*1202422A**	0.97	1.01	EA*4X60*21A*	*9MX*1002116A**	0.98	1.03
EHD4X48A**	*8MX*0902116**	0.98	1.01	EN(A,D)4X48*24**	*9MX*1002116A**	0.98	1.04
EHD4X48A**	*8MX*1102120**	0.97	1.00	EA*4X60*21A*	*9MV*1002116A**	0.99	1.03
EHD4X48A**	*8MV*1102120**	0.98	1.02	EN(A,D,W)4X48*21**	*9MV*1002116A**	0.98	1.03
EHD4X48A**	*8MV*1352422**	0.97	1.00	ED*4X48L**	*9MA*1002120A**	0.97	1.03
EHD4X48A**	*9MX*0801716A**	0.98	1.06	EN(A,D,W)4X48*21**	*9MA*1002120A**	0.97	1.03
EHD4X48A**	*9MV*1002120A**	0.98	1.02	EN(A,D)4X61*24**	OLV112A16A	1.00	1.03
EHD4X48A**	*9MX*0802120A**	0.98	1.02	ENH4X61*24**	OLV154F20A	1.01	1.00
EHD4X48A**	*9MX*1002120A**	0.98	1.02	ED*4X48J**	*9MPV100	0.99	1.04

HEATING Multiplying Factors for other Indoor Combinations

Indoor Model	Furnace Model	CAPACITY (MBh)	Power (AMPS)	Indoor Model	Furnace Model	CAPACITY (MBh)	Power (AMPS)
EHD4X48A**	*9MV*0802120A**	0.98	1.02	ED*4X60J**	*9MPV100	0.99	1.02
EHD4X48A**	*9MV*1002120A**	0.97	1.00	EHD4X48A**	*8MPV100	0.98	1.00
EHD4X48A**	*9MV*1202422A**	0.98	1.02	EHD4X60A**	*9MPV100	0.99	1.01
EHD4X48A**	*9MA*0802120A**	0.97	1.02	EN(A,D)4X61*24**	*9MPV100	1.00	1.01
EHD4X48A**	*9MA*1002122A**	0.98	1.01	EN(A,D,W)4X60*24**	*9MPV100	0.99	1.02
EHD4X60A**	*8MX*0902116**	0.98	0.99	EN(A,D)4X48*24**	*9MVX080	0.99	1.03
EHD4X60A**	*8MX*1102120**	0.98	0.98	EHD4X60A**	*9MVX100	0.98	1.00
EHD4X60A**	*8MX*1352420**	0.98	0.99	EA*4X60*24A*	*9MX*1002116A**	0.98	1.02
EHD4X60A**	*8MV*0901716**	0.98	1.00	EN(A,D)4X61*24**	*9MX*1002116A**	0.99	1.01
EHD4X60A**	*8MV*1102120**	0.98	1.00	EA*4X60*24A*	*9MV*1002116A**	0.99	1.03
EHD4X60A**	*8MV*1352422**	0.97	0.98	EN(A,D,W)4X60*24**	*9MV*1002116A**	0.99	1.03
EHD4X60A**	*9MX*0801716A**	0.99	1.04	ED*4X60J**	*9MA*1002120A**	0.98	1.03
EHD4X60A**	*9MX*0802120A**	0.98	0.99	EN(A,D,W)4X60*24**	*9MA*1002120A**	0.97	1.02
EHD4X60A**	*9MX*1002120A**	0.98	0.99	ED*4X48L**	OLV154F20A	1.00	1.03
EHD4X60A**	*9MX*1202422A**	0.98	0.99	EA*4X48*17A*	-	0.99	1.04
EHD4X60A**	*9MV*0801716A**	0.99	1.03	ED*4X48J**	MV16J22**B*	0.97	0.99
EHD4X60A**	*9MV*0802120A**	0.98	1.00	ED*4X60J**	MV16J22**B*	0.97	0.97
EHD4X60A**	*9MV*1002120A**	0.98	0.99	EHD4X48A**	*8MPV125	0.98	1.00
EHD4X60A**	*9MV*1202422A**	0.98	0.99	EHD4X60A**	*9MPV125	0.99	1.00
EHD4X60A**	*9MA*0802120A**	0.97	1.00	EN(A,D)4X61*24**	*9MPV125	0.99	0.99
EHD4X60A**	*9MA*1002122A**	0.98	1.00	EN(A,D,W)4X60*24**	*9MPV125	0.99	1.02
EN(A,D)4X48*24**	*8MX*1352420**	0.97	1.00	ED*4X48J**	*9MX*1002116A**	0.98	1.04
EN(A,D)4X48*24**	*8MV*1352422**	0.97	1.00	ENH4X48*21**	*9MV*1002116A**	0.98	1.03
EN(A,D)4X48*24**	*9MX*1202422A**	0.98	1.02	EA*4X48*21A*	*9MAC0602120A**	0.97	1.04
EN(A,D)4X48*24**	*9MV*1202422A**	0.97	1.01	EHD4X60A**	MV16J22**B*	0.97	0.96
EN(A,D)4X61*24**	*8MX*1352420**	0.98	0.97	ED*4X48J**	*9MX*1002116A**	0.98	1.04
EN(A,D)4X61*24**	*8MV*1102120**	0.98	0.99	ED*4X48F**	*9MV*1002116A**	0.99	1.04
EN(A,D)4X61*24**	*8MV*1352422**	0.98	0.98	ENH4X60*24**	*9MV*1002116A**	0.99	1.03
EN(A,D)4X61*24**	*9MX*1202422A**	0.99	0.99	EA*4X48*21A*	-	1.00	1.05
EN(A,D)4X61*24**	*9MV*1202422A**	0.97	0.98	EHD4X60A**	MV20L24**B*	0.97	0.96
EN(A,D,W)4X48*21**	*8MX*0902116**	0.98	1.02	EN(A,D)4X61*24**	*9MVX080	1.00	1.01
EN(A,D,W)4X48*21**	*8MX*1102120**	0.97	1.00	EN(A,D)4X48*24**	*9MVX100	0.98	1.02
EN(A,D,W)4X48*21**	*8MV*1102120**	0.97	1.01	ED*4X48J**	*9MV*1002116A**	0.98	1.04
EN(A,D,W)4X48*21**	*9MX*0801716A**	0.98	1.05	ED*4X60L**	*9MA*1002120A**	0.98	1.03
EN(A,D,W)4X48*21**	*9MX*0802120A**	0.98	1.02	ENH4X48*21**	*9MA*1002120A**	0.97	1.03

HEATING Multiplying Factors for other Indoor Combinations

Indoor Model	Furnace Model	CAPACITY (MBh)	Power (AMPS)	Indoor Model	Furnace Model	CAPACITY (MBh)	Power (AMPS)
EN(A,D,W)4X48*21**	*9MX*1002120A**	0.97	1.00	ED*4X60L**	OLV154F20A	1.00	1.00
EN(A,D,W)4X48*21**	*9MV*0801716A**	0.98	1.04	ED*4X48L**	-	1.00	1.05
EN(A,D,W)4X48*21**	*9MV*0802120A**	0.97	1.01	ED*4X60L**	-	1.00	1.03
EN(A,D,W)4X48*21**	*9MV*1002120A**	0.97	1.01	EHD4X48A**	*9MPV100	0.99	1.03
EN(A,D,W)4X48*21**	*9MA*0802120A**	0.97	1.02	EN(A,D,W)4X48*21**	-	1.00	1.05
EN(A,D,W)4X48*21**	*9MA*1002122A**	0.97	1.01	ENH4X48*21**	-	1.00	1.05
EN(A,D,W)4X60*24**	*8MX*1352420**	0.98	1.00	ED*4X48L**	*9MX*1002116A**	0.98	1.04
EN(A,D,W)4X60*24**	*8MV*1352422**	0.97	0.99	ENH4X61*24**	*9MV*1002116A**	0.98	1.02
EN(A,D,W)4X60*24**	*9MX*1202422A**	0.98	1.00	EA*4X48*24A*	-	1.00	1.05
EN(A,D,W)4X60*24**	*9MV*1202422A**	0.98	1.00	EHD4X60A**	*9MAC0602120A**	0.97	1.02
ENH4X48*21**	*8MX*0902116**	0.98	1.02	EN(A,D,W)4X48*21**	*9MVX080	0.99	1.03
ENH4X48*21**	*8MX*1102120**	0.97	1.00	EN(A,D)4X61*24**	*9MVX100	0.99	0.99
ENH4X48*21**	*8MX*1352420**	0.97	1.00	ED*4X60J**	*9MX*1002116A**	0.98	1.03
ENH4X48*21**	*8MV*0901716**	0.97	1.02	EN(A,D,W)4X48*21**	*9MX*1002116A**	0.98	1.04
ENH4X48*21**	*8MV*1102120**	0.97	1.01	ED*4X48L**	*9MV*1002116A**	0.98	1.04
ENH4X48*21**	*8MV*1352422**	0.97	1.00	EA*4X48*21A*	*9MA*1002120A**	0.97	1.03
ENH4X48*21**	*9MX*0801716A**	0.98	1.05	ED*4X60L**	*9MA*1002120A**	0.98	1.03
ENH4X48*21**	*9MX*0802120A**	0.98	1.02	ENH4X60*24**	*9MA*1002120A**	0.97	1.02
ENH4X48*21**	*9MX*1002120A**	0.97	1.00	EHD4X48A**	OLV154F20A	1.00	1.02
ENH4X48*21**	*9MX*1202422A**	0.98	1.02	EA*4X60*21A*	*9MAC0602120A**	0.97	1.03
ENH4X48*21**	*9MV*0801716A**	0.98	1.04	ED*4X48L**	*9MPV125	0.98	1.02
ENH4X48*21**	*9MV*0802120A**	0.97	1.01	ED*4X60L**	*9MPV125	0.99	1.02
ENH4X48*21**	*9MV*1002120A**	0.97	1.01	EHD4X48A**	*9MPV125	0.98	1.02
ENH4X48*21**	*9MV*1202422A**	0.97	1.01	EMA4X48D**	-	0.98	1.06
ENH4X48*21**	*9MA*0802120A**	0.97	1.02	EN(A,D,W)4X48*21**	*9MPV100	0.99	1.03
ENH4X48*21**	*9MA*1002122A**	0.97	1.01	ENH4X48*21**	*9MPV100	0.99	1.03
ENH4X60*24**	*8MX*0902116**	0.98	1.00	EN(A,D,W)4X60*24**	*9MVX080	0.99	1.02
ENH4X60*24**	*8MX*1102120**	0.97	0.98	EN(A,D,W)4X60*24**	*9MVX100	0.98	1.01
ENH4X60*24**	*8MX*1352420**	0.98	1.00	ED*4X60L**	*9MX*1002116A**	0.98	1.02
ENH4X60*24**	*8MV*0901716**	0.97	1.00	EN(A,D,W)4X60*24**	*9MX*1002116A**	0.98	1.02
ENH4X60*24**	*8MV*1102120**	0.97	1.00	ED*4X60J**	*9MV*1002116A**	0.99	1.03
ENH4X60*24**	*8MV*1352422**	0.97	0.99	EA*4X48*24A*	*9MA*1002120A**	0.97	1.03
ENH4X60*24**	*9MX*0801716A**	0.99	1.04	EHD4X48A**	*9MA*1002120A**	0.98	1.03
ENH4X60*24**	*9MX*1202422A**	0.98	1.00	EA*4X60*21A*	-	1.00	1.03
ENH4X60*24**	*9MV*0801716A**	0.99	1.04	ED*4X48L**	MV20L24**B*	0.97	0.98

HEATING Multiplying Factors for other Indoor Combinations

Indoor Model	Furnace Model	CAPACITY (MBh)	Power (AMPS)	Indoor Model	Furnace Model	CAPACITY (MBh)	Power (AMPS)
ENH4X60*24**	*9MV*1202422A**	0.98	1.00	EN(A,D)4X48*24**	-	1.00	1.05
ENH4X61*24**	*8MX*0902116**	0.99	1.00	ENH4X48*21**	*9MVX080	0.99	1.03
ENH4X61*24**	*8MX*1102120**	0.98	0.98	ENH4X48*21**	*9MVX100	0.98	1.02
ENH4X61*24**	*8MX*1352420**	0.98	0.99	ED*4X60L**	*9MX*1002116A**	0.98	1.02
ENH4X61*24**	*8MV*0901716**	0.98	1.00	ENH4X48*21**	*9MX*1002116A**	0.98	1.04
ENH4X61*24**	*8MV*1102120**	0.98	1.00	ED*4X60L**	*9MV*1002116A**	0.99	1.03
ENH4X61*24**	*8MV*1352422**	0.98	0.99	EA*4X60*21A*	*9MA*1002120A**	0.98	1.03
ENH4X61*24**	*9MX*0801716A**	0.99	1.03	EHD4X60A**	*9MA*1002120A**	0.98	1.02
ENH4X61*24**	*9MX*1202422A**	0.99	1.00	EA*4X60*24A*	-	1.00	1.03
ENH4X61*24**	*9MV*0801716A**	0.98	1.03	ED*4X60J**	-	1.00	1.03
ENH4X61*24**	*9MV*1202422A**	0.97	1.00	EN(A,D)4X48*24**	*9MPV100	0.99	1.03
FEM4P48**A*	-	0.99	1.03	EHD4X60A**	*9MA*1202422A**	0.97	1.00
FEM4P48**A*	-	0.98	1.02	EN(A,D)4X48*24**	*9MA*1202422A**	0.97	1.02
FEM4P60**A*	-	0.99	1.00	EN(A,D)4X61*24**	*9MA*1202422A**	0.97	0.98
FEM4P60**A*	-	0.99	1.00	EN(A,D,W)4X60*24**	*9MA*1202422A**	0.97	1.01
FEM4X48****	-	0.99	1.00	ENH4X48*21**	*9MA*1202422A**	0.97	1.02
FEM4X60****	-	1.00	0.98	ENH4X60*24**	*9MA*1202422A**	0.97	1.01
FS(M,U)4P48**A*	-	0.99	1.02	ENH4X61*24**	*9MA*1202422A**	0.97	1.00
FS(M,U)4P48**A*	-	0.99	1.02	ED*4X48J**	NOMV156E19*	0.98	1.04
FS(M,U)4X48****	-	1.00	1.06	ED*4X60J**	NOMV156E19*	0.98	1.02
FS(M,U)4X60****	-	1.01	1.04	EHD4X48A**	NOMV156E19*	0.98	1.02
FS(M,U)4X60**A*	-	1.01	1.04	EHD4X60A**	NOMV156E19*	0.98	1.00
FVM4X48****	-	0.97	0.99	EN(A,D,W)4X48*21**	NOMV156E19*	0.97	1.02
FVM4X60****	-	0.97	0.96	ENH4X48*21**	NOMV156E19*	0.97	1.02
FXM4X60**A*	-	0.99	0.96	ENH4X60*24**	NOMV156E19*	0.98	1.02
-	-	-	-	ENH4X61*24**	*9MPV125	0.99	1.00

HEATING Multiplying Factors for other Indoor Combinations

Indoor Model	Furnace Model	CAPACITY (MBh)	Power (AMPS)	Indoor Model	Furnace Model	CAPACITY (MBh)	Power (AMPS)
<b>NXH560</b>							
*FXM4X60**A*	-	1.00	1.00	ED*4X60L**	*9MX*1202422A**	1.00	1.05
EA*4X60*21A*	*8MX*1102120**	1.00	1.04	EHD4X60A**	*9MV*1002120A**	1.01	1.05
EA*4X60*21A*	*8MV*1102120**	1.01	1.06	ED*4X60L**	*9MA*1002120A**	1.01	1.08
EA*4X60*21A*	*9MX*0802120A**	1.00	1.06	ENH4X60*24**	-	0.99	1.05
EA*4X60*24A*	*8MX*1352420**	1.00	1.05	EHD4X60A**	*9MA*0802120A**	1.00	1.05

HEATING Multiplying Factors for other Indoor Combinations

Indoor Model	Furnace Model	CAPACITY (MBh)	Power (AMPS)	Indoor Model	Furnace Model	CAPACITY (MBh)	Power (AMPS)
EA*4X60*24A*	*8MV*1352422**	1.00	1.04	ED*4X60J**	*8MPV125	1.01	1.05
EA*4X60*24A*	*9MX*1202422A**	1.00	1.05	-	-	-	-
ED*4X60J**	*8MX*1102120**	0.99	1.03	EA*4X60*24A*	*9MV*1202422A**	1.01	1.06
ED*4X60J**	*8MX*1102120**	0.99	1.03	ED*4X60J**	*9MV*1202422A**	1.01	1.06
ED*4X60J**	*8MV*1102120**	0.99	1.05	EHD4X60A**	*9MA*1002120A**	1.01	1.07
ED*4X60J**	*8MV*1102120**	0.99	1.05	EN(A,D)4X61*24**	*9MA*1002120A**	1.01	1.06
ED*4X60L**	*8MX*1352420**	0.99	1.04	EA*4X60*21A*	*9MA*1002122A**	1.00	1.05
ED*4X60L**	*8MX*1352420**	0.99	1.04	EHD4X60A**	*9MA*1002122A**	1.00	1.03
ED*4X60L**	*8MV*1352422**	0.99	1.03	ED*4X60J**	MV16J22**B*	1.00	1.02
ED*4X60L**	*8MV*1352422**	0.99	1.03	ED*4X60L**	-	1.01	1.06
EHD4X60A**	*8MX*1102120**	0.99	1.02	ED*4X60L**	*9MV*1202422A**	1.01	1.06
EHD4X60A**	*8MX*1102120**	0.99	1.02	EHD4X60A**	*9MV*1202422A**	1.01	1.05
EHD4X60A**	*8MX*1352420**	0.99	1.02	EA*4X60*24A*	*9MA*1202422A**	1.00	1.05
EHD4X60A**	*8MX*1352420**	0.99	1.02	ED*4X60L**	*9MA*1202422A**	1.00	1.05
EHD4X60A**	*8MV*1102120**	0.99	1.03	EN(A,D,W)4X60*24**	*9MA*1002120A**	1.00	1.08
EHD4X60A**	*8MV*1102120**	0.99	1.03	ENH4X60*24**	*9MA*1002120A**	1.00	1.08
EHD4X60A**	*8MV*1352422**	0.99	1.02	ED*4X60L**	MV20L24**B*	1.00	1.02
EHD4X60A**	*8MV*1352422**	0.99	1.02	EHD4X60A**	-	1.01	1.05
EHD4X60A**	*9MX*0802120A**	1.00	1.04	ENH4X61*24**	-	0.99	1.03
EHD4X60A**	*9MX*1002120A**	1.01	1.05	ENH4X61*24**	-	0.99	1.03
EN(A,D)4X61*24**	*8MX*1352420**	0.99	1.01	ED*4X60L**	*9MA*1202422A**	1.00	1.05
EN(A,D)4X61*24**	*8MX*1352420**	0.99	1.01	EHD4X60A**	*9MA*1202422A**	1.00	1.04
EN(A,D)4X61*24**	*8MV*1352422**	0.99	1.01	EHD4X60A**	*8MPV125	1.01	1.04
EN(A,D)4X61*24**	*8MV*1352422**	0.99	1.01	EHD4X60A**	MV16J22**B*	1.00	1.01
EN(A,D,W)4X60*24**	*8MX*1352420**	0.99	1.04	EN(A,D)4X61*24**	*9MA*1202422A**	1.00	1.03
EN(A,D,W)4X60*24**	*8MX*1352420**	0.99	1.04	EN(A,D,W)4X60*24**	*9MA*1202422A**	1.00	1.05
EN(A,D,W)4X60*24**	*8MV*1352422**	0.99	1.03	EHD4X60A**	MV20L24**B*	1.00	1.00
EN(A,D,W)4X60*24**	*8MV*1352422**	0.99	1.03	EN(A,D)4X61*24**	-	0.99	1.02
ENH4X60*24**	*8MX*1102120**	0.99	1.03	EN(A,D)4X61*24**	*9MV*1202422A**	1.00	1.03
ENH4X60*24**	*8MX*1102120**	0.99	1.03	EN(A,D,W)4X60*24**	*9MV*1202422A**	1.01	1.06
ENH4X60*24**	*8MX*1352420**	0.99	1.04	ENH4X60*24**	*9MA*1202422A**	1.00	1.05
ENH4X60*24**	*8MX*1352420**	0.99	1.04	ENH4X61*24**	*9MA*1202422A**	1.00	1.04
ENH4X60*24**	*8MV*1102120**	0.99	1.05	ENH4X61*24**	*9MA*1002120A**	1.01	1.08
ENH4X60*24**	*8MV*1102120**	0.99	1.05	EA*4X60*21A*	-	1.01	1.06
ENH4X60*24**	*8MV*1352422**	0.99	1.03	EN(A,D)4X61*24**	-	0.99	1.02

HEATING Multiplying Factors for other Indoor Combinations

Indoor Model	Furnace Model	CAPACITY (MBh)	Power (AMPS)	Indoor Model	Furnace Model	CAPACITY (MBh)	Power (AMPS)
ENH4X60*24**	*8MV*1352422**	0.99	1.03	EN(A,D,W)4X60*24**	-	0.99	1.05
ENH4X61*24**	*8MX*1102120**	0.99	1.02	ENH4X60*24**	*9MV*1202422A**	1.01	1.06
ENH4X61*24**	*8MX*1102120**	0.99	1.02	ENH4X61*24**	*9MV*1202422A**	1.00	1.04
ENH4X61*24**	*8MX*1352420**	0.99	1.03	EA*4X60*21A*	*9MA*1002120A**	1.01	1.09
ENH4X61*24**	*8MX*1352420**	0.99	1.03	EA*4X60*24A*	*9MA*1002120A**	1.01	1.08
ENH4X61*24**	*8MV*1102120**	0.99	1.03	EA*4X60*24A*	-	1.01	1.06
ENH4X61*24**	*8MV*1102120**	0.99	1.03	ED*4X60J**	-	1.01	1.06
ENH4X61*24**	*8MV*1352422**	0.99	1.02	EN(A,D,W)4X60*24**	-	0.99	1.05
ENH4X61*24**	*8MV*1352422**	0.99	1.02	ENH4X60*24**	-	0.99	1.05
FEM4P60**A*	-	1.00	1.05	ED*4X60L**	*9MX*1202422A**	1.00	1.05
FEM4P60**A*	-	1.00	1.05	EHD4X60A**	*9MX*1202422A**	1.00	1.04
FEM4X60****	-	1.00	1.01	EN(A,D)4X61*24**	*9MX*1202422A**	1.01	1.04
FS(M,U)4X60****	-	1.02	1.07	EN(A,D,W)4X60*24**	*9MX*1202422A**	1.00	1.05
FS(M,U)4X60**A*	-	1.02	1.07	ENH4X60*24**	*9MX*1202422A**	1.00	1.05
FVM4X60****	-	1.00	1.00	ENH4X61*24**	*9MX*1202422A**	1.00	1.04