

AEPF183016AA
AEPF183016BA
AEPF183016CA
AEPF303616AA
AEPF303616BA
AEPF303616BB
AEPF303616CA
AEPF313716AA
AEPF426016AA
AEPF426016BA
AEPF426016BB
AEPF426016CA

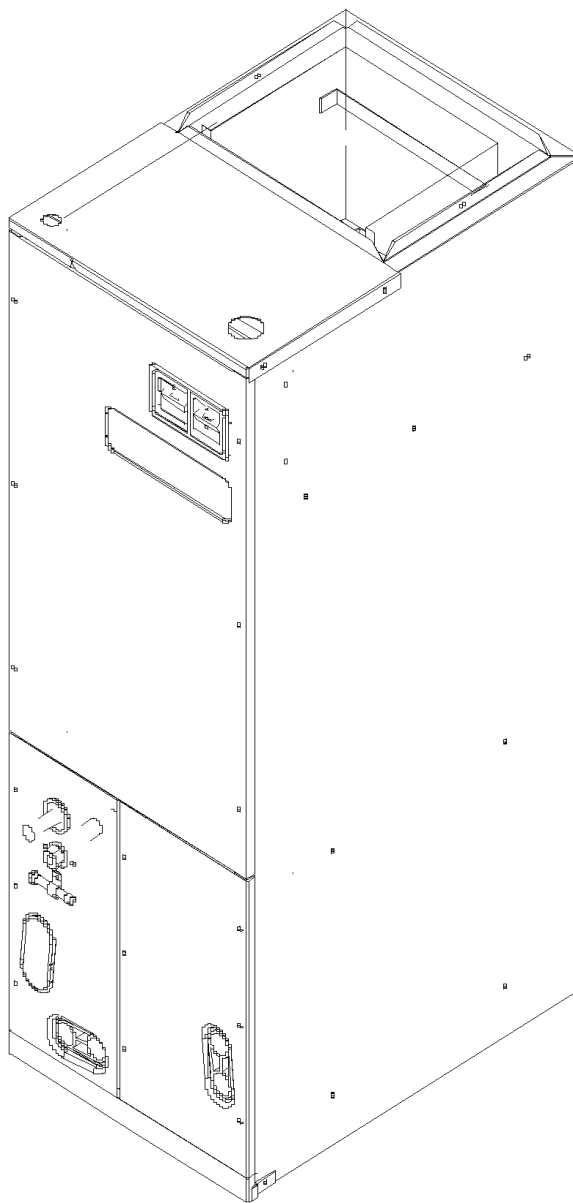

This manual is to be used by qualified technicians only.

This manual replaces RP-382E.

© 2006-2009 Goodman Manufacturing Company, L.P. ♦ 5151 San Felipe, Suite 500 ♦ Houston, TX 77056

Important Information

Index

Functional Parts List	3
Illustration and Parts	4 - 5

Views shown are for parts illustrations only, not servicing procedures.

Rev. F: Added model AEPF313716AA.

February 2013: Removed 1202404 Coil Assy and replaced with 0202A00006 Coil Assy

Text Codes:

AR - As Required

NA - Not Available

NS - Not Shown

00000000 - See Note

QTY - Quantity Example (QTY 3) (If Quantity not shown, Quantity = 1)

M - Model Example (M1) (If M Code not shown, then part is used on all Models)

Expanded Model Nomenclature:

Example M1 - Model#1 M2 - Model#2 M3 - Model#3

Goodman Manufacturing Company, L.P. is not responsible for personal injury or property damage resulting from improper service. Review all service information before beginning repairs.

Warranty service must be performed by an authorized technician, using authorized factory parts. If service is required after the warranty expires, Goodman Manufacturing Company, L.P. also recommends contacting an authorized technician and using authorized factory parts.

Goodman Manufacturing Company, L.P. reserves the right to discontinue, or change at any time, specifications or designs without notice or without incurring obligations.

For assistance within the U.S.A. contact:
Consumer Affairs Department
Goodman Manufacturing Company, L.P.
7401 Security Way
Houston, Texas 77040
877-254-4729-Telephone
713-863-2382-Facsimile

For assistance outside the U.S.A. contact:
International Division
Goodman Manufacturing Company, L.P.
7401 Security Way
Houston, Texas 77040
713-861-2500-Telephone
713-863-2382-Facsimile

Functional Parts

Part

No: Description:

PCBEM102S	ECM PRIMARY BOARD
B13400702ABS	MOTOR, VARIABLE SPEED 1/2 HP (M1, M2, M3)
B13400704ABS	MOTOR, VARIABLE SPEED 3/4 HP (M4, M5, M6, M7, M8, M9, M10, M11, M12)
B1141643	TRANSFORMER 208/230, 24V

SPECIAL PARTS

IO-287D	INSTALLATION INSTRUCTIONS
PKC-0AC	PISTON KIT CHART
RP-382F	REPAIR PARTS MANUAL

Expanded Model Nomenclature

M1 - AEPF183016AA
M2 - AEPF183016BA
M3 - AEPF183016CA
M4 - AEPF303616AA
M5 - AEPF303616BA
M6 - AEPF303616BB
M7 - AEPF303616CA
M8 - AEPF313716AA
M9 - AEPF426016AA
M10 - AEPF426016BA
M11 - AEPF426016BB
M12 - AEPF426016CA

Unit Assembly

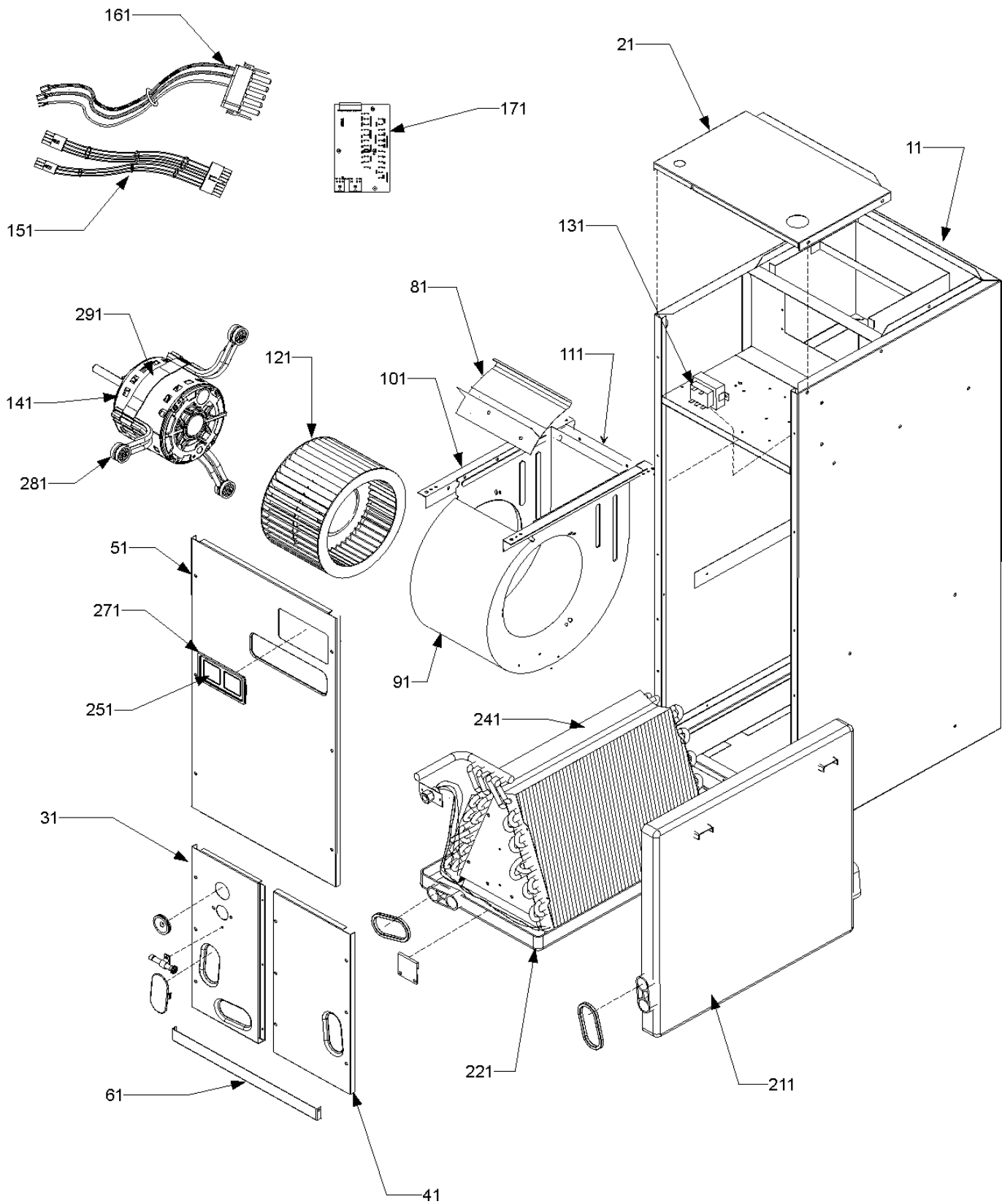

Unit Assembly

Ref. Part No:	No:	Description:	Ref. Part No:	No:	Description:
<i>Image 1:</i>			<i>Image 1:</i>		
11	1721122PDG	WRAPPER (M1, M2, M3)	251	B1392641	PLASTIC CIRCUIT BREAKER INSERT
11	1721123PDG	WRAPPER (M4, M5, M6, M7, M8, M9, M10, M11, M12)	271	B13926122	CIRCUIT BREAKER INSERT GASKET
21	0121A00033PDG	UPPER TIE PLATE (M1, M2, M3)	281	B1376853	MOTOR MOUNT ARM (M4, M5, M6, M7, M8, M9, M10, M11, M12)
21	0121A00035PDG	UPPER TIE PLATE (M4, M5, M6, M7, M8, M9, M10, M11, M12)	281	B1376861	MOTOR MOUNT ARM (M1, M2, M3)
31	1722077PDG	LOWER ACCESS PANEL (M1, M2, M3)	291	0121M00038	MOTOR MOUNT BAND
31	1722078PDG	LOWER ACCESS PANEL (M4, M5, M6, M7, M8, M9, M10, M11, M12)	NS	1721918	BOTTOM TIE LRG (M4, M5, M6, M7, M8, M9, M10, M11, M12)
41	1722080PDG	LOWER SERVICE PANEL (M1, M2, M3)	NS	1721917	BOTTOM TIE MED (M1, M2, M3)
41	1722081PDG	LOWER SERVICE PANEL (M4, M5, M6, M7, M8, M9, M10, M11, M12)	NS	0162D00005P	FLOWRATOR .065 (M1, M2, M3)
51	1722083PDG	UPPER ACCESS PANEL (M1, M2, M3)	NS	0162D00032S	FLOWRATOR .074 (M4, M5, M6, M7, M8)
51	1722084PDG	UPPER ACCESS PANEL (M4, M5, M6, M7, M8, M9, M10, M11, M12)	NS	0162D00007P	FLOWRATOR .093 (M9, M10, M11, M12)
61	1722087PDG	FILTER COVER LRG (M4, M5, M6, M7, M8, M9, M10, M11, M12)	NS	B1796630	INLET TUBE FLOWRATOR
61	1722086PDG	FILTER COVER MED (M1, M2, M3)	NS	B1378701	WIRE HARNESS, HIGH VOLTAGE (5-PIN ECM)
81	764741F	BLOWER BLOCK-OFF 10 X 10 (M6, M7, M8, M11, M12)	NS	B1378700	WIRE HARNESS, LOW VOLTAGE (16-PIN ECM)
81	764734F	BLOWER CUT-OFF (M1, M2, M3)	Expanded Model Nomenclature		
81	1824004	BLOWER CUT-OFF 11 & 10 X 10 (M4, M5, M9, M10)	M1 - AEPF183016AA M2 - AEPF183016BA M3 - AEPF183016CA M4 - AEPF303616AA M5 - AEPF303616BA M6 - AEPF303616BB M7 - AEPF303616CA M8 - AEPF313716AA M9 - AEPF426016AA M10 - AEPF426016BA M11 - AEPF426016BB M12 - AEPF426016CA		
91	1439397S	BLOWER HOUSING (M4, M5, M9, M10)			
91	0271A00016S	BLOWER HOUSING ASSY 10 X 10 (M6, M7, M8, M11, M12)			
91	1439392S	BLOWER HOUSING ASSY 9 X 8 (M1, M2, M3)			
101	0121A00027	BLOWER MOUNTING ANGLE (M1, M2, M3, M4, M5, M9, M10)			
111	1717109	BLOWER MOUNTING ANGLE (M1, M2, M3, M4, M5, M9, M10)			
121	B1368048S	BLOWER WHEEL 10 X 10 (M4, M5, M6, M7, M8, M9, M10, M11, M12)			
121	B1368037S	BLOWER WHEEL 9 X 8 (M1, M2, M3)			
131	B1141643	TRANSFORMER 208/230, 24V			
141	B13400702ABS	MOTOR, VARIABLE SPEED 1/2 HP (M1, M2, M3)			
141	B13400704ABS	MOTOR, VARIABLE SPEED 3/4 HP (M4, M5, M6, M7, M8, M9, M10, M11, M12)			
151	0259A00002P	WIRE ASSY, 9-PIN MALE CONNECTOR			
161	0259A00004P	WIRE ASSY, 9-PIN FEMALE CONNECTOR			
171	PCBEM102S	ECM PRIMARY BOARD			
211	B1756022L	PLASTIC DRAIN PAN (HORIZONTAL) (M1, M2, M3)			
211	B1756028L	PLASTIC DRAIN PAN (HORIZONTAL) (M4, M5, M6, M7, M8, M9, M10, M11, M12)			
221	B1756017L	PLASTIC DRAIN PAN (VERTICAL) (M1, M2, M3)			
221	B1756020L	PLASTIC DRAIN PAN (VERTICAL) (M4, M5, M6, M7, M8, M9, M10, M11, M12)			
241	0202A00006	COIL PAN ASSY (M4, M5, M6, M7)			
241	0270A00413S	COIL PAN ASSY (M8)			
241	1262403	COIL PAN ASSY (M1, M2, M3)			
241	1262405	COIL PAN ASSY (M9, M10, M11, M12)			