

FIG. 1

NOTES:

Bearing to be installed with seal towards commutator.

4,31 Press needle bearing flush $\pm .005$ with inner surface of diaphragm.

6,49 Apply Blue Loctite® 242 to treads of wobble shaft axle prior to installing spinlock hex nut. Torque spinlock hex nut to 160-190 in. lbs.

6,40 Hold the intermediate gear still with a large pair of pliers and a piece of rubber hose (or other tough, but pliable material to protect the gear from the jaws of the pliers) and remove the 5/16" spinlock hex nut with a wrench, as shown.

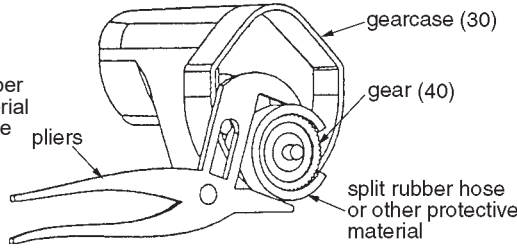

Service Fixture 61-10-0270 (Pressing Pin Tool)

7,46,50,51,56 Press dowel pins flush to front side of front spindle bushing. Press dowel pins flush to back side of rear spindle bushing. **NOTE:** Reciprocating spindle (46) and counter weight (56) must be installed inside assembly (7,50) and (7,51) prior to pressing last spindle bushing into place. Be sure to orientate the counter weight with the hole on bottom towards rear spindle bushing, as shown.

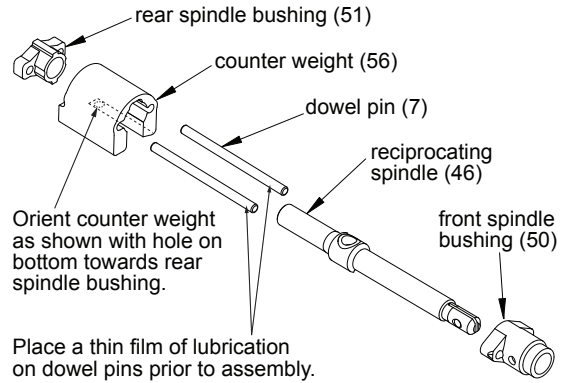

17,37 Install nameplate in motor housing recess prior to assembling diaphragm onto motor housing.

29,42 **Service fixture #61-10-0205** must be used when installing retaining ring (42) onto orbit pocket assembly (29).

40,57 Tabs of bronze plate engage intermediate gear.

40,48 Concave side of disc spring towards intermediate gear.

58,61 Tabs of metal plates engage orbit drive hub.

70 O-ring of polypak seal faces mechanism - toward rear of tool.

74 Shoulder extension of grease slinger should face bearing.

REMOVING THE STEEL QUIK-LOK® BLADE CLAMP

- Remove external retaining ring (44) and pull front cam (53) off.
- Pull lock pin (65) out and remove remainder of parts and discard.

REASSEMBLY OF THE STEEL QUIK-LOK® BLADE CLAMP

- Coat new lock pin with powdered graphite.
- Hold tool in a vertical position.
- Place spring cover (34) onto spindle.
- Slide torsion spring (47) onto spindle shaft with leg positioned at the 6:00 position.
- Slide sleeve (73) onto spindle aligning hole on sleeve with hole in spindle.
- Slide rear cam (54) over sleeve, aligning hole in rear cam with spring leg. Ensure spring leg inserts into hole in rear cam.
- Rotate rear cam (54) counter clockwise until there is clearance for lock pin (65) to be inserted into sleeve/spindle holes. Insert lock pin.
- Align front cam (53) inner ribs with rear cam outer slots (*see insert*) and slide front cam onto sleeve until it bottoms. Retaining ring (44) groove should be completely visible.
- Attach retaining ring by separating coils and inserting end of ring into groove, then wind remainder of ring into groove. Ensure ring is seated in groove.
- Blade clamp should rotate freely. During normal usage, debris may not allow blade clamp to rotate freely. The use of spray lubricant can help free blade clamp. In extreme conditions, follow these instructions to remove, clean and reassemble blade clamp.

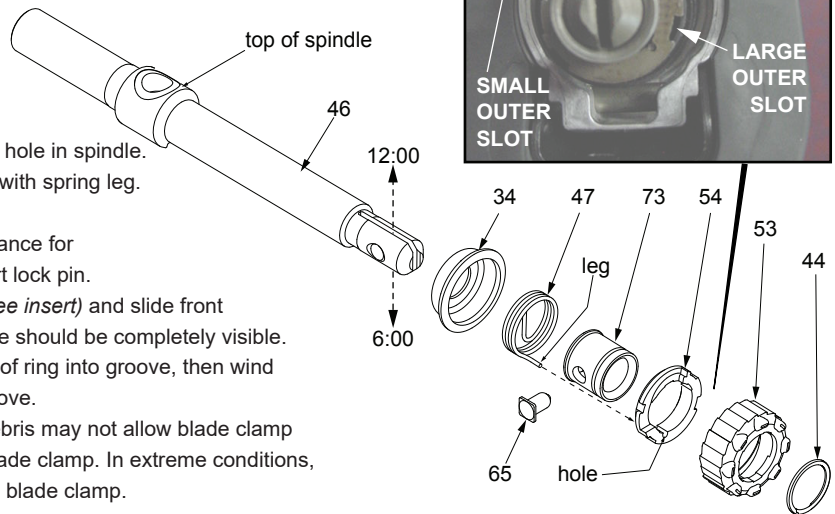

FIG. LUBRICATION:

29,41 Lightly coat o-rings with lubrication for ease of installation onto assembled orbit pockets.

30 Place 3.2 oz. (80 grams \pm 8 grams) of type "T" grease (Cat. No. 49-08-4290), in mechanism cavity of gear case.

31 Place .8 oz. (20 grams \pm 2 grams) of type "T" grease (Cat. No. 49-08-4290), in lower needle bearing-gear train cavity of diaphragm.

40,58 Apply a thin coat of type "T" grease (Cat. No. 49-08-4290) between gear and metal plate.

65 Pin to be coated with graphite prior to assembly.

87 Soak in lightweight bushing oil prior to assembly.

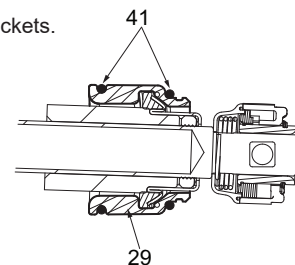

WIRING INSTRUCTIONS

TITLE **6538-21 SAWZALL® with 14-20-1115 Remote Electronics Assembly**

BULLETIN

MILWAUKEE ELECTRIC TOOL CORP. 13135 WEST LISBON RD. BROOKFIELD, WIS.

DATE

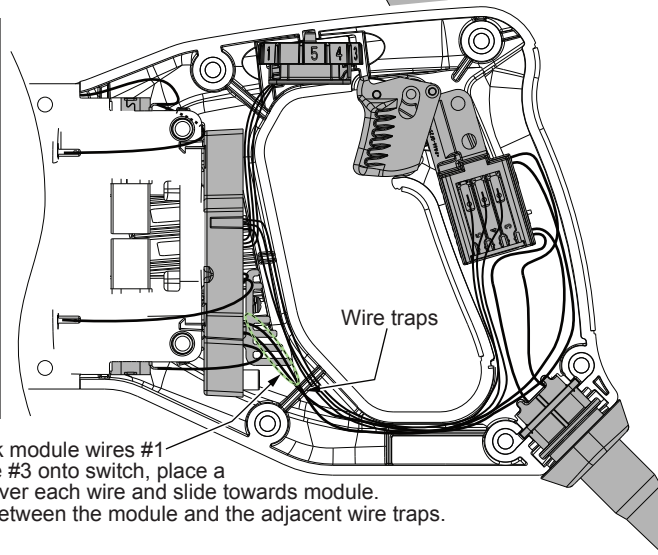
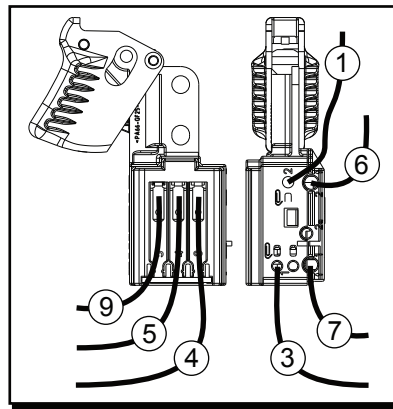
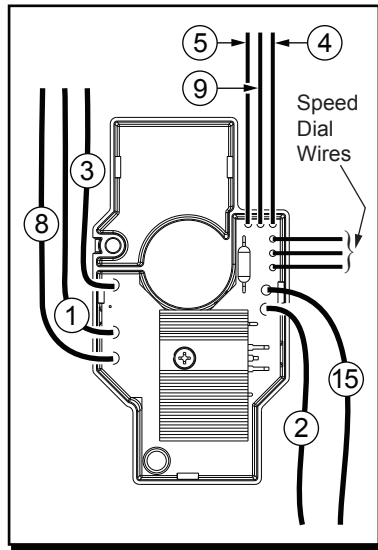
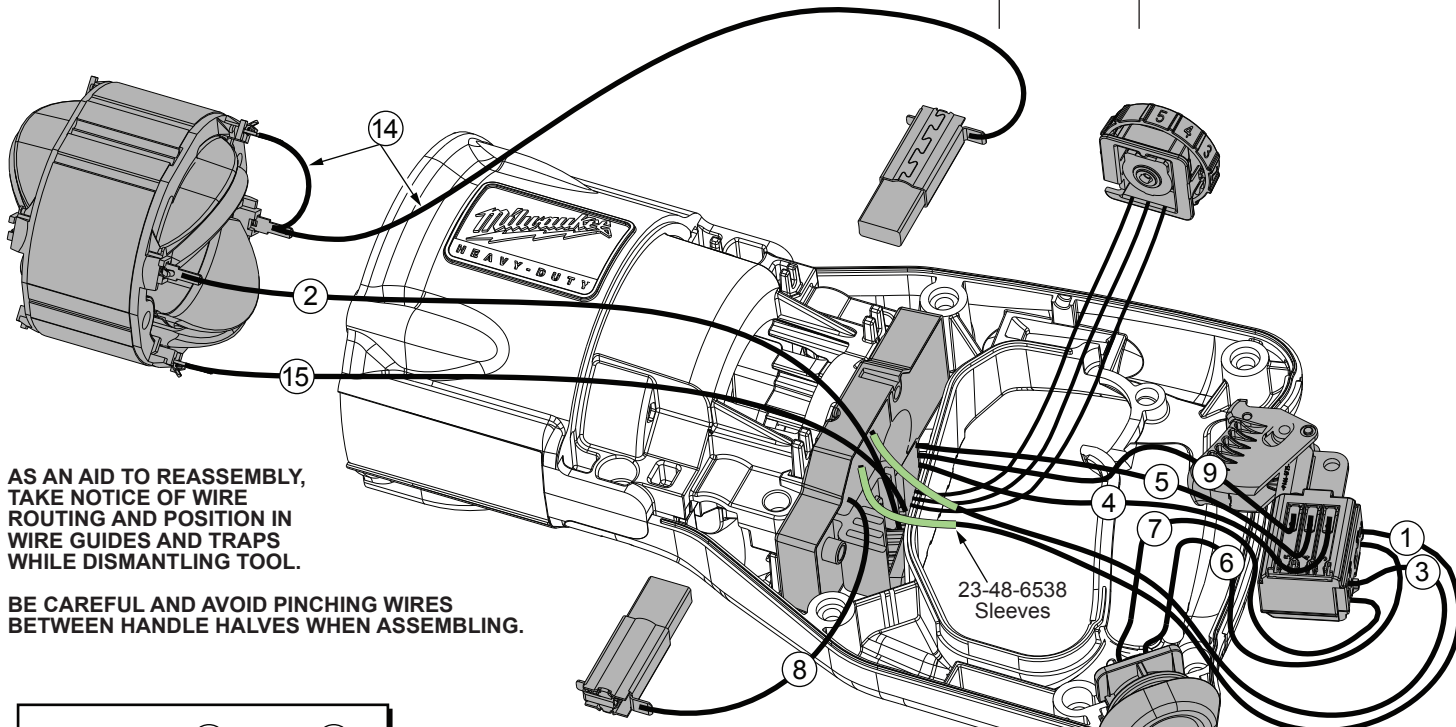

Prior to installing black module wires #1 and white module wire #3 onto switch, place a sleeve (23-48-6538) over each wire and slide towards module. Locate both sleeves between the module and the adjacent wire traps.

WIRING SPECIFICATIONS

Wire No.	Wire Color	Origin or Gauge	Length	Terminals, Connectors and 1 or 2 End Wire Preparation
1	Black	14-20-1105	----	Component of the speed control module. Connect to position '2' on the back of the on-off switch.
2	Yellow	14-20-1105	----	Component of the speed control module. Connect to the bottom left field terminal.
3	White	14-20-1105	----	Component of the speed control module. Connect to position '1' on the back of the on-off switch.
4	Black	14-20-1105	----	Component of the speed control module. Connect to position '3' on the left side of the on-off switch.
5	White	14-20-1105	----	Component of the speed control module. Connect to position '4' on the left side of the on-off switch.
6	Black	22-64-4522	----	Component of the power cord set. Connect the other end to position '2↑' on switch.
7	White	22-64-4522	----	Component of the power cord set. Connect the other end to position '1↑' on switch.
8	Black	14-20-1105	----	Component of the speed control module. Connect to the bottom brush tube terminal.
9	Blue	14-20-1105	----	Component of the speed control module. Connect to position '5' on the left side of the on-off switch.
14	White	23-94-7425	----	Leadwire assembly. Connect to the top right and left field terminals. Connect to top brush tube terminal.
15	Yellow	14-20-1105	----	Component of the speed control module. Connect to the bottom right field terminal.