

Seismic Bracing

Fig. 1001 - Sway Brace Attachment



Component of State of California OSHPD Approved Seismic Restraints System

Size Range: Pipe size to be braced: 1" (25mm) thru 8" (200mm) IPS.
 * Pipe size used for bracing: 1" (25mm) and 1 1/4" (32mm) Schedule 40 IPS.

Material: Steel

Function: For bracing pipe against sway and seismic disturbance. The pipe attachment component of a sway brace system: Fig. 1001 is used in conjunction with a Fig. 900 Series fitting and joined together with bracing pipe per NFPA 13, forming a complete sway brace assembly.

Features: Can be used to brace schedules 7 through 40 IPS. Field adjustable, making critical pre-engineering of bracing pipe length unnecessary. Unique design requires no threading of bracing pipe. Can be used as a component of a four-way riser brace. Comes assembled and ready for installation. Fig. 1001 has built-in visual verification of correct installation. See installation note below.

Installation Note: Position Fig. 1001 over the pipe to be braced and tighten two hex head cone point set screws until heads bottom out. A minimum of 1" (25mm) pipe extension is recommended. Brace pipe can be installed on top or bottom of pipe to be braced.

Approvals: Underwriters Laboratories Listed in the USA (UL) and Canada (cUL). Approved by Factory Mutual Engineering (FM). Included in our Seismic Restraints Catalog approved by the State of California Office of Statewide Health Planning and Development (OSHPD). For additional load, spacing and placement information relating to OSHPD projects, please refer to the TOLCO Seismic Restraint Systems Guidelines, OPA-0300-10.

Finish: Plain or Electro-Galvanized. Contact B-Line for alternative finishes and materials.

Order By: Indicate pipe size to be braced followed by pipe size used for bracing, figure number and finish.

Important Note: Fig. 1001 is precision manufactured to perform its function as a critical component of a complete bracing assembly. To ensure performance, the UL Listing requires that Fig. 1001 must be used only with other TOLCO bracing products.

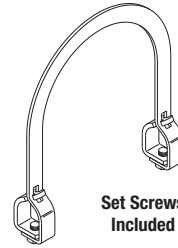

Set Screws Included



Pipe Size in. (mm)	UL Listed Design Load - Lbs. For Brace Pipe Size 1" / 1 1/4"		
	Sch. 7 1" / 1 1/4"	Sch. 10 1" / 1 1/4"	Sch. 40 1" / 1 1/4"
1" (25)	-- / --	1000 / 1000	1000 / 1000
1 1/4" (32)	1000 / 1000	1000 / 1000	1000 / 1000
1 1/2" (40)	1000 / 1000	1500 / 1500	1500 / 1500
2" (50)	1000 / 1000	2015 / 2015	2015 / 2015
2 1/2" (65)	1600 / 1600	2015 / 2765	2015 / 2765
3" (80)	1600 / 1600	2015 / 2765	2015 / 2765
4" (100)	1600 / 1600	2015 / 2765	2015 / 2765
6" (150)	1600 / 1600	2015 / 2765	2015 / 2765
8" (200)	1600 / 1600	2015 / 2765	2015 / 2765

Pipe Size in. (mm)	Part Number & Approx. Wt./100				FM Design Load - For Sch. 7, Sch. 10, & Sch. 40 Pipe Allowable Horizontal Capacity (lb) Per Installation ^{1,2,3}									
	1" (24mm) Brace Pipe		1 1/4" (32mm) Brace Pipe		30°-44°		45°-59°		60°-74°		75°-90°			
	Lbs.	(kg)	Lbs.	(kg)	Lbs.	(kN)	Lbs.	(kN)	Lbs.	(kN)	Lbs.	(kN)		
1" (25)	1001-1 X 1	100.0	(45.3)	1001-1 X 1 1/4	118.0	(53.5)	1800	(8.00)	2550	(11.34)	3120	(13.88)	3490	(25.52)
1 1/4" (32)	1001-1 1/4 X 1	100.0	(45.3)	1001-1 1/4 X 1 1/4	114.0	(51.7)	1230	(5.47)	1740	(7.74)	2140	(9.52)	2380	(10.58)
1 1/2" (40)	1001-1 1/2 X 1	100.0	(45.3)	1001-1 1/2 X 1 1/4	115.0	(52.1)	1230	(5.47)	1740	(7.74)	2140	(9.52)	2380	(10.58)
2" (50)	1001-2 X 1	108.0	(49.0)	1001-2 X 1 1/4	121.0	(54.9)	1230	(5.47)	1740	(7.74)	2140	(9.52)	2380	(10.58)
2 1/2" (65)	1001-2 1/2 X 1	138.6	(62.8)	1001-2 1/2 X 1 1/4	160.4	(72.7)	800	(3.56)	1130	(5.02)	1380	(6.14)	1540	(6.85)
3" (80)	1001-3 X 1	147.2	(66.7)	1001-3 X 1 1/4	168.7	(76.5)	850	(3.78)	1200	(5.34)	1470	(6.54)	1640	(7.29)
4" (100)	1001-4 X 1	160.9	(73.0)	1001-4 X 1 1/4	182.4	(82.7)	850	(3.78)	1200	(5.34)	1470	(6.54)	1640	(7.29)
6" (150)	1001-6 X 1	190.0	(86.2)	1001-6 X 1 1/4	211.4	(95.9)	510	(2.27)	730	(3.25)	890	(3.96)	990	(4.40)
8" (200)	1001-8 X 1	217.4	(98.6)	1001-8 X 1 1/4	238.8	(108.3)	510	(2.27)	730	(3.25)	890	(3.96)	990	(4.40)

¹ FM Approved when used with 1 or 1 1/4 inch NPS Schedule 40 GB/T 3091, EN 10255H, or JIS G3451 steel pipe as the brace member.

² Load rating for LW above refers to FM Approved Lightwall Pipe commonly referred to as "Schedule 7". These ratings may also be applied when EN 10220 and GB/T 8163 steel pipe.

³ Load rating for Schedule 10 above may be applied to GB/T 3092, EN 10255M and H, or JIS G3454, FM Approved Thinwall, or Schedule 40 steel pipes.

Note: See UL load ratings in UL Listed Design Load chart shown under drawing.



Fig. 2002 - Sway Brace Attachment

Size Range: Pipe size to be braced: 2½" (65mm) thru 8" (200mm) all steel schedules, copper, plastic, FRP, cast iron and ductile iron. Consult factory when bracing other than steel. The Fig. 2002 accepts brace pipes sizes 1½" (40mm) and 2" (50mm) steel schedule 100 through schedule 40.

Material: Steel

Function: For bracing pipe against sway and seismic disturbance. The pipe attachment component of a sway brace system: Fig. 2002 is used in conjunction with a TOLCO 900 Series sway brace attachments and joined together with bracing pipe. Install per NFPA 13 and/or TOLCO State of California OSHPD Approved Seismic Restrain Manual.

Features: Unique design will not damage thin wall, plastic, copper or ductile iron pipe. Easy verification of proper installation by tightening bolts until ears touch.

Installation: Place Fig. 2002 over pipe to be braced. Slide bracing pipe through attachment and tighten hex nuts until ears touch.

Approvals: Underwriters Laboratories Listed in the USA (UL) and Canada (cUL). Included in our Seismic Restraints Catalog approved by the State of California Office of Statewide Health Planning and Development (OSHPD). For additional load, spacing and placement information relating to OSHPD projects, please refer to the TOLCO Seismic Restraint Systems Guidelines.

Finish: Plain. Contact B-Line for alternative finishes and materials.

Order By: Figure number, pipe size to be braced, pipe size used for bracing (1½" (40mm) or 2" (50mm)) and finish.

Important Note: Fig. 2002 is precision manufactured to perform its function as a critical component of a complete bracing assembly. To ensure performance, the UL Listing requires that the Fig. 2002 must be used only with other TOLCO bracing products.



Component of State of California OSHPD Approved Seismic Restraints System

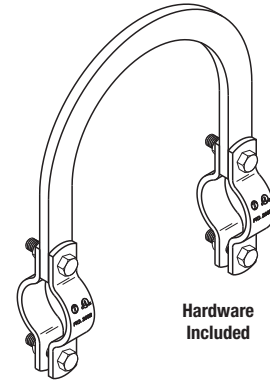

Hardware Included

UL Listed Design Load
2015 lbs. (8.96kN)

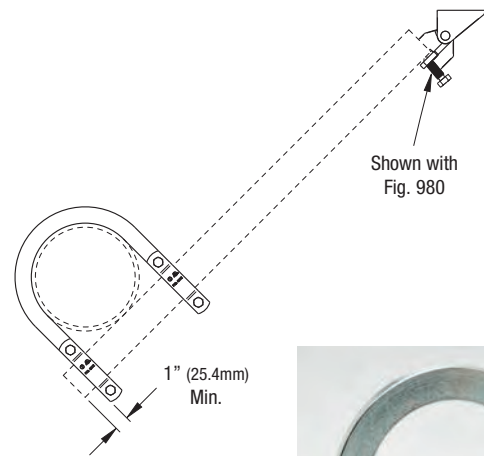

Pipe Size in. (mm)	Part Number & Approx. Wt./100				Design Load **		
	1½" (32mm) Brace Pipe		2" (50mm) Brace Pipe				
	Part Number	Lbs.	(kg)	Part Number	Lbs.	(kg)	
2½" (65)	2002-2½ X 1½	224.9	(102.0)	2002-2½ X 2	283.3	(128.6)	UL
3" (80)	2002-3 X 1½	241.0	(109.3)	2002-3 X 2	299.4	(135.8)	UL
4" (100)	2002-4 X 1½	268.4	(121.7)	2002-4 X 2	326.8	(148.2)	UL
6" (150)	2002-6 X 1½	326.6	(148.1)	2002-6 X 2	385.0	(174.6)	UL
8" (200)	2002-8 X 1½	381.3	(172.9)	2002-8 X 2	439.7	(199.4)	UL

** See load ratings in UL Listed Design Load chart.

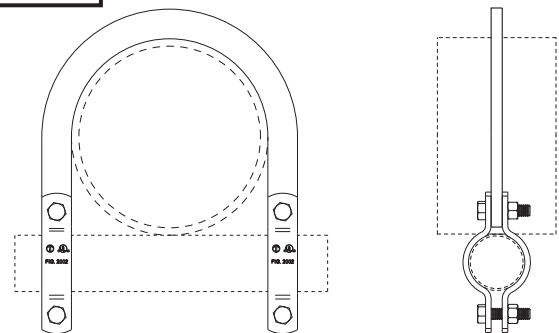

Seismic Bracing

All dimensions in charts and on drawings are in inches. Dimensions shown in parentheses are in millimeters unless otherwise specified.