

INSTALLATION

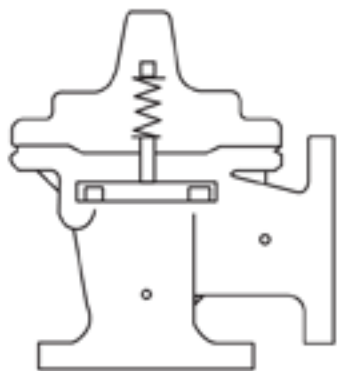

OPERATION

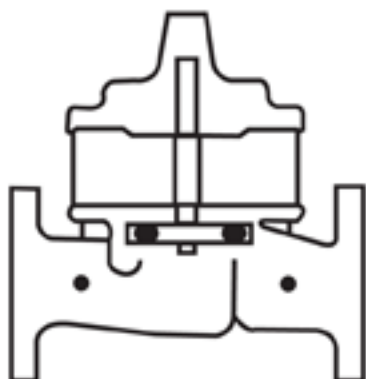

MAINTENANCE



NEWPORT BEACH, CALIFORNIA

CATALOG NO.
60-32/660-32

DRAWING NO.
91333

REV
J

TYPE OF VALVE AND MAIN FEATURES

COMBINATION PUMP CONTROL AND BACK PRESSURE VALVE

DESIGN

DRAWN NAL 11-29-88

CHK'D CH 3-6-89

APVD CH 3-6-89

H REDRAWN ON CAD; ADDED CRL60 TO COMPONENT LIST; ADDED CAT# 660-32 (ECO 23596)
J REMOVED (4" AND LARGER ONLY) FROM DESCRIPTION (ECO 24251)

CAD REVISION RECORD - DO NOT REVISE MANUALLY
DESCRIPTION BY DATE
A-F SEE REVISION FILE
G ADDED ITEM B3 AND REDRAWN ON CAD (ECO 9910) NAL 11-29-88

----- NOT FURNISHED BY CLA-VAL CO. ----- OPTIONAL FEATURES

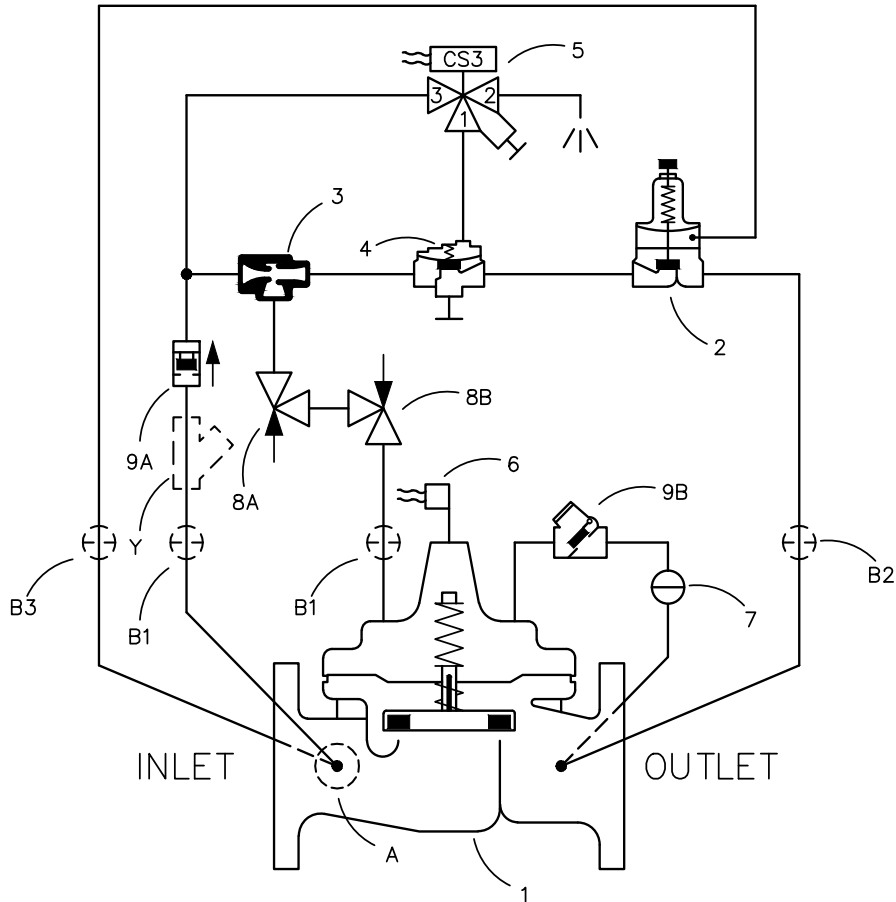

ITEM NO.	BASIC COMPONENTS	QTY			
1	100-04 HY-CHECK (60-32) MAIN VALVE	1	8	CV FLOW CONTROL	2
	100-23 HY-CHECK (660-32) MAIN VALVE		9	CDC/CSC CHECK VALVE	2
2	CRL/CRL60 PRESSURE RELIEF CONTROL	1			
3	X47A EJECTOR	1			
4	100-01 AUXILIARY HYTROL (REV. FLOW)	1			
5	CS3SM SOLENOID CONTROL	1			
6	X105LCW LIMIT SWITCH ASSEMBLY	1			
7	CK2 COCK (ISOLATION VALVE)	1			

OPTIONAL FEATURE SUFFIX		ADDED TO CATALOG NUMBER	
A	X46A FLOW CLEAN STRAINER	1	
B	CK2 COCK (ISOLATION VALVE)	4	
Y	X43 "Y" STRAINER	1	

"THIS DRAWING IS THE PROPERTY OF CLA-VAL CO. AND SAME AND COPIES MADE THEREOF, IF ANY, SHALL BE RETURNED TO IT UPON DEMAND. DELIVERY AND DISCLOSURE HEREOF ARE SOLELY UPON CONDITION THAT THE SAME SHALL NOT BE USED, COPIED OR REPRODUCED, NOR SHALL THE SUBJECT HEREOF BE DISCLOSED IN ANY MANNER TO ANYONE FOR ANY PURPOSE, EXCEPT AS HEREIN AUTHORIZED, WITHOUT PRIOR WRITTEN APPROVAL OF CLA-VAL CO. THIS DRAWING IS SUBMITTED CONFIDENTIALLY AND MAY NOT BE USED IN THE MANUFACTURE OF ANY MATERIAL OR PRODUCT OTHER THAN SUCH MATERIALS AND PRODUCTS FURNISHED TO CLA-VAL CO. WHETHER OR NOT THE EQUIPMENT OR INFORMATION SHOWN HEREON IS PATENTED OR OTHERWISE PROTECTED, FULL TITLE AND COPYRIGHTS, IF ANY, IN AND TO THIS DRAWING AND/OR INFORMATION DELIVERED OR SUBMITTED ARE FULLY RESERVED BY CLA-VAL CO."

CLA-VAL CO.

NEWPORT BEACH, CALIFORNIA

CATALOG NO.

60-32/660-32

DRAWING NO.

91333

REV

J

TYPE OF VALVE AND MAIN FEATURES

COMBINATION PUMP CONTROL AND BACK PRESSURE VALVE

DESIGN

DRAWN NAL

11-29-88

CHK'D CH

3-6-89

APVD CH

3-6-89

OPERATING DATA

I. SOLENOID CONTROL FEATURE:

SOLENOID CONTROL (5) IS A DIRECT-ACTING, 3-WAY SOLENOID CONTROL THAT CHANGES POSITION WHEN THE COIL IS DE-ENERGIZED OR ENERGIZED. THIS APPLIES OR RELIEVES PRESSURE IN THE COVER CHAMBER OF AUXILIARY HYTROL (4), PROVIDING THE OPERATION SHOWN IN THE FOLLOWING TABLE:

SOLENOID CONTROL (5)		AUXILIARY HYTROL (4) POSITION	MAIN VALVE (1) POSITION
POSITION	PORTS CONNECTED		
ENERGIZED	1 & 2	OPEN	OPEN UNDER COMMAND OF CONTROL (2)
DE-ENERGIZED	1 & 3	CLOSED	CLOSED

NOTE: SOLENOID CONTROL (5) IS EQUIPPED WITH A MANUAL ACTUATOR WHICH CAN BE USED TO OPERATE THE SOLENOID WITHOUT ELECTRICAL POWER. AFTER MANUAL ACTUATION, ALWAYS RETURN THE ACTUATOR TO ITS ORIGINAL POSITION OR THE SOLENOID WILL NOT RETURN TO THE DE-ENERGIZED POSITION.

II. BACK PRESSURE CONTROL FEATURE:

PRESSURE RELIEF CONTROL (2) IS A NORMALLY CLOSED CONTROL THAT RESPONDS TO MAIN VALVE INLET PRESSURE CHANGES. AN INCREASE IN INLET PRESSURE TENDS TO OPEN CONTROL (2) AND A DECREASE IN INLET PRESSURE TENDS TO CLOSE CONTROL (2). THIS CAUSES MAIN VALVE COVER PRESSURE TO VARY AND THE MAIN VALVE MODULATES (OPENS AND CLOSES), MAINTAINING A RELATIVELY CONSTANT INLET PRESSURE. WHEN INLET PRESSURE IS LOWER THAN THE SET POINT OF CONTROL (2), CONTROL (2) CLOSES. THIS PRESSURIZES THE COVER OF THE MAIN VALVE AND THE MAIN VALVE CLOSES, MAINTAINING THE DESIRED BACK PRESSURE. PRESSURE RELIEF CONTROL (2) ADJUSTMENT: TURN THE ADJUSTING SCREW CLOCKWISE TO INCREASE THE SETTING.

III. CHECK VALVE FEATURE:

THE MAIN VALVE (1) HAS AN INTEGRAL CHECK FEATURE. WHEN OUTLET PRESSURE IS HIGHER THAN INLET PRESSURE, THE MAIN VALVE (1) CLOSES PREVENTING REVERSE FLOW, CHECK VALVE (9B) OPENS, AND CHECK VALVE (9A) CLOSES. THIS DIRECTS THE HIGHER OUTLET PRESSURE INTO THE MAIN VALVE COVER CHAMBER AND THE DIAPHRAGM ASSEMBLY MOVES TO THE DOWN POSITION.

CAD REVISION RECORD - DO NOT REVISE MANUALLY

DATE

BY

DESCRIPTION

SEE SHEET 1

LTR



NEWPORT BEACH, CALIFORNIA

CATALOG NO.
60-32/660-32

DRAWING NO.
91333

REV
J

TYPE OF VALVE AND MAIN FEATURES

COMBINATION PUMP CONTROL AND BACK PRESSURE VALVE

DESIGN		
DRAWN	NAL	11-29-88
CHK'D	CH	3-6-89
APVD	CH	3-6-89

OPERATING DATA-CONTINUED

IV. SWITCH ASSEMBLY FEATURE:

SWITCH ASSEMBLY (6) IS ACTUATED BY A STEM EXTENSION ATTACHED TO THE MAIN VALVE STEM. THE SWITCH ASSEMBLY IS FACTORY ADJUSTED TO ACTUATE A SINGLE-POLE DOUBLE-THROW SWITCH WHEN THE MAIN VALVE IS ALMOST CLOSED. WHEN THE MAIN VALVE STARTS TO OPEN, THE SPRING-LOADED SWITCH-ACTUATING LEVER IS RELEASED AND RETURNS THE SWITCH TO ITS NORMAL POSITION.

V. OPENING SPEED CONTROL:

FLOW CONTROL (8A) CONTROLS THE OPENING SPEED OF THE MAIN VALVE. TURN THE ADJUSTING STEM CLOCKWISE TO MAKE THE MAIN VALVE OPEN SLOWER.

VI. CLOSING SPEED CONTROL:

FLOW CONTROL (8B) CONTROLS THE CLOSING SPEED OF THE MAIN VALVE. TURN THE ADJUSTING STEM CLOCKWISE TO MAKE THE MAIN VALVE CLOSE SLOWER.

VII. OPTIONAL FEATURE OPERATING DATA:

SUFFIX A (FLOW CLEAN STRAINER):

A SELF-CLEANING STRAINER IS INSTALLED IN THE MAIN VALVE INLET BODY BOSS WHICH PROTECTS THE PILOT SYSTEM FROM FOREIGN PARTICLES.

SUFFIX B (ISOLATION VALVES):

CK2 COCKS (B1), (B2), AND (B3) ARE USED TO ISOLATE THE PILOT SYSTEM FROM MAIN LINE PRESSURE. THESE VALVES MUST BE OPEN DURING NORMAL OPERATION.

SUFFIX Y (Y-STRAINER):

A Y-PATTERN STRAINER IS INSTALLED IN THE PILOT SUPPLY LINE TO PROTECT THE PILOT SYSTEM FROM FOREIGN PARTICLES. THE STRAINER SCREEN MUST BE CLEANED PERIODICALLY.

CAD REVISION RECORD - DO NOT REVISE MANUALLY	DATE	
	BY	
DESCRIPTION	SEE SHEET 1	
LTR		

 CLA-VAL CO. NEWPORT BEACH, CALIFORNIA	CATALOG NO. 60-32/660-32	DRAWING NO. 91333	REV J
	TYPE OF VALVE AND MAIN FEATURES COMBINATION PUMP CONTROL AND BACK PRESSURE VALVE		DESIGN DRAWN NAL 11-29-88 CHK'D CH 3-6-89 APVD CH 3-6-89

OPERATING DATA-CONTINUED

VIII. CHECK LIST FOR PROPER OPERATION:

- () SYSTEM VALVES OPEN UPSTREAM AND DOWNSTREAM.
- () AIR REMOVED FROM THE MAIN VALVE COVER AND PILOT SYSTEM AT ALL HIGH POINTS.
- () PERIODIC CLEANING OF STRAINER (Y) IS RECOMMENDED (OPTIONAL FEATURE).
- () CV FLOW CONTROLS (8A) AND (8B) OPEN AT LEAST 4 TURNS.
- () CORRECT VOLTAGE TO SOLENOID CONTROL (5).
- () MANUAL OPERATOR OF SOLENOID CONTROL (5) DISENGAGED.
- () LIMIT SWITCH ASSEMBLY (6) PROPERLY WIRED.
- () CK2 COCKS (B1), (B2), AND (B3) OPEN (OPTIONAL FEATURE).
- () CK2 COCKS (7).

LTR	DESCRIPTION	BY	DATE
	SEE SHEET 1		

CAD REVISION RECORD - DO NOT REVISE MANUALLY

Hy-Check Valve

- Built-in Automatic Check Valve
- Drip Tight, Positive Seating
- Globe or Angle Pattern
- Service Without Removal From Line
- Every valve factory-tested

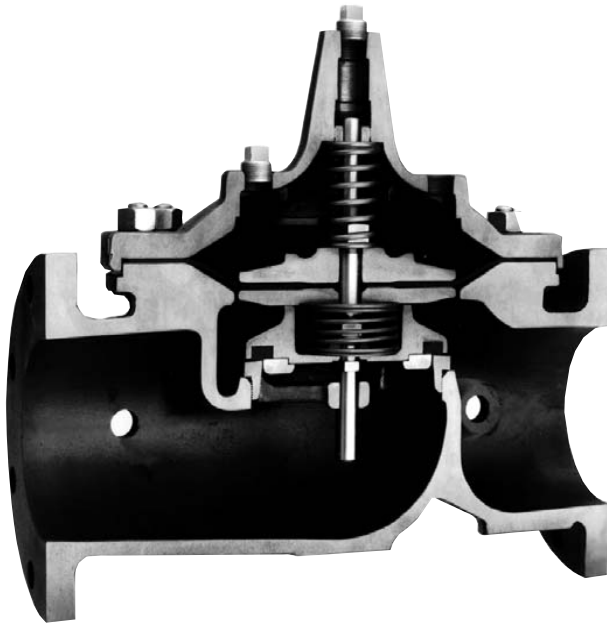

The Cla-Val Model 100-04 Hy-Check Valve is a hydraulically operated diaphragm valve with a built-in check feature to prevent return flow. Available in globe or angle pattern, it consists of a body, cover and diaphragm assembly. The diaphragm assembly which is guided top and bottom by a precision machined stem is the only moving part.

A synthetic rubber disc retained on three and one half sides forms a drip-tight seal with the renewable seat when operating pressure is applied above the non-wicking diaphragm. When pressure above the diaphragm is relieved, the valve opens wide. The rate of closing or opening can be controlled by modulating the flow into or out of the cover chamber. When a pressure reversal occurs the split stem will immediately allow the disc retainer assembly to check closed **regardless of the position of the diaphragm.**

The Model 100-04 is used on system applications such as remote control, pressure regulation, solenoid control, etc.; wherever a positive check feature is necessary to prevent reverse flow. Its packless construction and simplicity of design minimizes maintenance and assures a long dependable service life.

Principle of Operation

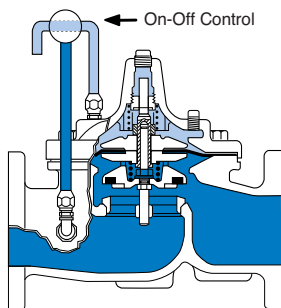

Full Open Operation

When pressure in the cover chamber is relieved to a zone of lower pressure, the line pressure at the valve inlet opens the valve, allowing full flow.

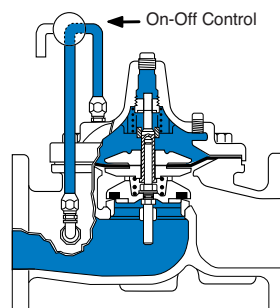

Tight Closing Operation

When pressure from the valve inlet is applied to the cover chamber, the valve closes drip-tight.

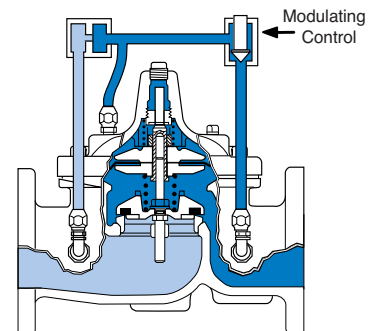

Check Action

When a static condition or pressure reversal occurs, the split stem design allows the valve to instantly check closed. Return flow is prevented regardless of the diaphragm's position.

Note: For optimum operation of built-in check feature, installation with stem vertically up is recommended.

Specifications

Model 100-04

Available Sizes

Pattern	Flanged
Globe	2" - 16"
Angle	3" - 16"

Operating Temp. Range

Fluids
-40° to 180° F

Pressure Ratings (Recommended Maximum Pressure - psi)

Valve Body & Cover		Pressure Class			
		Flanged		Threaded	
Grade	Material	ANSI Standards*	150 Class	300 Class	End‡ Details
ASTM A536	Ductile Iron	B16.42	250	400	400
ASTM A216-WCB	Cast Steel	B16.5	285	400	400
ASTM B62	Bronze	B16.24	225	400	400

Note: * ANSI standards are for flange dimensions only.
 Flanged valves are available faced but not drilled.
 ‡ End Details machined to ANSI B2.1 specifications.
Valves for higher pressure are available; consult factory for details

Materials

Component	Standard Material Combinations		
Body & Cover	Ductile Iron	Cast Steel	Bronze
Available Sizes	2" - 16"	2" - 16"	2" - 16"
Disc Retainer & Diaphragm Washer	Cast Iron	Cast Steel	Bronze
Trim: Disc Guide, Seat & Cover Bearing	Bronze is Standard Stainless Steel is optional		
Disc	Buna-N® Rubber		
Diaphragm	Nylon Reinforced Buna-N® Rubber		
Stem, Nut & Spring	Stainless Steel		

For material options not listed, consult factory.
 Cla-Val manufactures valves in more than 50 different alloys.

Options

Epoxy Coating - suffix KC

This option NSF 61 Listed and FDA approved, fusion bonded epoxy coating is for use with cast iron, ductile iron or steel valves. This coating is resistant to various water conditions, certain acids, chemicals, solvents and alkalis. Epoxy coatings are applied in accordance with AWWA coating specifications C116-03.

Do not use with temperatures above 175° F

Viton® Rubber Parts - suffix KB

Optional diaphragm, disc and o-ring fabricated with Viton® synthetic rubber. Viton® is well suited for use with mineral acids, salt solutions, chlorinated hydrocarbons, and petroleum oils; and is primarily used in high temperature applications up to 250° F. Do not use with epoxy coating above 175°F.

For assistance in selecting appropriate valve options or valves manufactured with special design requirements, please contact our Regional Sales Office or Factory.

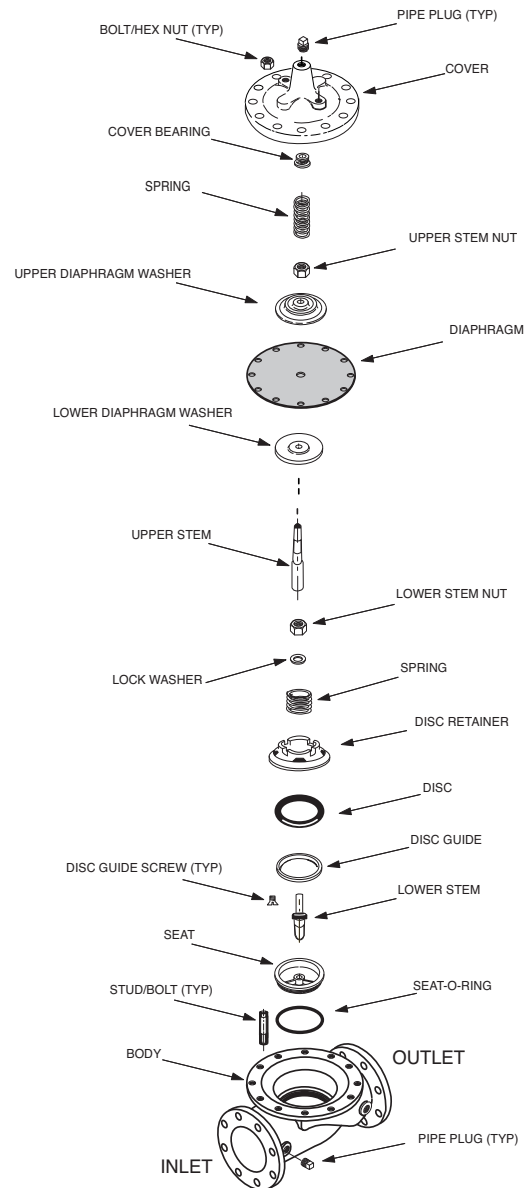

Valve Size		Inches	2	3	4	6	8	10	12	14	16
		mm.	50	80	100	150	200	250	300	350	400
C _V Factor	Globe Pattern	Gal./Min. (gpm.)	54	115	200	440	770	1245	1725	2300	2940
		Litres/Sec. (l/s.)	13	27.6	48	105.6	184.8	299	414	552	706
	Angle Pattern	Gal./Min. (gpm.)	61	139	240	541	990	1575	2500*	3060*	4200*
		Litres/Sec. (l/s.)	14.6	33.4	58	130	238	378	600	734.4	1008
Equivalent Length of Pipe	Globe Pattern	Feet (ft.)	51	85	116	211	291	347	467	422	503
		Meters (m.)	15.5	25.9	35.3	64.2	88.6	105.8	142.4	128.6	153.6
	Angle Pattern	Feet (ft.)	40	58	80	139	176	217	222*	238*	247*
		Meters (m.)	12.1	17.8	24.5	42.5	53.6	66.1	67.8	72.7	75.2
K Factor	Globe Pattern		5.6	6.0	5.9	6.2	6.1	5.8	6.1	5.0	5.2
	Angle Pattern		4.4	4.1	4.1	4.1	3.7	3.6	2.9	2.8	2.6
Liquid Displaced from Cover Chamber When Valve Opens		Fl. Oz	—	—	—	—	—	—	—	—	—
		U.S. Gal.	0.3	.08	.17	.53	1.26	2.51	4.0	6.5	9.6
		ml	121	303	643	—	—	—	—	—	—
		Litres	—	—	—	2.0	4.8	9.5	15.1	24.6	36.2

*Estimated

C_V Factor

Formulas for computing C_V Factor, Flow (Q) and Pressure Drop (ΔP):

$$C_V = \frac{Q}{\sqrt{\Delta P}} \quad Q = C_V \sqrt{\Delta P} \quad \Delta P = \left(\frac{Q}{C_V}\right)^2$$

K Factor (Resistance Coefficient)

The Value of K is calculated from the formula: $K = \frac{894d^4}{C_V^2}$ (U.S. system units)

Equivalent Length of Pipe

Equivalent lengths of pipe (L) are determined from the formula: $L = \frac{Kd}{12f}$ (U.S. system units)

Fluid Velocity

Fluid velocity can be calculated from the following formula: $V = \frac{.4085 Q}{d^2}$ (U.S. system units)

Where:

C_V = U.S. (gpm) @ 1 psi differential at 60° F water or

= (l/s) @ 1 bar (14.5 PSIG) differential at 15° C water

d = inside pipe diameter of Schedule 40 Steel Pipe (inches)

f = friction factor for clean, new Schedule 40 pipe (dimensionless) (from Cameron Hydraulic Data, 18th Edition, P 3-119)

K = Resistance Coefficient (calculated)

L = Equivalent Length of Pipe (feet)

Q = Flow Rate in U.S. (gpm) or (l/s)

V = Fluid Velocity (feet per second) or (meters per second)

ΔP = Pressure Drop in (psi) or (bar)

Model 100-04 Flow Chart (Based on normal flow through a wide open valve)

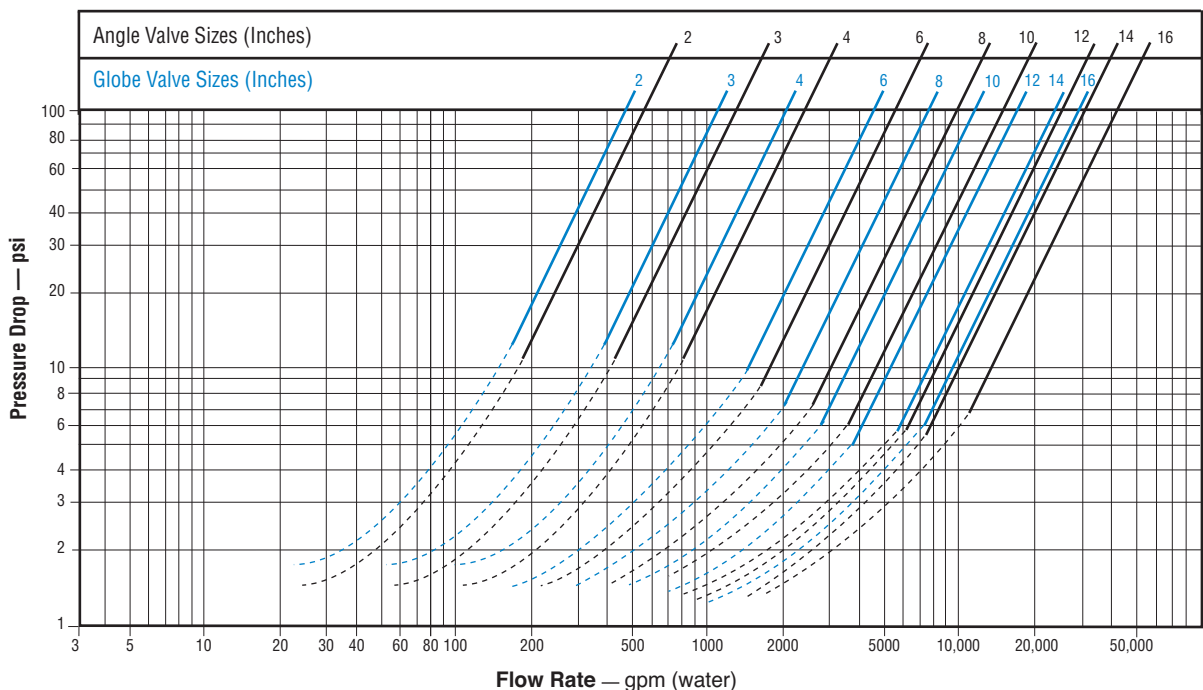

Dimensions

Model 100-04

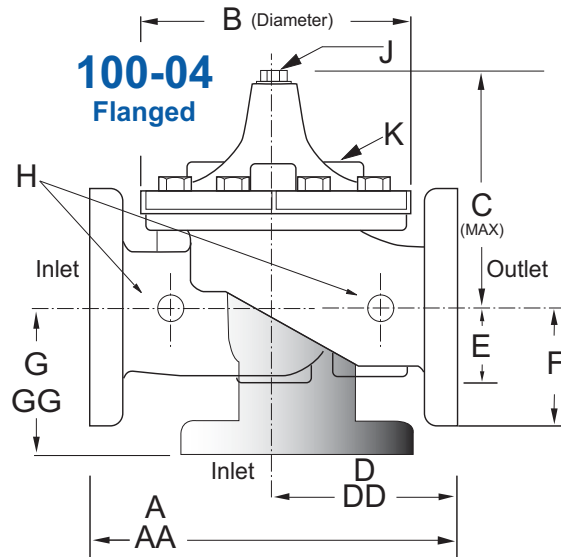

Valve Size (Inches)	2	3	4	6	8	10	12	14	16
A 150 ANSI	9.38	12.00	15.00	20.00	25.38	29.75	34.00	39.00	41.38
AA 300 ANSI	10.00	13.25	15.62	21.00	26.38	31.12	35.50	40.50	43.50
B Dia.	6.62	9.12	11.50	15.75	20.00	23.62	28.00	32.75	35.50
C Max.	6.50	8.19	10.62	13.38	16.00	17.12	20.88	24.19	25.00
D 150 ANSI	4.75	6.00	7.50	10.00	12.69	14.88	17.00	19.50	20.69
DD 300 ANSI	5.00	6.38	7.81	10.50	13.19	15.56	17.75	20.25	21.75
E	1.50	2.56	3.19	4.31	5.31	9.25	10.75	12.62	15.50
F 150 ANSI	2.50	3.75	4.50	5.50	6.75	8.00	9.50	10.50	11.75
FF 300 ANSI	3.25	4.13	5.00	6.25	7.50	8.75	10.25	11.50	12.75
G 150 ANSI	3.25	4.00	5.00	6.00	8.00	8.62	13.75	14.88	15.69
GG 300 ANSI	3.25	4.38	5.31	6.50	8.50	9.31	14.50	15.62	16.50
H NPT Body Tapping	.375	.50	.75	.75	1	1	1	1	1
J NPT Cover Center Plug	.50	.50	.75	.75	1	1	1.25	1.50	2
K NPT Cover Tapping	.375	.50	.75	.75	1	1	1	1	1
Valve Stem Internal Thread UNF	10-32	¼-28	¼-28	¾-24	¾-24	¾-24	¾-24	¾-24	¾-20
Stem Travel	0.6	0.8	1.1	1.7	2.3	2.8	3.4	4.0	4.5
Approx. Ship Wt. Lbs.	35	70	140	285	500	780	1165	1500	2265

Valve Size (mm)	50	80	100	150	200	250	300	350	400
A 150 ANSI	238	305	381	508	645	756	864	991	1051
AA 300 ANSI	254	337	397	533	670	790	902	1029	1105
B Dia.	168	232	292	400	508	600	711	832	902
C Max.	165	208	270	340	406	435	530	614	635
D 150 ANSI	121	152	191	254	322	378	432	495	526
DD 300 ANSI	127	162	200	267	335	395	451	514	552
E	38	65	81	109	135	235	273	321	394
F 150 ANSI	76	95	114	140	171	203	241	267	298
FF 300 ANSI	83	105	127	159	191	222	260	292	324
G 150 ANSI	83	102	127	152	203	219	349	378	399
GG 300 ANSI	89	111	135	165	216	236	368	397	419
H NPT Body Tapping	.375	.50	.75	.75	1	1	1	1	1
J NPT Cover Center Plug	.50	.50	.75	.75	1	1	1.25	1.50	2
K NPT Cover Tapping	.375	.50	.75	.75	1	1	1	1	1
Valve Stem Internal Thread UNF	10-32	¼-28	¼-28	¾-24	¾-24	¾-24	¾-24	¾-24	¾-20
Stem Travel	15	20	28	43	58	71	86	102	114
Approx. Ship Wt. Kgs.	16	32	64	129	227	354	528	726	1027

Service

Cla-Val Control Valves operate with maximum efficiency when mounted in horizontal piping with the main valve cover UP, however, other positions are acceptable. Due to component size and weight of 8 inch and larger valves, installation with cover UP is advisable. We recommend isolation valves be installed on inlet and outlet for maintenance. Adequate space above and around the valve for service personnel should be considered essential. A regular maintenance program should be established based on the specific application data. However, we recommend a thorough inspection be done at least once a year. Consult factory for specific recommendations.

REVISIONS

NO.	DESCRIPTION	DATE	APPROVED
1	ISSUE REVISION FILE		
2	REVISION FILE		
3	REVISION FILE		
4	REVISION FILE		
5	REVISION FILE		
6	REVISION FILE		
7	REVISION FILE		
8	REVISION FILE		
9	REVISION FILE		
10	REVISION FILE		
11	REVISION FILE		
12	REVISION FILE		
13	REVISION FILE		
14	REVISION FILE		
15	REVISION FILE		
16	REVISION FILE		
17	REVISION FILE		
18	REVISION FILE		
19	REVISION FILE		
20	REVISION FILE		
21	REVISION FILE		
22	REVISION FILE		
23	REVISION FILE		
24	REVISION FILE		
25	REVISION FILE		
26	REVISION FILE		
27	REVISION FILE		
28	REVISION FILE		
29	REVISION FILE		
30	REVISION FILE		
31	REVISION FILE		
32	REVISION FILE		
33	REVISION FILE		
34	REVISION FILE		
35	REVISION FILE		
36	REVISION FILE		
37	REVISION FILE		
38	REVISION FILE		
39	REVISION FILE		
40	REVISION FILE		
41	REVISION FILE		
42	REVISION FILE		
43	REVISION FILE		
44	REVISION FILE		
45	REVISION FILE		
46	REVISION FILE		
47	REVISION FILE		
48	REVISION FILE		
49	REVISION FILE		
50	REVISION FILE		

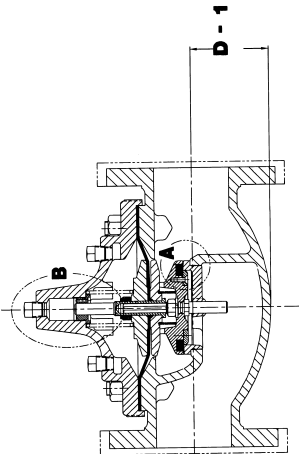

D-1
4" SIZE SHOWN
100-04 HY-CHECK (GLOBE)

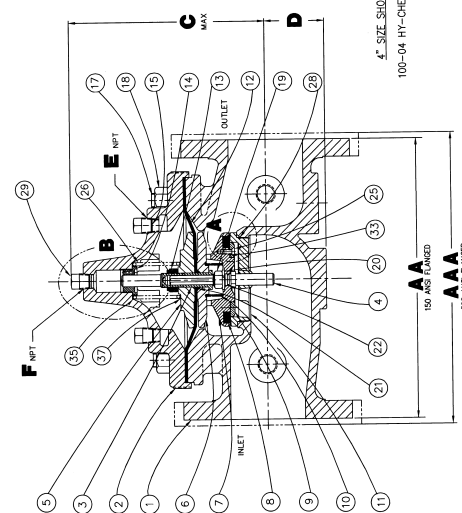
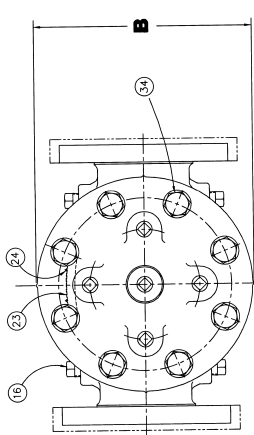

A
4" SIZE SHOWN
100-04 HY-CHECK (GLOBE)

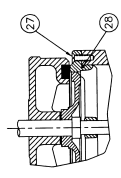

SEAT AND DISC DETAIL
8" AND LARGER
DETAIL A

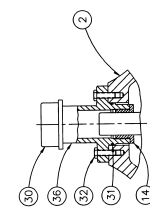

COVER BEARING HOUSING DETAIL
1/2" SIZE ONLY
DETAIL B

VALVE SIZES	DIMENSION TABLE										
	1/2"	3/4"	1"	1 1/2"	2"	3"	4"	6"	8"	10"	12"
AA	5.38	11.61	12.80	15.00	20.00	25.38	29.75	34.00	39.00	41.38	
AAA	10.00	11.62	13.25	15.82	21.00	26.38	31.75	35.50	40.50	43.50	
DA	6.62	8.00	9.12	11.50	15.75	20.00	23.82	28.00	32.75	35.50	
CA	6.50	7.58	8.19	10.62	13.38	16.00					
DB	1.50	1.69	2.06	3.19	4.31	5.31					
DC	2.50	2.88	3.12	4.25	6.00	7.58	9.25	10.75	12.62	15.50	
DE	3/8"	1/2"	1/2"	3/4"	3/4"	1"	1"	1"	1"	1"	
DF	NPT	1/2"	1/2"	1/2"	3/4"	3/4"	1"	1"	1-1/4"	1-1/2"	2"

NO.	DESCRIPTION	DATE	APPROVED
1	ISSUE REVISION FILE		
2	REVISION FILE		
3	REVISION FILE		
4	REVISION FILE		
5	REVISION FILE		
6	REVISION FILE		
7	REVISION FILE		
8	REVISION FILE		
9	REVISION FILE		
10	REVISION FILE		
11	REVISION FILE		
12	REVISION FILE		
13	REVISION FILE		
14	REVISION FILE		
15	REVISION FILE		
16	REVISION FILE		
17	REVISION FILE		
18	REVISION FILE		
19	REVISION FILE		
20	REVISION FILE		
21	REVISION FILE		
22	REVISION FILE		
23	REVISION FILE		
24	REVISION FILE		
25	REVISION FILE		
26	REVISION FILE		
27	REVISION FILE		
28	REVISION FILE		
29	REVISION FILE		
30	REVISION FILE		
31	REVISION FILE		
32	REVISION FILE		
33	REVISION FILE		
34	REVISION FILE		
35	REVISION FILE		
36	REVISION FILE		
37	REVISION FILE		
38	REVISION FILE		
39	REVISION FILE		
40	REVISION FILE		
41	REVISION FILE		
42	REVISION FILE		
43	REVISION FILE		
44	REVISION FILE		
45	REVISION FILE		
46	REVISION FILE		
47	REVISION FILE		
48	REVISION FILE		
49	REVISION FILE		
50	REVISION FILE		

NOTES:
1. FOR PRESSURE, MATERIAL, VALVE MUST BE INSTALLED IN A HORIZONTAL POSITION.
2. USE WITH COVER AND STEM IN A VERTICAL POSITION.

NO.	DESCRIPTION	DATE	APPROVED
1	ISSUE REVISION FILE		
2	REVISION FILE		
3	REVISION FILE		
4	REVISION FILE		
5	REVISION FILE		
6	REVISION FILE		
7	REVISION FILE		
8	REVISION FILE		
9	REVISION FILE		
10	REVISION FILE		
11	REVISION FILE		
12	REVISION FILE		
13	REVISION FILE		
14	REVISION FILE		
15	REVISION FILE		
16	REVISION FILE		
17	REVISION FILE		
18	REVISION FILE		
19	REVISION FILE		
20	REVISION FILE		
21	REVISION FILE		
22	REVISION FILE		
23	REVISION FILE		
24	REVISION FILE		
25	REVISION FILE		
26	REVISION FILE		
27	REVISION FILE		
28	REVISION FILE		
29	REVISION FILE		
30	REVISION FILE		
31	REVISION FILE		
32	REVISION FILE		
33	REVISION FILE		
34	REVISION FILE		
35	REVISION FILE		
36	REVISION FILE		
37	REVISION FILE		
38	REVISION FILE		
39	REVISION FILE		
40	REVISION FILE		
41	REVISION FILE		
42	REVISION FILE		
43	REVISION FILE		
44	REVISION FILE		
45	REVISION FILE		
46	REVISION FILE		
47	REVISION FILE		
48	REVISION FILE		
49	REVISION FILE		
50	REVISION FILE		

100-04 HY-CHECK 2" - 16"
150 LB AND 300 LB
84194
100-04 HY-CHECK 2" - 16"
150 LB AND 300 LB
84194
100-04 HY-CHECK 2" - 16"
150 LB AND 300 LB
84194

100-04 HY-CHECK 2" - 16"
150 LB AND 300 LB
84194
100-04 HY-CHECK 2" - 16"
150 LB AND 300 LB
84194
100-04 HY-CHECK 2" - 16"
150 LB AND 300 LB
84194

100-04 HY-CHECK 2" - 16"
150 LB AND 300 LB
84194
100-04 HY-CHECK 2" - 16"
150 LB AND 300 LB
84194
100-04 HY-CHECK 2" - 16"
150 LB AND 300 LB
84194

100-04 HY-CHECK 2" - 16"
150 LB AND 300 LB
84194
100-04 HY-CHECK 2" - 16"
150 LB AND 300 LB
84194
100-04 HY-CHECK 2" - 16"
150 LB AND 300 LB
84194

100-04 HY-CHECK 2" - 16"
150 LB AND 300 LB
84194
100-04 HY-CHECK 2" - 16"
150 LB AND 300 LB
84194
100-04 HY-CHECK 2" - 16"
150 LB AND 300 LB
84194

100-04 HY-CHECK 2" - 16"
150 LB AND 300 LB
84194
100-04 HY-CHECK 2" - 16"
150 LB AND 300 LB
84194
100-04 HY-CHECK 2" - 16"
150 LB AND 300 LB
84194



60 Series Booster Pump Control Valves - Electrical Controls

Note:

Please refer to Cla-Val. drawing #69548, the Product Data Catalog and the Installation, Operation, & Maintenance Manual shipped with the Control Valve.

Start Up Procedure

The limit switch (SW2) on the valve should be adjusted before the pump control valve is placed in service. The stop collar on the limit switch stem should be adjusted to strike the switch arm roller as the valve travels closed to the 95% (approx.) closed position. The N.O. contacts on the SW2 limit switch will close when the adjustable collar strikes the limit switch roller and moves the switch arm.

Please read the operating instructions carefully. Make all adjustments (opening speed control, closing speed control and limit switch) before starting the booster pump or turning on the electrical control power.

Pump Starting - Pump Running Cycle

There are two ways in which the pump motor (M) starting cycle may be “called” on:

1 - The pump motor may be “called” on by manually placing the H-O-A switch in the hand position. This action bypasses the automatic remote switch (SW1) and calls the pump on.

2 - The pump motor may be “called” on by manually placing the H-O-A switch in the “automatic” position provided that the automatic switch (SW1) contacts close. This action places the pump motor under the command of SW1 and the associated safety controls. The pump motor (M) can not be called on, under any conditions, if the H-O-A

After the above adjustments have been made the H-O-A switch should be placed in the “off” position and the electrical control power should be turned on. The 60 Series control valve should then be permitted to close (please see manual) and allow the limit switch (SW2) stop collar to contact the SW2 switch roller. This action closes the N.O. contacts on SW2 and energizes the coil on relay 3CR.

The H-O-A switch can now be placed in the “automatic” position and the following operation should result:

switch is manually placed in the “off” position.

When SW1 contacts close (assuming that 3CR coil is energized—see start up procedure above) coil 1CR is energized, both contacts 1CR close to energize pilot valve solenoid (PVS) and relay coil 2CR. Both contacts 2CR close and the pump motor (M) starts immediately as the valve begins to open. As the limit switch SW2 stem collar lifts off the roller, SW2 contacts N.C., close. The pump is now locked on the line by SW2 and the valve slowly continues to go completely open, directing all liquid flow to the pipeline.

Power Failure (While Pump Is Running) Conditions

If a momentary power failure should occur while the pump is running, relay coil 3CR would be de-energized and contacts 3CR₁, 3CR₂, and 3CR₃ would open. This action would completely lock the pump motor out from restarting and keep the valve solenoid PVS de-energized until the diaphragm assembly lowers to the setpoint of SW2 limit switch. The Cla-Val 60 Series valve is equipped with an integral “drop” check that will close immediately

when the pump motor stops and prevent backflow. However, a time period of several seconds is required for the diaphragm assembly to travel to the down position to hold the valve closed when the pump restarts. Thus, even though the power is restored immediately following the power failure the pump cannot restart until the system is “ready”, hydraulically, for a new start up.

Pump Stopping - Pump Off Conditions

When SW1 contacts are opened, or the H-O-A switch is manually placed in the off position, coil 1CR contacts open and the PVS coil is de-energized. Since the SW2 contacts are in the normally closed position the pump motor (M) continues to run as the pump control valve slowly closes. When the SW2 stop collar reaches the roller arm, the SW2

N.C. contacts will open, 2CR coil will be de-energized, both 2CR contacts will open and the pump motor (M) will stop. The pump motor will remain off under these conditions. Coil 3 CR will remain energized and contacts 3CR₁, 3CR₂, and 3CR₃ will remain closed. The Cla-Val 60 Series will remain closed under these conditions.



Pressure Relief Control

DESCRIPTION

The CRL Pressure Relief Control is a direct acting, spring loaded, diaphragm type relief valve. It may be used as a self-contained valve or as a pilot control for a Cla-Val Main valve. It opens and closes within very close pressure limits.

INSTALLATION

The CRL Pressure Relief Control may be installed in any position. The control body (7) has one inlet and one outlet port with a side pipe plug (24) at each port. These plugs are used for control connections or gauge applications. The inlet in the power unit body (6) is the sensing line port. A flow arrow is marked on the body casting.

OPERATION

The CRL Pressure Relief Control is normally held closed by the force of the compression spring above the diaphragm; control pressure is applied under the diaphragm.

When the controlling pressure exceeds the spring setting, the disc is lifted off its seat, permitting flow through the control.

When controlling pressure drops below spring setting, the spring returns the control to its normally closed position.

ADJUSTMENT PROCEDURE

The CRL Pressure Relief Control can be adjusted to provide a relief setting at any point within the range found on the nameplate.

Pressure adjustment is made by turning the adjustment screw (9) to vary the spring pressure on the diaphragm. Turning the adjustment screw clockwise increases the pressure required to open the valve. Counterclockwise decreases the pressure required to open the valve.

When pressure adjustments are complete the jam nut (10) should be tightened and the protective cap (1) replaced. If there is a problem of tampering, lock wire holes have been provided in cap and cover. Wire the cap to cover and secure with lead seal.

DISASSEMBLY

The CRL Pressure Relief Control does not need to be removed from the line for disassembly. Make sure that pressure shut down is accompanied prior to disassembly. If the CRL is removed from the line for disassembly be sure to use a soft jawed vise to hold body during work.

Refer to Parts List Drawing for Item Numbers.

1. Remove cap (1), loosen jam nut (10) and turn adjusting screw counterclockwise until spring tension is relieved.
2. Remove the eight screws (4) holding the cover (3) and powerunit body (6). Hold the cover and powerunit together and place on a suitable work surface.
See NOTE under REASSEMBLY.
3. Remove the cover (3) from powerunit body (6). The spring (12) and two spring guides (11).
4. Remove nut (13) from stem (19) and slide off the belleville washer (14), the upper diaphragm washer (15) and the diaphragm (16).
5. Pull the stem (19) with the disc retainer assembly (21) through the bottom of powerunit. The lower diaphragm washer (17) will slide off of stem top.
6. Remove jam nut (23) and disc retainer assembly (21) from stem. Use soft jawed pliers or vise to hold stem. The polished surface of stem must not be scored or scratched.
7. The seat (22) need not be removed unless it is damaged. If removal is necessary use proper size socket wrench and turn counterclockwise.

Note: Some models have an integral seat in the body (7).

INSPECTION

Inspect all parts for damage, or evidence of cross threading. Check diaphragm and disc retainer assembly for tears, abrasions or other damage. Check all metal parts for damage, corrosion or excessive wear.

REPAIR AND REPLACEMENT

Minor nicks and scratches may be polished out using 400 grit wet or dry sandpaper fine emery or crocus cloth. Replace all O-rings and any damaged parts.

When ordering replacement parts, be sure to specify parts list item number and all nameplate data.

REASSEMBLY

In general, reassembly is the reverse of disassembly. However, the following steps should be observed:

1. Lubricate the O-Ring (18) with a small amount of a good grade of waterproof grease, (Dow Corning 44 medium grade or equal). Use grease sparingly and install O-ring in powerunit body (6).
2. Install stem (19) in powerunit body (6). Use a rotating motion with minimum pressure to let stem pass through O-ring.
Do Not Cut O-Ring.
3. Install O-ring (5) at top of stem (19). Place lower diaphragm washer (17) on the stem with the serrated side up. Position diaphragm (16), upper diaphragm washer (15), with serration down, and belleville washer (14) with concave side down.
4. Position powerunit body (6) as shown on parts list drawing (top view).
5. Continue reassembly as outlined in disassembly steps 1 through 3.

Note: Item (4) Screw will have a quantity of 8 for the 0-75 and 20-200psi design and a quantity of 4 for the 100-300psi design. Item (25) Screw is used on the 100-300psi design only. Install item (25), before item (4) for preload of item (12) spring.

SYMPTOM	PROBABLE CAUSE	REMEDY
Fails to open.	Controlling pressure too low.	Back off adjusting screw until valve opens.
Fails to open with spring compression removed.	Mechanical obstruction, corrosion, scale build-up on stem.	Disassemble, locate, and remove obstruction, scale.
Leakage from cover vent hole when controlling pressure is applied.	Diaphragm Damage	Disassembly replace damaged diaphragm.
	Loose diaphragm assembly.	Tighten upper diaphragm washer.
Fails to close.	No spring compression.	Re-set pressure adjustment.
Fails to close with spring compressed.	Mechanical obstruction.	Disassemble, locate and remove obstruction.



1/2" & 3/4" PRESSURE RELIEF CONTROL

(Bronze Body with 303SS Trim)

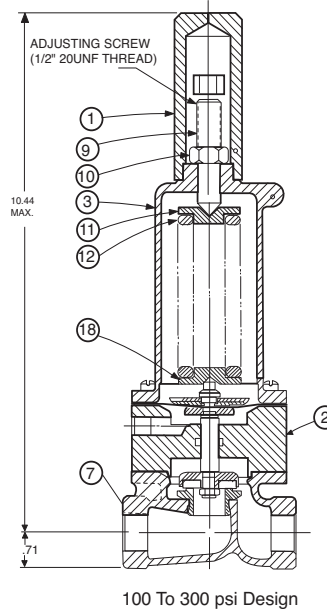
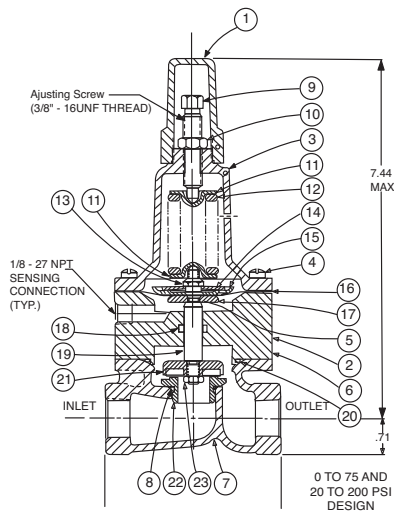
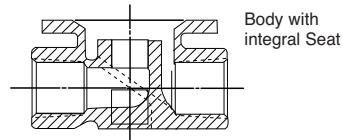
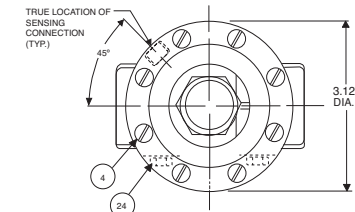

SIZE	SPRING	PART NUMBER
1/2"	0-75 PSI	7922201E
1/2"	20-105 PSI	7922205F
1/2"	20-200 PSI	7922202C
1/2"	100-300 PSI	8280901D
3/4"	0-75 PSI	7922901K
3/4"	20-105 PSI	7922903F
3/4"	20-200 PSI	7922902H
3/4"	100-300 PSI	8600501E

For 250-600 PSI Contact Factory

CRL Range PSI	APPROX. INCREASE FOR EACH CLOCKWISE TURN OF ADJUSTING SCREW
0 to 75	8.5 PSI
20 to 105	12.5 PSI
20 to 200	28.0 PSI
100 to 300	18.0 PSI

When ordering parts please specify:

1. All Nameplate Data
2. Item Part Number
3. Item Description

Item	Description	Material	Part Number			
			0-75	20-105	20-200	100-300
1	Cap	Plastic	67628J	67628J	67628J	1257601D
2	Nameplate	Brass	--	--	--	--
3	Cover	Bronze	C2544K	C2544K	C2544K	44587E
4*	Screw Fil. Hd. 10-32 x 1.88 (Qty 8)	303 SS	6757867E	6757867E	6757867E	6757867E
5*	O-Ring	Rubber	00902H	00902H	00902H	00902H
6	Body, Powerunit	Bronze	7920504D	7920504D	7920504D	7920504D
7	1/2" Body	Bronze	C7928K	C7928K	C7928K	C7928K
	3/4" Body	Bronze	C9083B	C9083B	C9083B	C9083B
8*	O-Ring, Seat	Rubber	00718H	00718H	00718H	00718H
9	Screw, Adjusting	Brass	7188201D	7188201D	7188201D	82811B
10	Nut Hex (Locking)	303 SS	6780106J	6780106J	6780106J	6780606H
11	Guide, Spring	303 SS	71881H	71881H	71881H	1630301J
12	Spring	CHR/VAN	71884B	20632101E	71885J	1630201A
13	Nut, Stem Upper	Bronze	73034B	73034B	73034B	73034B
14	Washer, Belleville	Steel	7055007E	7055007E	7055007E	7055007E
15	Washer, Diaphragm (upper)	303 SS	71891G	71891G	71891G	71891G
16*	Diaphragm	Rubber	C1505B	C1505B	C1505B	C1505B
17	Washer, Diaphragm (lower)	303 SS	45871B	45871B	45871B	45871B
18*	O-Ring, Stem	Rubber	00746J	00746J	00746J	00746J
19	Stem	303 SS	8982401F	8982401F	8982401F	8982401F
20*	O-Ring, Body	Rubber	00767E	00767E	00767E	00767E
21*	Retainer Assembly, Disc	303 SS	C9158B	C9158B	C9158B	C9158B
22	Seat	303Rub	62187A	62187A	62187A	62187A
23	Nut, Hex, Stem, Lower	Bronze	6779806G	6779806G	6779806G	6779806G
24	Pipe Plug	Bronze	6784701C	6784701C	6784701C	6784701C
	FACTORY SET POINT		50 PSI	60 PSI	60 PSI	100 PSI
	REPAIR KIT*		9170007A	9170007A	9170007A	9170007A



—MODEL —

100-01

3/8"-1 Hytrol Valve

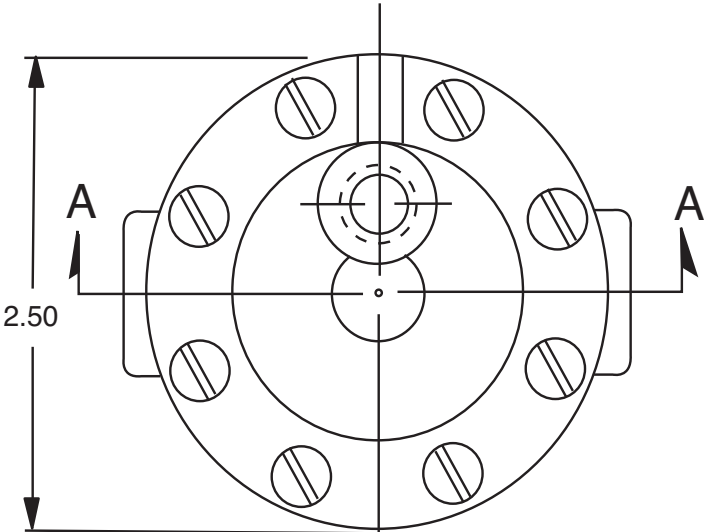

PARTS LIST

ITEM	DESCRIPTION
1.	Cover Screw (8 Required)
2.	Cover
3.	Spring
4.	Diaphragm Washer
* 5.	Diaphragm
* 6.	Disc Retainer Assembly
7.	Body Plug (3/8 NPT)
8.	Body

* Recommended Spare Parts

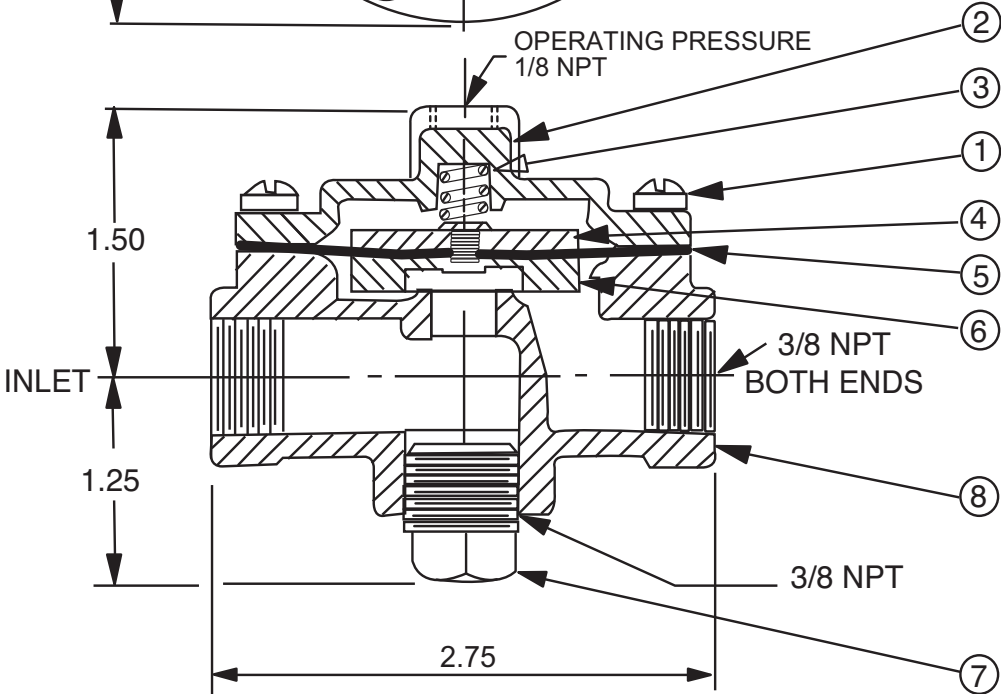

SECTION AA

100-01 3/8" HYTROL VALVE

When Ordering parts, please specify

- All nameplate data
- Description
- Item Number
- Material

—MODEL— **100-01**

1/2"-3/4"-1" Hytrol Valve

100-01 3/4" & 1/2" Hytrol Valve

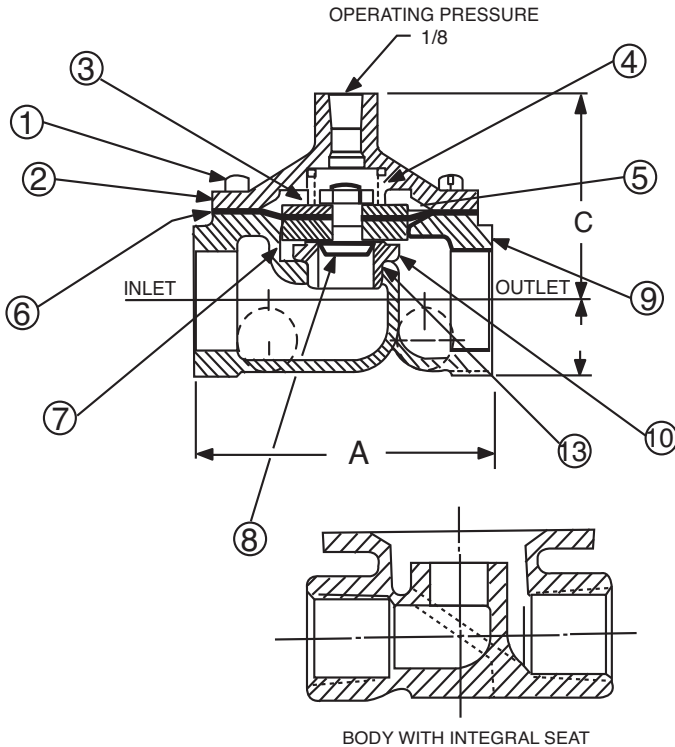

PARTS LIST

ITEM	DESCRIPTION
1	COVER SCREW
2	COVER
3	SPRING
4	STEM NUT
5	DIAPHRAGM WASHER
* 6	DIAPHRAGM
* 7	DISC RETAINER ASSEMBLY
8	DISC GUIDE & STEM
9	BODY
10	SEAT
11	NAMEPLATE
12	BODY PLUG HEX HD.
13	O-RING SEAT (FOR OLD STYLE BODY ONLY)

* Recommended Spare Parts

	1/2	3/4
A	1-7/16	3-1/2
C (MAXIMUM)	2-3/8	2-3/8
D	25/32	29/32

When Ordering parts, please specify

- All nameplate data
- Description
- Item Number
- Material

100-01 1" Hytrol Valve

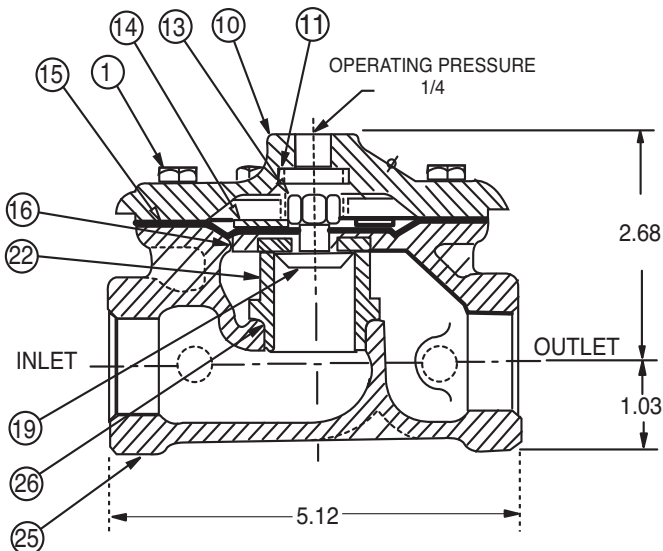

PARTS LIST

ITEM	DESCRIPTION
1	COVER SCREW
2	NAMEPLATE
3	NAMEPLATE SCREW
10	COVER
11	SPRING
13	STEM NUT
14	DIAPHRAGM WASHER
15	DIAPHRAGM
16	DISC RETAINER ASSEMBLY
19	DISC GUIDE
22	SEAT
24	BODY PLUG
25	BODY
26	O-RING, SEAT

* Recommended Spare Parts

INSTALLATION AND MAINTENANCE INSTRUCTIONS

3-WAY SOLENOID VALVES, NORMALLY OPEN NORMALLY CLOSED AND UNIVERSAL CONSTRUCTION

**BULLETIN
8320**

ASCO
FORM NO. V5291R2

DESCRIPTION

Bulletin 8320 is a small 3-way solenoid operated valve with all three pipe connections located in the body. The bodies are of brass or stainless steel construction. Standard valves have General Purpose, Nema Type 1 Solenoid Enclosures. Valves that are equipped with a solenoid enclosure which is designed to meet Nema Type 4-Water tight, Nema Type 7 (C or D) Hazardous Locations - Class I, Group C or D, and Nema Type 9 (E, F or G) Hazardous Locations - Class II, Group E, F or G are shown on separate sheets of Installation and Maintenance Instructions, Form Numbers V-5391 and V-5381.

MANUAL OPERATORS (OPTIONAL)

Valves with suffix "MO" or "MS" in catalog number are provided with a Manual Operator which allows manual operation when desired or during an interruption of electrical power.

OPERATION

Normally Closed: Applies pressure when solenoid is energized; exhausts pressure when solenoid is de-energized

Normally Open: Applies pressure when solenoid is de-energized; exhausts pressure when solenoid is energized.

Universal: For normally closed or normally open operation, selection or diversion of pressure can be applied at port 1 (A), 2 (B), or 3 (C).

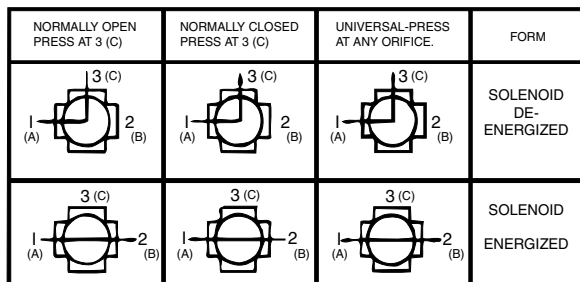

NOTE: Port Markings 1, 2, and 3 correspond directly to A, B and C.

INSTALLATION

Check Nameplate for correct Catalog Number, pressure, voltage and service.

POSITIONING

Valve may be mounted in any position

PIPING

Connect piping to valve according to markings on valve body. Refer to Flow Diagram provided. Apply pipe compound sparingly to male pipe threads only; if applied to valve threads, it may enter valve and cause operational difficulty. Pipe strain should be avoided by proper support and alignment of piping. When tightening pipe, do not use valve as lever.

IMPORTANT: For protection of the solenoid valve, install a strainer or filter suitable for the service involved in the inlet side as close to the valve as possible. Periodic cleaning is required depending on the service conditions.

WIRING

Wiring must comply with local and National Electrical Codes. For valves equipped with an explosion-proof, watertight solenoid enclosure, the electrical fittings must be approved for use in the approved hazardous locations. Housings for all solenoids are made with connections for 1/2 inch conduit. The general purpose enclosure may be rotated to facilitate wiring by removing the retaining cap.

NOTE

Alternating Current (A-C) and Direct Current (D-C) solenoids are built differently. To convert from one to other, it is necessary to change the complete solenoid, including the core assembly.

SOLENOID TEMPERATURE

Standard catalog valves are supplied with coils designed for continuous duty service. When the solenoid is energized for a long period, the solenoid enclosure becomes hot and can be touched with the bare hand for only an instant. This safe operating temperature. Any excessive heating will be indicated by the smoke and odor of burning coil insulation.

MAINTENANCE

WARNING: Turn off electrical power and line pressure to valve before making repairs. It is not necessary to remove valve from pipe line for repairs.

CLEANING

A periodic cleaning of all valves is desirable. The time between cleanings will vary, depending on the media and service conditions. In general, if the voltage to the coils is correct, sluggish valve operation or excessive leakage will indicate that cleaning is required.

IMPROPER OPERATION

1. **Faulty Control Circuit:** Check the electrical system by energizing the solenoid. A metallic click signifies the solenoid is operating. Absence of the click indicate loss of power supply. Check for loose or blown-out fuses, open-circuited or grounded coil, broken lead wires or splice.
2. **Burned-out Coil:** Check for open-circuited coil. Replace coil, if necessary.
3. **Low Voltage:** Check voltage across coil leads. Voltage must be at least 85% of nameplate ratings.
4. **Incorrect Pressure:** Check valve pressure. Pressure to valve must be within the range specified on nameplate.
5. **Excessive Leakage:** Disassemble valve and clean all parts. Replace parts that are worn or damaged with a complete Spare Parts Kit for best results.

COIL REPLACEMENT (REF. FIG. 2)

Turn off electrical power, disconnect coil lead wires and proceed as follows:

1. Remove retaining cap, nameplate and cover.
2. Slip yoke containing coil, sleeves and insulating washers off the solenoid base sub-assembly. Insulating washers are omitted when molded coil is used. In some D.C. Constructions, a single flux plate over the coil replaces yoke, sleeves and insulating washers.
3. Reassemble in reverse order of disassembly.

VALVE DISASSEMBLY AND REASSEMBLY (REF. FIG. 2)

Turn off electrical power supply and de-pressurize valve.

1. Remove retaining cap and slip entire solenoid off solenoid base subassembly or plugnut/core tube sub-assembly.
2. Unscrew bonnet or solenoid base sub-assembly. Remove core assembly, core spring and body gasket.
3. Remove end cap, body gasket, disc spring, disc holder, disc or disc holder assembly.
4. All parts are now accessible for cleaning or replacement. Replace worn or damaged parts with a complete Spare Parts Kit for best results.
5. Reassemble in reverse order of disassembly paying careful attention to exploded view provided.

ORDERING INFORMATION FOR SPARE PARTS KITS

When Ordering Spare Parts Kits or Coils
Specify Valve Catalog Number,
Serial Number and Voltage

Spare Parts Kits and Coils are available for ASCO valves. Parts marked with

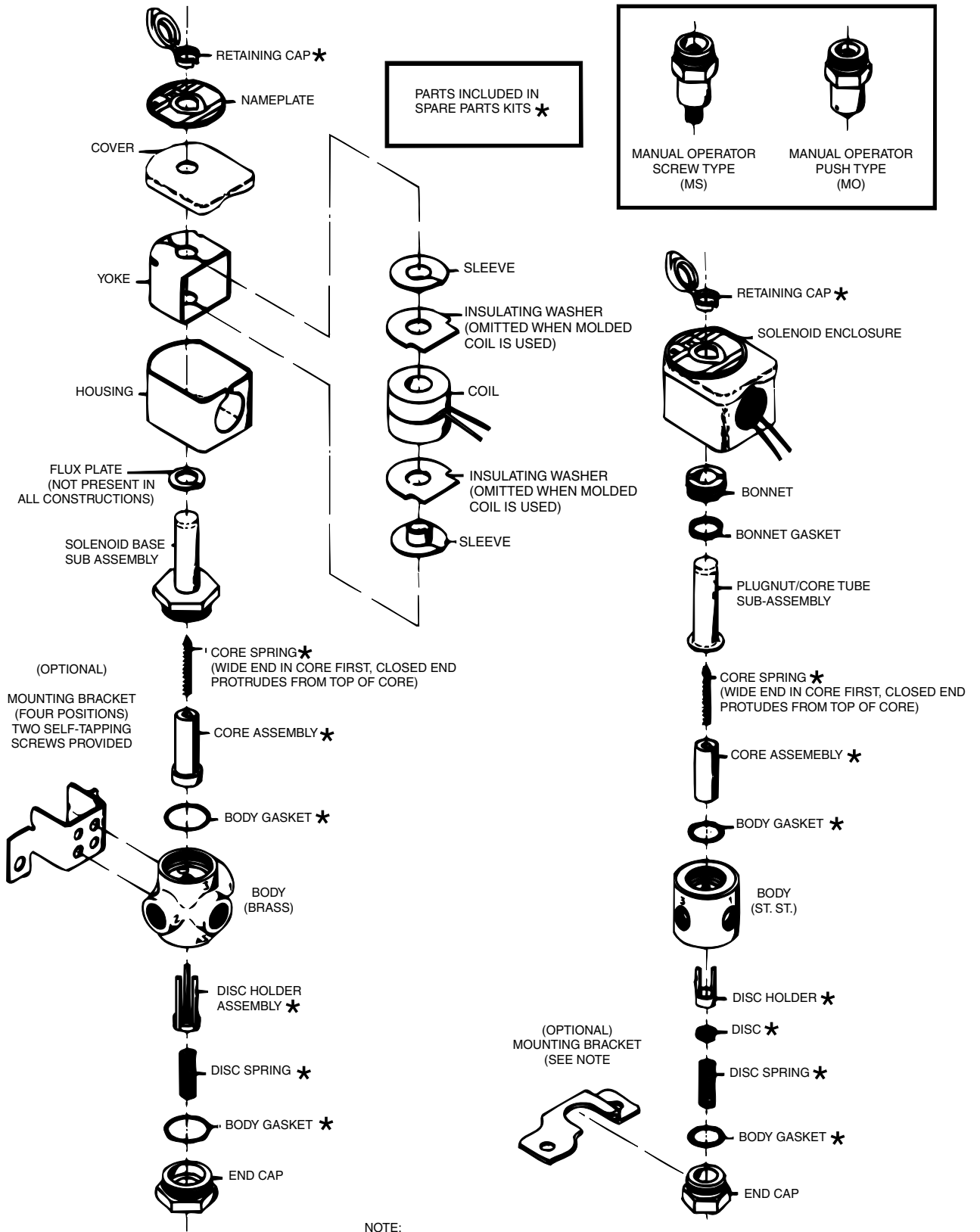

NOTE:
 1. FOR MOUNTING, A FLAT SURFACE MUST BE PROVIDED ACROSS THE ENTIRE LENGTH OF THE BRACKET. THE VALVE BODY BECOMES SECURE TO BRACKET, WHEN BRACKET IS TIGHTENED IN TO POSITION. IF THE VALVE HAS A MANUAL OPERATOR, A HOLE MUST BE MADE THROUGH THE MOUNTING SURFACE FOR THE OPERATOR STEM.

INSTALLATION AND MAINTENANCE INSTRUCTIONS

OPEN-FLAME, GENERAL PURPOSE, WATERTIGHT/EXPLOSIONPROOF SOLENOIDS

**BULLETIN
8016G**

ASCO
FORM NO. V6583R5

-SERVICE NOTICE-

ASCO® solenoid valves with design change letter "G" in the catalog number (example: 8210G 1) have an epoxy encapsulated ASCO® Red Hat II. solenoid. This solenoid replaces some of the solenoids with metal enclosures and open-frame constructions. Follow these installation and maintenance instructions if your valve or operator uses this solenoid.

DESCRIPTION

Catalog numbers 8016G1 and 8016G2 are epoxy encapsulated pull-type solenoids. The green solenoid with lead wires and 1/2" conduit connection is designed to meet Enclosure Type 1 -General Purpose, Type 2-Dripproof, Types 3 and 3S-Raintight, and Types 4 and 4X-Watertight. The black solenoid on catalog numbers prefixed "EF" is designed to meet Enclosure Types 3 and 3S-Raintight, Types 4 and 4X-Watertight, Types 6 and 6P-Submersible, type 7 (A, B, C, & D) Explosionproof Class 1, Division 1, Groups A, B, C, & D and Type 9 (E, F, & G)-Dust-Ignitionproof Class 11, Division 1, Groups E, F, & G. The Class 11, Groups F & G Dust Locations designation is not applicable for solenoids or solenoid valves used for steam service or when a class "H" solenoid is used. See Temperature Limitations section for solenoid identification and nameplate/retainer for service. When installed just as a solenoid and not attached to an ASCO valve, the core has a .250-28 UNF-2B tapped hole, 0.38 minimum full thread.

Series 8016G solenoids are available in:

- **Open-Frame Construction**
The green solenoid may be supplied with 1/4" spade, screw, or DIN terminals (Refer to Figure 4).
- **Panel Mounted Construction**
These solenoids are specifically designed to be panel mounted by the customer through a panel having a .062 to .093 maximum wall thickness. (Refer to Figure 3 and section on Installation of Panel Mounted Solenoid).

Optional Features For Type 1—General Purpose Construction Only

- **Junction Box**
This junction box construction meets Enclosure Types 2,3,3S,4, and 4X. Only solenoids with 1/4" spade or screw terminals may have a junction box. The junction box provides a 1/2" conduit connection, grounding and spade or screw terminal Connections within the junction box (See Figure 5).
- **DIN Plug Connector Kit No. K236 - 034**
Use this kit only for solenoids with DIN terminals. The DIN plug connector kit provides a two pole with grounding contact DIN Type 43650 construction (See Figure 6).

OPERATION

When the solenoid is energized, the core is drawn into the solenoid base sub-assembly. **IMPORTANT:** When the solenoid is de-energized, the initial return force for the core, Whether developed by spring, pressure, or weight, must exert a minimum force to overcome residual magnetism created by the solenoid. Minimum return force for AC construction is 11 ounces, and 4 ounces for DC construction.

INSTALLATION

Check nameplate for correct catalog number, service, and wattage. Check front of solenoid for voltage and frequency.

WARNING: To prevent the possibility of electrical shock from the accessibility of live parts, install the open-frame solenoid in an enclosure.

FOR BLACK ENCLOSURE TYPES 7 AND 9 ONLY

CAUTION: To prevent fire or explosion, do not install solenoid and/or valve where ignition temperature is less than 165° C. On valves used for steam service or when a class "H" solenoid is used, do not install in hazardous atmosphere where ignition temperature is less than 180° C. See nameplate/retainer for service. **NOTE:** These solenoids have an internal non-resettable thermal fuse to limit solenoid temperature in the event that extraordinary conditions occur which could cause excessive temperatures. These conditions include high input voltage, a jammed core, excessive ambient temperature or shorted solenoid, etc. This unique feature is a standard feature only in solenoids with black explosionproof/dust-ignitionproof enclosures (types 7&9).

IMPORTANT: To protect the solenoid valve or operator, install a strainer or filter, suitable for the service involved in the inlet side as close to the valve or operator as possible. Clean periodically depending on service condition & See ASCO Series 8600, 8601, and 8602 for strainers.

Temperature Limitations

For maximum valve ambient temperatures, refer to chart. The temperature limitations listed, only indicate maximum application temperatures for field wiring rated at 90°C. Check catalog number prefix and watt rating on nameplate to determine maximum ambient temperature. See valve installation and maintenance instructions for maximum fluid temperature. **NOTE:** For steam service, refer to Wiring section, Junction Box for temperature rating of supply wires.

Temperature Limitations For Series 8016G Solenoids for use Valves Rated at 6.1, 8.1,9.1,10.6 or 11.1 Watts			
Watts Rating	Catalog Number Coil prefix	Class of Insulation	Maximum ambient Temp. °F
6.1, 8.1, 9.1, & 11.1	None, FB, KF, KP, SF, SP, SC, & SD	F	125
6.1, 8.1, 9.1, & 11.1	HB, HT, KB, KH, SS, ST, SU, & ST	H	140
10.6	None, KF, SF, & SC	F	104
10.6	HT, KH, SU, & ST	H	104

Minimum ambient temperature -40° F (-40° C); Positioning

Positioning

This solenoid is designed to perform properly when mounted in any position. However, for optimum life and performance, the solenoid should be mounted vertically and upright to reduce the possibility of foreign matter accumulating in the solenoid base sub-assembly area.

Wiring

Wiring must comply with local codes and the National Electrical Code. All solenoids supplied with lead wires are provided with a grounding wire which is green or green with yellow stripes and a 1/2" conduit connection. To facilitate wiring, the solenoid may be rotated 360°. For the watertight and explosionproof solenoid, electrical fittings must be approved for use in the approved hazardous locations.

Additional Wiring Instructions For Optional Features:

- **Open-Frame solenoid with 1/4" spade terminals**
For solenoids supplied with screw terminal connections use #12-18 AWG stranded copper wire rated at 90°C or greater. Torque terminal block screws to 10 ± 2 in-lbs (1.0 + 1.2 Nm). A tapped hole is provided in the solenoid for grounding, use a #Y10-32 machine screw. Torque grounding screw to 15 -20

in-lbs (1,7 - 2,3 Nm). On solenoids with screw terminals, the socket head screw holding the terminal block to the solenoid is the grounding screw. Torque the screw to 15 - 20 in-lbs (1,7 - 2,3 Nm). with a 5/32" hex key wrench.

• Junction Box

The junction box is used with spade or screw terminal solenoids only and is provided with a grounding screw and a 1/2" conduit connection. Connect #12-18AWG standard copper wire only to the screw terminals. Within the junction box use field wire that is rated 90°C or greater for connections. For steam service use 105°C rated wire up to 50 psi or use 125°C rated wire above 50 psi. After electrical hookup, replace cover gasket, cover, and screws. Tighten screws evenly in a crisscross manner.

• DIN Plug Connector Kit No. KC236-034

1. The open—frame solenoid is provided with DIN terminals to accommodate the DIN plug connector kit.
2. Remove center screw from plug connector. Using a small screwdriver, pry terminal block from connector cover.
3. Use #12-18 AWG stranded copper wire rated at 90°C or greater for connections. Strip wire leads back approximately 1/4" for installation in socket terminals. The use of wire-end sleeves is also recommended for these socket terminals. Maximum length of wire-end sleeves to be approximately 1/4". Tinning of the ends of the lead wires is not recommended.
4. Thread wire through gland nut, gland gasket, washer, and connector cover.

NOTE: Connector cover may be rotated in 90° increments from position shown for alternate positioning of cable entry.

5. Check DIN connector terminal block for electrical markings. Then make electrical hookup to terminal block according to markings on it. Snap terminal block into connector cover and install center screw.
6. Position connector gasket on solenoid and install plug connector. Torque center screw to 5 ± 1 in-lbs ($0,6 \pm 1,1$ Nm).

NOTE: Alternating current (AC) and direct current (DC) solenoids are built differently. To convert from one to the other, it may be necessary to change the complete solenoid including the core and solenoid base sub-assembly, not just the solenoid. Consult ASCO.

Installation of Solenoid

Solenoids may be assembled as a complete unit. Tightening is accomplished by means of a hex flange at the base of the solenoid. The 3/4" bonnet construction (Figure 1) must be disassembled for installation and installed with a special wrench adapter.

Installation of Panel Mounted Solenoid (See Figure 3)

Disassemble solenoid following instruction under Solenoid Replacement then proceed

3/4" Valve Bonnet Construction

1. Install retainer(convex side to solenoid) in 1.312 diameter mounting hole in customer panel.
2. Then position spring washer over plugnut/core tube sub-assembly.
3. Install plugnut/core tube sub-assembly through retainer in customer panel. Then replace solenoid, nameplate/retainer and red cap.

15/16" Valve Bonnet Construction

1. Install solenoid base sub-assembly through 0.69 diameter mounting hole in customer panel.
2. Position spring washer on opposite side of panel over solenoid base sub-assembly then replace.

Solenoid Temperature

Standard solenoids are designed for continuous duty service. When the solenoid is energized for a long period, the solenoid becomes hot and can be touched by hand only for an instant. This is a safe operating temperature.

MAINTENANCE

WARNING: To prevent the possibility of personal injury or property damage, turn off electrical power, depressurize solenoid operator and/or valve, and vent fluid to a safe area before servicing.

Cleaning

All solenoid operators and valves should be cleaned periodically. The time between cleaning will vary depending on medium and service conditions. In general, if the voltage to the solenoid is correct, sluggish valve operation, excessive noise or leakage will indicate that cleaning is required. Clean strainer or filter when cleaning the valve,

Preventive Maintenance

- Keep the medium flowing through the solenoid operator or valve as free from dirt and foreign material as possible.
- While in service, the solenoid operator or valve should be operated at least once a month to insure proper opening and closing.
- Depending on the medium and service conditions, periodic inspection of internal valve parts for damage or excessive wear is recommended. Thoroughly clean all parts. Replace any worn or damaged parts.

Causes of Improper Operation

- **Faulty Control Circuit:** Check the electrical system by energizing the solenoid. A metallic click signifies that the solenoid is operating. Absence of the click indicates loss of power supply. Check for loose or blown fuses, open-circuited or grounded solenoid, broken lead wires or splice connections.

- **Burned-Out Solenoid:** Check for open-circuited solenoid. Replace if necessary. Check supply voltage; it must be the same as specified on nameplate/retainer and marked on the solenoid. Check ambient temperature and check that the core is not jammed.

- **Low Voltage:** Check voltage across the solenoid leads. Voltage must be at least 85% of rated voltage.

Solenoid Replacement

1. On solenoids with lead wires disconnect conduit, coil leads, and grounding wire.

NOTE: Any optional parts attached to the old solenoid must be reinstalled on the new solenoid.

2. Disassemble solenoids with optional features as follows:

• Spade or Screw Terminals

Remove terminal connections, grounding screw, grounding wire, and terminal block (screw terminal type only).

NOTE: For screw terminals, the socket head screw holding the terminal block serves as a grounding screw.

• Junction Box

Remove conduit and socket head screw (use 5/32" hex key wrench) from center of junction box. Disconnect junction box from solenoid.

• DIN Plug Connector

Remove center screw from DIN plug connector. Disconnect DIN plug connector from adapter. Remove socket head screw (use 5/32" hex key wrench), DIN terminal adapter, and gasket from solenoid.

3. Snap off red cap from top of solenoid base sub-assembly.
4. Push down on solenoid. Then using a suitable screwdriver, insert blade in slot provided between solenoid and nameplate/retainer. Pry up slightly and push to remove. Then remove solenoid from solenoid base sub-assembly.
5. Reassemble using exploded views for parts identification and placement

Disassembly and Reassembly of Solenoids

1. Remove solenoid, see Solenoid Replacement.
2. Remove finger washer or spring washer from solenoid base sub-assembly.
3. Unscrew solenoid base sub-assembly.

NOTE: Some solenoid constructions have a plugnut/core tube sub-assembly, bonnet gasket and bonnet in place of the solenoid base sub-assembly. To remove bonnet use special wrench adapter supplied in ASCO Rebuild Kit. For wrench adapter only, order ASCO Wrench Kit No.K218 - 948.

4. The core is now accessible for cleaning or replacement.
5. If the solenoid is part of a valve, refer to basic valve installation and maintenance instructions for further disassembly.
6. Reassemble using exploded views for identification and placement of parts.

ORDERING INFORMATION FOR ASCO SOLENOIDS

When Ordering Solenoids for ASCO Solenoid Operators or Valves, order the number stamped on the solenoid. Also specify voltage and frequency.

Torque Chart

Part Name	Torque Value in inch-Pounds	Torque Value in Newton-Meters
solenoid base sub-assembly	175 ± 25	19.8 ± 2.8
valve bonnet (3/4" bonnet constructions)	90 ± 10	10.2 ± 1.1
bonnet screw (3/8" or 1/2" NPT pipe size)	25	2.8
bonnet screw (3/4" NPT pipe size)	40	4.5

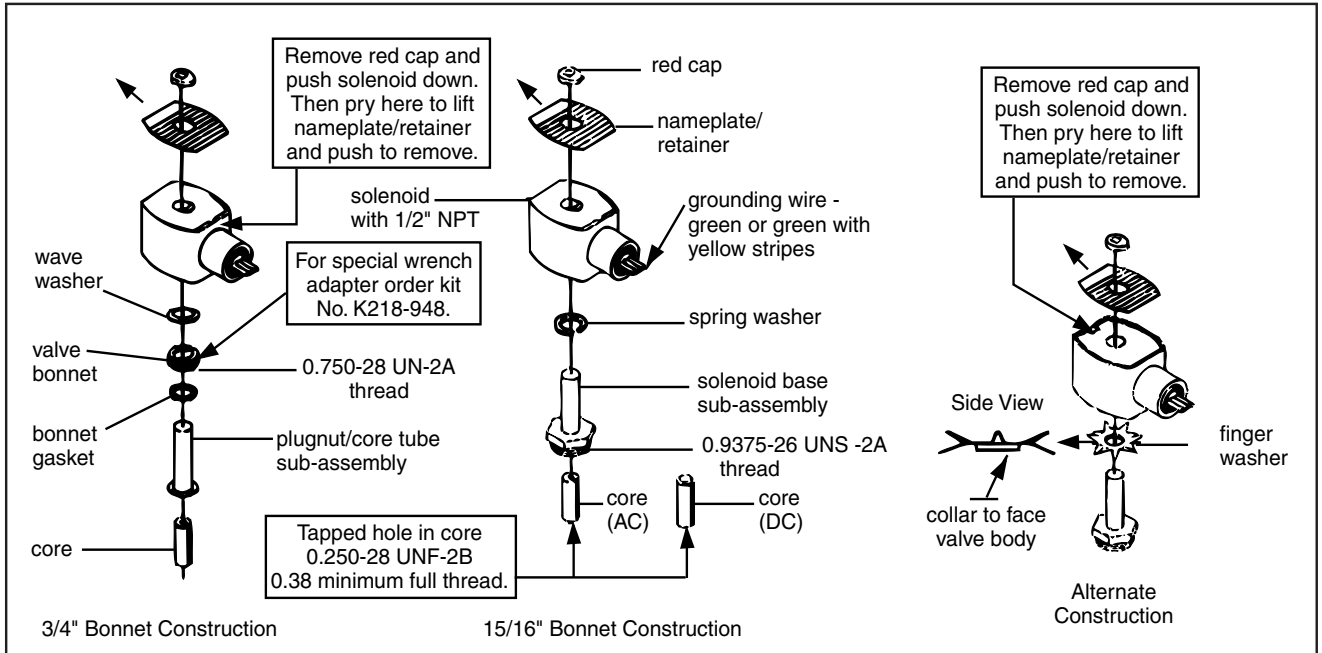

Figure 1. Series 8016G solenoids

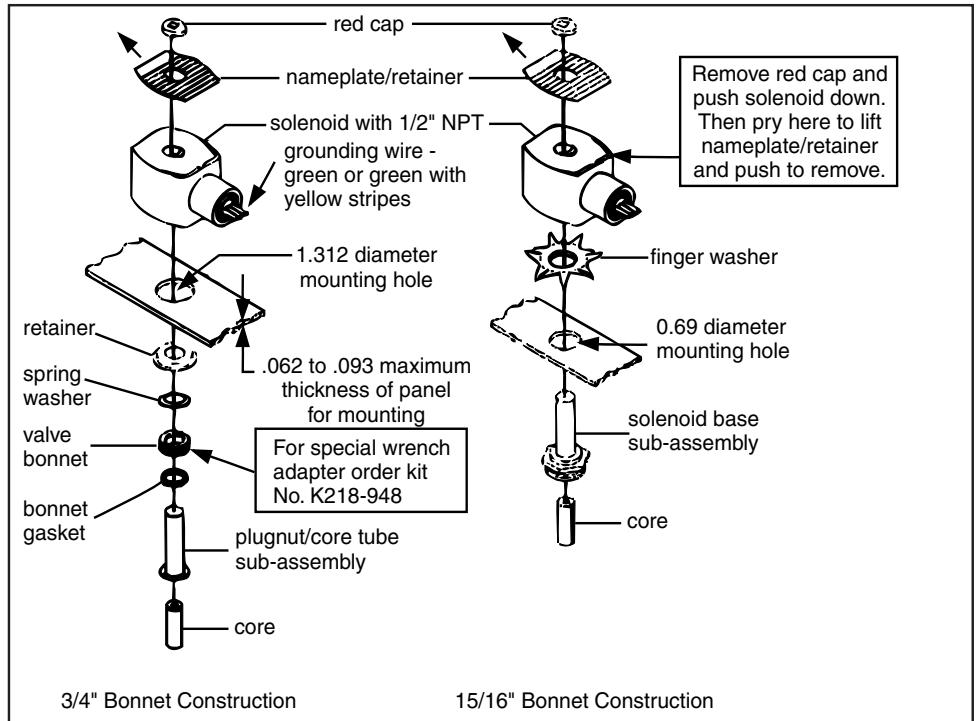
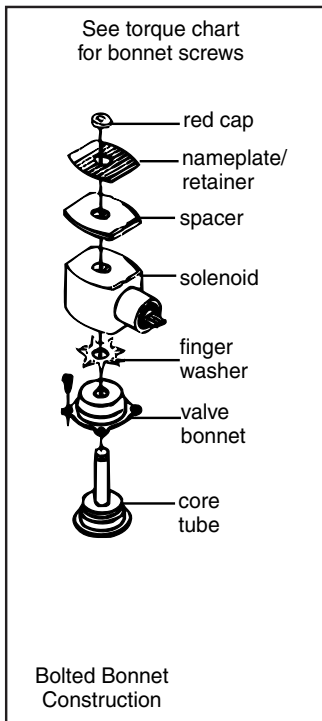

Figure 2. Series 8016G solenoid

Figure 3. Series 8016G panel mounted solenoids

Torque Chart

Part Name	Torque Value in inch-Pounds	Torque Value in Newton-Meters
terminal block screws	10 ± 2	1,1 ± 0,2
socket head screw	15 - 20	1,7 - 2,3
center screw	5 ± 1	0,6 ± 0,1

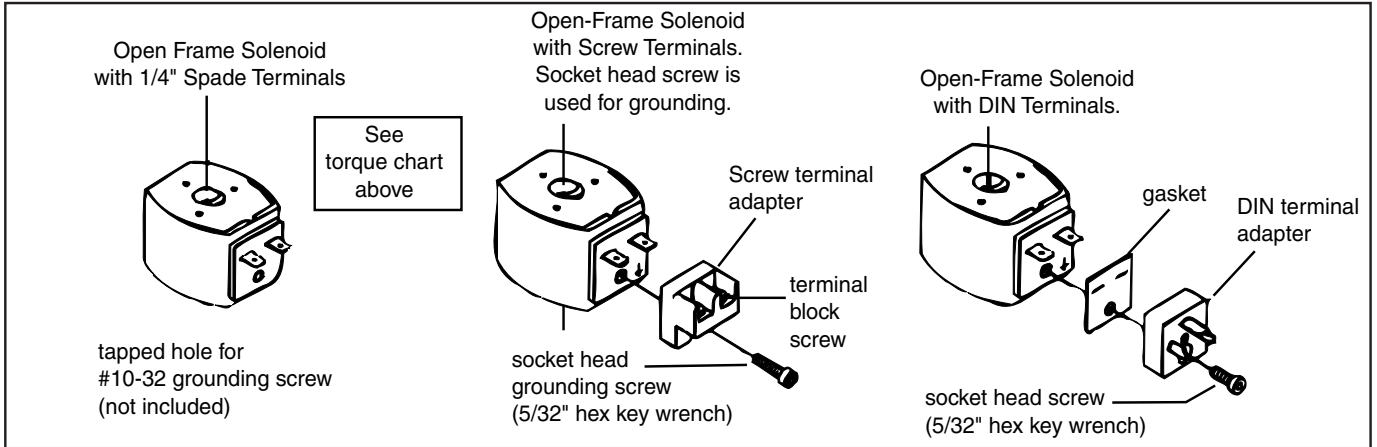

Figure 4. Open - frame solenoids

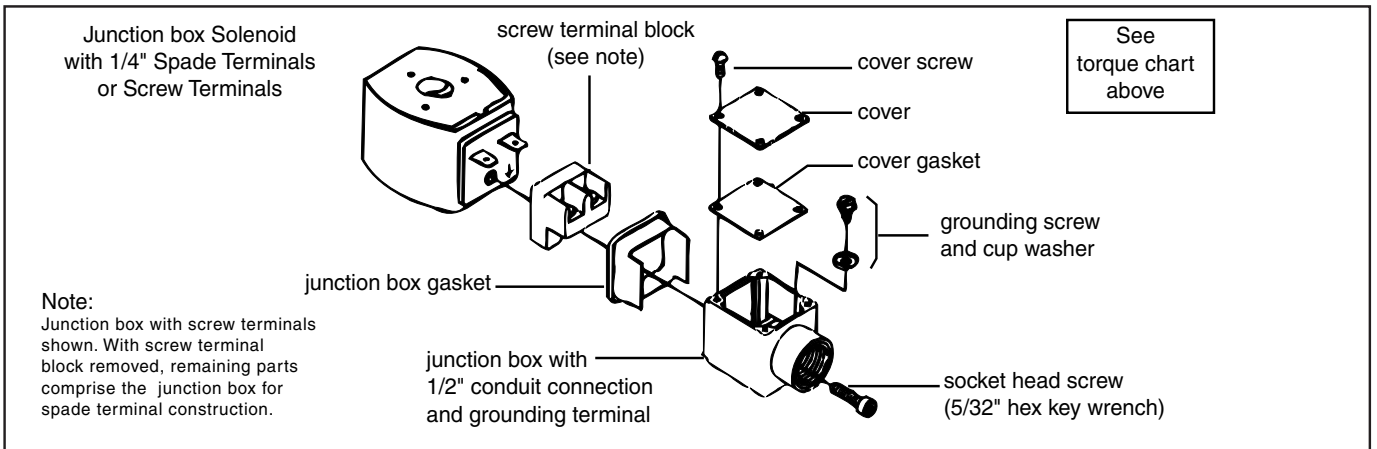
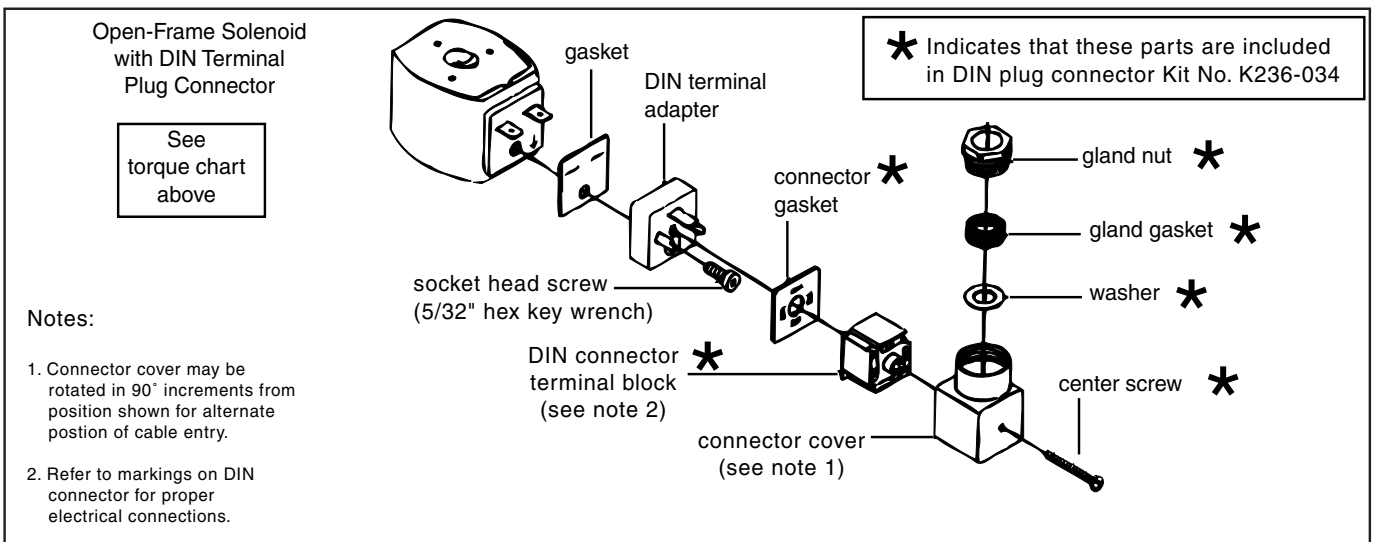

Figure 5. Open - frame solenoids





— MODEL — **CV**
Flow Control



DESCRIPTION

The Cla-Val Model CV Flow Control is a simply-designed, spring-loaded check valve. Rate of flow is full flow in one direction and restricted in other direction. Flow is adjustable in the restricted direction. It is intended for use in conjunction with a pilot control system on a Cla-Val Automatic Control Valve.

OPERATION

The CV Flow Control permits full flow from port A to B, and restricted flow in the reverse direction. Flow from port A to B lifts the disc from seat, permitting full flow. Flow in the reverse direction seats the disc, causing fluid to pass through the clearance between the stem and the disc. This clearance can be increased, thereby increasing the restricted flow, by screwing the stem out, or counter-clockwise. Turning the stem in, or clockwise reduces the clearance between the stem and the disc, thereby reducing the restricted flow.

INSTALLATION

Install the CV Flow Control as shown in the valve schematic. All connections must be tight to prevent leakage.

DISASSEMBLY

Follow the sequence of the item numbers assigned to the parts in the cross sectional illustration for recommended order of disassembly.

Use a scriber, or similar sharp-pointed tool to remove O-ring from the stem.

INSPECTION

Inspect all threads for damage or evidence of cross-threading. Check mating surface of seat and valve disc for excessive scoring or embedded foreign particles. Check spring for visible distortion, cracks and breaks. Inspect all parts for damage, corrosion and cleanliness.

CLEANING

After disassembly and inspection, cleaning of the parts can begin. Water service usually will produce mineral or lime deposits on metal parts in contact with water. These deposits can be cleaned by dipping the parts in a 5-percent muriatic acid solution just long enough for deposits to dissolve. This will remove most of the common types of deposits. **Caution: use extreme care when handling acid.** If the deposit is not removed by acid, then a fine grit (400) wet or dry sandpaper can be used with water. Rinse parts in water before handling. An appropriate solvent can clean parts used in fueling service. Dry with compressed air or a clean, lint-free cloth. Protect from damage and dust until reassembled.

REPAIR AND REPLACEMENT

Minor nicks and scratches may be polished out using a fine grade of emery or crocus cloth; replace parts if scratches cannot be removed.

Replace O-ring packing and gasket each time CV Flow Control is overhauled.

Replace all parts which are defective. Replace any parts which create the slightest doubt that they will not afford completely satisfactory operation. Use Inspection steps as a guide.

REASSEMBLY

Reassembly is the reverse of disassembly; no special tools are required.

TEST PROCEDURE

No testing of the flow Control is required prior to reassembly to the pilot control system on Cla-Val Main Valve.



CV

3/8" Flow Control

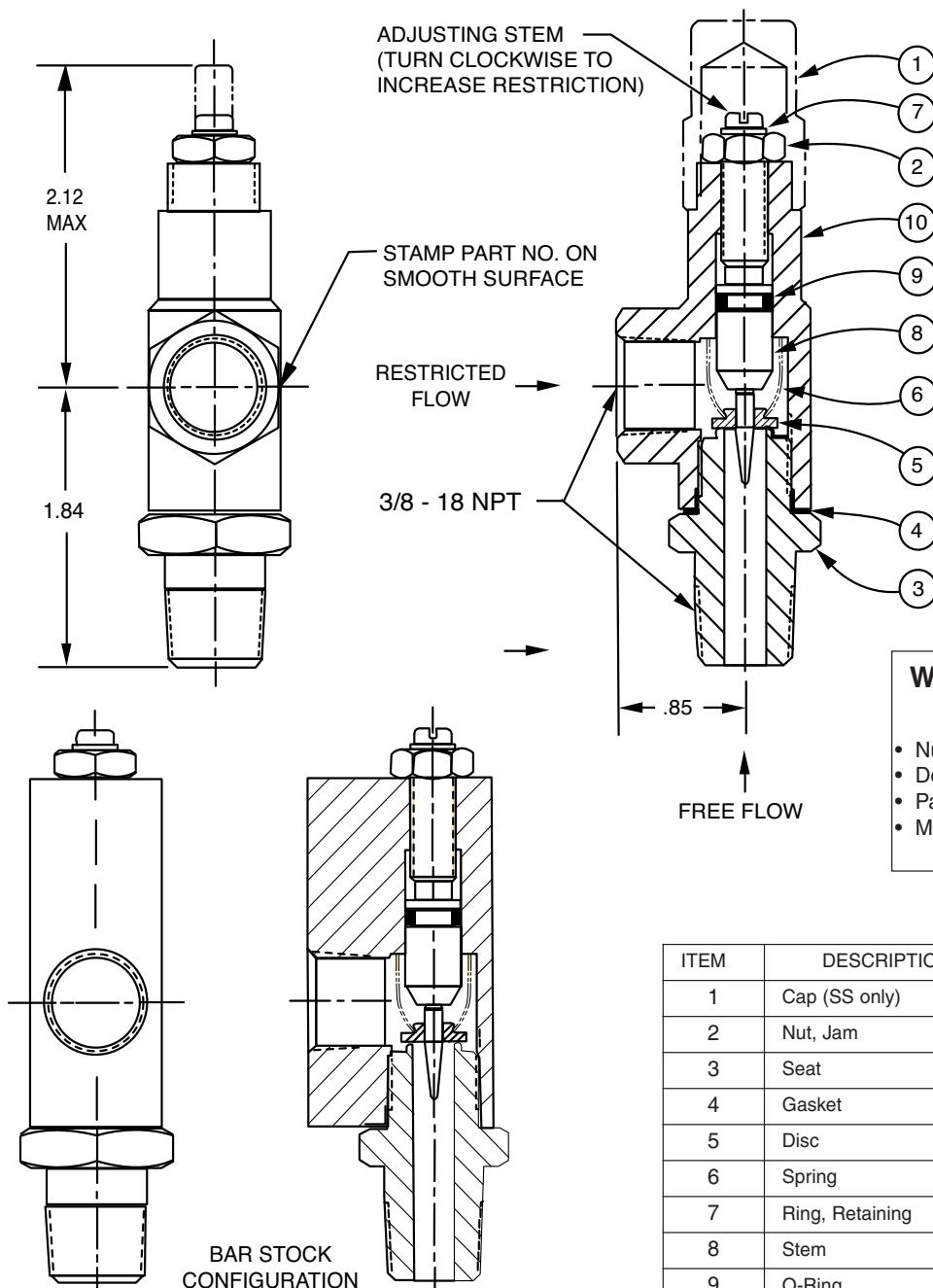

ITEM	DESCRIPTION	QTY
1	Cap (SS only)	1
2	Nut, Jam	1
3	Seat	1
4	Gasket	1
5	Disc	1
6	Spring	1
7	Ring, Retaining	1
8	Stem	1
9	O-Ring	1
10	Housing	1



NEWPORT BEACH, CALIFORNIA

CATALOG NO.
CSC

DRAWING NO.
92667

REV.
A

TYPE OF VALVE AND MAIN FEATURES

CSC SWING CHECK VALVE

DESIGN		
DRAWN	CH	11-5-76
CHK'D	MF	11-8-76
APVD	JAZ	11-9-76

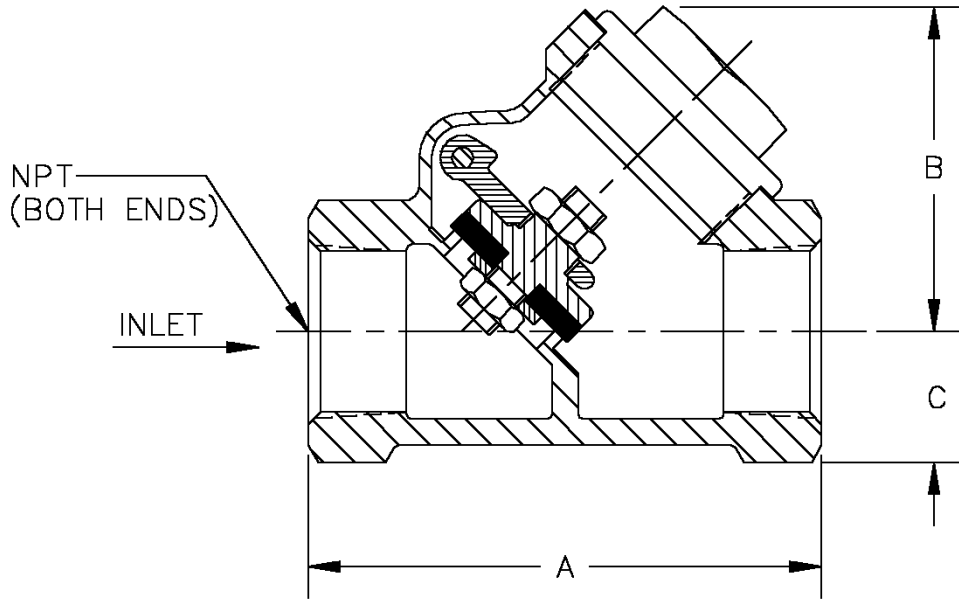

PIPE SIZE NPT	A	B	C
.25 (1/4)	2.13	1.63	.50
.38 (3/8)	2.13	1.63	.50
.50 (1/2)	2.44	1.69	.63
.75 (3/4)	2.94	1.88	.75
1.00 (1)	3.19	2.09	.94

CAD REVISION RECORD - DO NOT REVISE MANUALLY

LTR	DESCRIPTION	BY	DATE
A	REDRAWN ON CAD (ECO 14229)	EK	11-15-93

THIS DRAWING IS THE PROPERTY OF CLA-VAL CO. AND SAME AND COPIES MADE THEREOF, IF ANY, SHALL BE RETURNED TO IT UPON DEMAND. DELIVERY AND DISCLOSURE HEREOF ARE SOLELY UPON CONDITION THAT THE SAME SHALL NOT BE USED, COPIED OR REPRODUCED, NOR SHALL THE SUBJECT HEREOF BE DISCLOSED IN ANY MANNER TO ANYONE FOR ANY PURPOSE, EXCEPT AS HEREIN AUTHORIZED, WITHOUT PRIOR WRITTEN APPROVAL OF CLA-VAL CO. THIS DRAWING IS SUBMITTED CONFIDENTIALLY AND MAY NOT BE USED IN THE MANUFACTURE OF ANY MATERIAL OR PRODUCT OTHER THAN SUCH MATERIALS AND PRODUCTS FURNISHED TO CLA-VAL CO. WHETHER OR NOT THE EQUIPMENT OR INFORMATION SHOWN HEREON IS PATENTED OR OTHERWISE PROTECTED, FULL TITLE AND COPYRIGHTS, IF ANY, IN AND TO THIS DRAWING AND/OR INFORMATION DELIVERED OR SUBMITTED ARE FULLY RESERVED CLA-VAL CO.®



—MODEL— **CDC-1**

Check Valve (Sizes 3/8" and 1/2")



- NSF 61 Approved
- Meets low lead requirements
- Soft Seat for Bubble Tight Shutoff, Spring Loaded for Fast Seating Action
- Compact Design
- Low Cracking Pressure 1/2 psi
- Flow Profile Designed to Minimize Head Loss
- Perfect Seating both at High and Low Pressure, Wide Temperature Range: +10° to 210°F
- Polyetherimide Disc to ensure the Best Resistance for Corrosion and Abrasion
- Patented Disc Guide to Prevent Any Side Loading

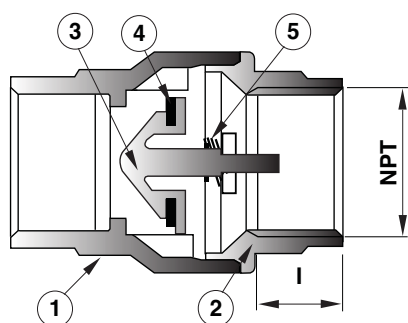

Full Open Operation

Item	Description	Material
1	Body	Brass
2	End Connection	Brass
3	Disc	Polyetherimide
4	Seat	NBR
5	Spring	Stainless Steel

Available only in replacement assembly.

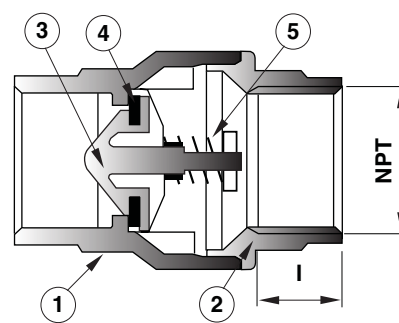

Tight Closing Operation

Dimensions

Size (NPT)	Stock Number	A	B	C	I	C _v	psi	Wt.
3/8"	9834501A	1.73	0.79	1.06	0.40	4.55	400	0.37
1/2"	9834502J	2.32	0.98	1.35	0.53	6.00	400	0.32

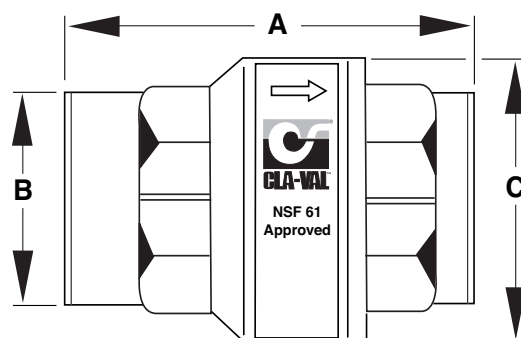



NEWPORT BEACH, CALIFORNIA

CATALOG NO. 60 SERIES

DRAWING NO. 69548

REV. E

TYPE OF VALVE AND MAIN FEATURES

SUGGESTED WIRING DIAGRAM FOR 60 SERIES PUMP CONTROL VALVE SHOWN WITH PUMP IN "OFF" POSITION

DESIGN		
DRAWN	B.F.	10-20-67
CHK'D	J.M.	10-21-67
APVD	HWE	10-21-67

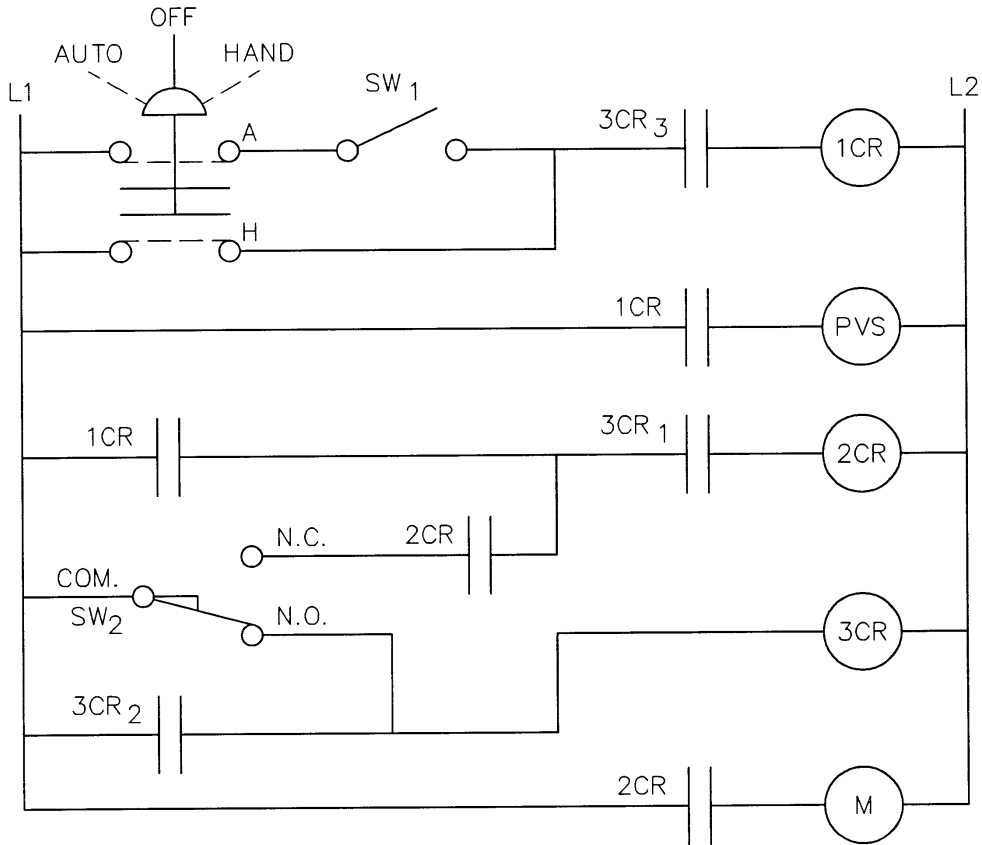

AUTO - OFF - HAND = SELECTOR SWITCH	
1CR	= RELAY, DPST NORMALLY OPEN
2CR	= RELAY, DPST NORMALLY OPEN
3CR	= RELAY, TPST NORMALLY OPEN
SW ₁	= SWITCH, REMOTE START, AUTOMATIC
SW ₂	= SWITCH, SPDT, VALVE LIMIT SWITCH
PVS	= PILOT VALVE SOLENOID
M	= PUMP MOTOR STARTER

NOTE: SW₂ AND PVS SUPPLIED BY CLA-VAL CO. ALL OTHER ELECTRICAL ITEMS SUPPLIED BY CUSTOMER. SW₂ IS INCLUDED IN THE X105L SWITCH ASSY WHICH IS MOUNTED ON THE PUMP CONTROL VALVE COVER.

CAD REVISION RECORD - DO NOT REVISE MANUALLY	
DESCRIPTION	DATE
A-D SEE REVISION FILE (ECO 19510)	
E REVISED AND REDRAWN ON CAD (ECO 19510)	P.M.C. 8-13-2003
LTR	BY

THIS DRAWING IS THE PROPERTY OF CLA-VAL CO. AND SAME AND COPIES MADE THEREOF, IF ANY, SHALL BE RETURNED TO IT UPON DEMAND. DELIVERY AND DISCLOSURE HEREOF ARE SOLELY UPON CONDITION THAT THE SAME SHALL NOT BE USED, COPIED OR REPRODUCED, NOR SHALL THE SUBJECT HEREOF BE DISCLOSED IN ANY MANNER TO ANYONE FOR ANY PURPOSE, EXCEPT AS HEREIN AUTHORIZED, WITHOUT PRIOR WRITTEN APPROVAL OF CLA-VAL CO. THIS DRAWING IS SUBMITTED CONFIDENTIALLY AND MAY NOT BE USED IN THE MANUFACTURE OF ANY MATERIAL OR PRODUCT OTHER THAN SUCH MATERIALS AND PRODUCTS FURNISHED TO CLA-VAL CO. WHETHER OR NOT THE EQUIPMENT OR INFORMATION SHOWN HEREON IS PATENTED OR OTHERWISE PROTECTED, FULL TITLE AND COPYRIGHTS, IF ANY, IN AND TO THIS DRAWING AND/OR INFORMATION DELIVERED OR SUBMITTED ARE FULLY RESERVED CLA-VAL CO.

CLA-VAL CO.	NEWPORT BEACH, CALIFORNIA	CATALOG NO. 60 SERIES	DRAWING NO. 69548	REV E
	SUGGESTED WIRING DIAGRAM FOR 60 SERIES PUMP CONTROL VALVE SHOWN WITH PUMP IN "OFF" POSITION			

SUGGESTED WIRING DIAGRAM FOR 60 SERIES PUMP CONTROL VALVE SHOWN WITH PUMP IN "OFF" POSITION

DESIGN			
DRAWN	B.F.	10-20-67	
CHK'D	J.M.	10-21-67	
APVD	HWE	10-21-67	

WIRING DIAGRAM EXPLANATION

THIS SUGGESTED WIRING DIAGRAM PROVIDES ELECTRICAL INTERLOCK TO PREVENT SURGES ON START UP & SHUT DOWN OF ELECTRIC MOTOR-DRIVEN PUMPS. IT IS SUITABLE FOR MOST APPLICATIONS OF CLA-VAL 60 & 61 SERIES PUMP CONTROL VALVES.

FOR EXPLANATION OF HYDRAULIC VALVE OPERATION AND PUMP STARTING-STOPPING SURGE PROTECTION SEQUENCE, SEE CATALOG DATA SHEET FOR 60 SERIES BOOSTER PUMP CONTROL VALVES (e.g. -E-60-11, ETC) OR 61 SERIES DEEP WELL PUMP CONTROL VALVES (e.g. -E-61-02, ETC).

PUMP OFF

THE PUMP CONTROL VALVE WILL BE IN ITS HYDRAULICALLY NORMALLY OPEN (FOR 61 SERIES VALVES) OR NORMALLY CLOSED (FOR 60 SERIES VALVES) POSITION. SW2 IS MOUNTED ON THE PUMP CONTROL VALVE AND IS IN THE OPEN POSITION (N.O.) WHEN THE PUMP IS OFF. 3CR RELAY IS ENERGIZED AND ALL OF IT'S CONTACTS ARE CLOSED.

AUTO-OFF-HAND SWITCH ALLOWS SELECTION OF THREE MODES. AUTO OR AUTOMATIC MODE SIGNALS PUMP ON AND OFF UNDER COMMAND OF REMOTE SWITCH SW1. THIS COULD BE ANY REMOTE SWITCH FROM A SIMPLE PRESSURE SWITCH TO A COMPLEX COMPUTER SYSTEM SWITCH. HAND MODE ALLOWS OVERRIDING THE AUTO MODE FOR THOSE TIMES WHEN IT IS NECESSARY TO MANUALLY (AT THE PANEL) SIGNAL THE PUMP TO START (HAND) AND STOP (OFF).

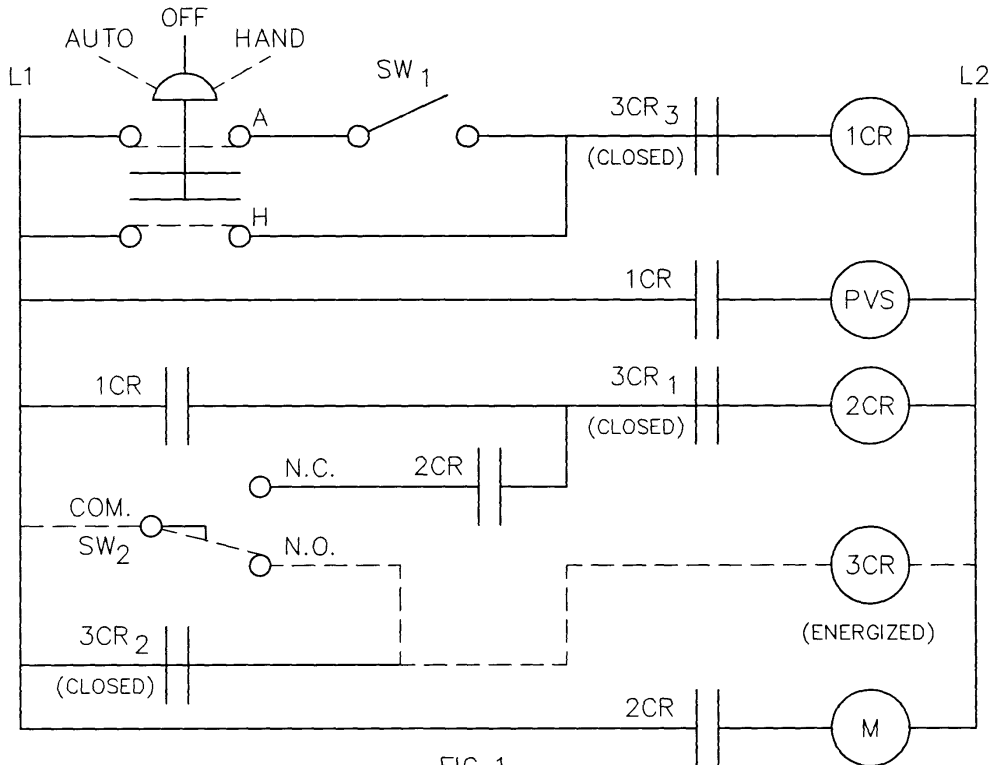

FIG 1

CAD REVISION RECORD - DO NOT REVISE MANUALLY
BY _____ DATE _____
DESCRIPTION
SEE SHEET 1

THIS DRAWING IS THE PROPERTY OF CLA-VAL CO. AND SAME AND COPIES MADE THEREOF, IF ANY, SHALL BE RETURNED TO IT UPON DEMAND. DELIVERY AND DISCLOSURE HEREOF ARE SOLELY UPON CONDITION THAT THE SAME SHALL NOT BE USED, COPIED OR REPRODUCED, NOR SHALL THE SUBJECT HEREOF BE DISCLOSED IN ANY MANNER TO ANYONE FOR ANY PURPOSE, EXCEPT AS HEREIN AUTHORIZED, WITHOUT PRIOR WRITTEN APPROVAL OF CLA-VAL CO. THIS DRAWING IS SUBMITTED CONFIDENTIALLY AND MAY NOT BE USED IN THE MANUFACTURE OF ANY MATERIAL OR PRODUCT OTHER THAN SUCH MATERIALS AND PRODUCTS FURNISHED TO CLA-VAL CO. WHETHER OR NOT THE EQUIPMENT OR INFORMATION SHOWN HEREON IS PATENTED OR OTHERWISE PROTECTED, FULL TITLE AND COPYRIGHTS, IF ANY, IN AND TO THIS DRAWING AND/OR INFORMATION DELIVERED OR SUBMITTED ARE FULLY RESERVED. CLA-VAL CO.



NEWPORT BEACH, CALIFORNIA

CATALOG NO.

60 SERIES

DRAWING NO.

69548

REV

E

SUGGESTED WIRING DIAGRAM FOR 60 SERIES PUMP CONTROL VALVE SHOWN WITH PUMP IN "OFF" POSITION

DESIGN

DRAWN

B.F.

10-20-67

CHK'D

J.M.

10-21-67

APVD

HWE

10-21-67

PUMP SIGNALLED TO GO "ON"

USING "AUTO" MODE

- STEP 1: SELECTOR SWITCH IS TURNED TO AUTO POSITION. ELECTRICITY FROM L1 GOES THROUGH THE SWITCH TO TERMINAL A AND TO SW1. WHEN A REMOTE PRESSURE SWITCH OR OTHER ELECTRICAL SWITCH CLOSSES SW1, ELECTRICITY GOES THROUGH 3CR3 (ALREADY CLOSED), AND ENERGIZES 1CR COIL AND CLOSES ITS CONTACTS.
- STEP 2: WHEN 1CR CONTACTS CLOSE, PVS IS ENERGIZED AND SHIFTS PORTS CAUSING THE PUMP CONTROL VALVE TO BEGIN MOVING. AT THE SAME TIME 1CR ENERGIZED THE PVS COIL, ITS SECOND SET OF CONTACTS CLOSED WHICH ALLOWED ELECTRICITY TO GO FROM L1 THROUGH 1CR AND 3CR1 TO ENERGIZE RELAY 2CR.
- STEP 3: WHEN 2CR RELAY IS ENERGIZED, ITS FIRST SET OF POINTS CLOSE AND COMPLETE THE CIRCUIT FROM L1 THROUGH THE N.C. TERMINAL OF SW1 AND 3CR1. AT THE SAME TIME, ITS SECOND SET OF POINTS CLOSE, WHICH ALLOWS ELECTRICITY FROM L1 THROUGH 2CR TO THE PUMP MOTOR STARTER. THIS STARTS THE PUMP AND COMPLETES THE CIRCUIT TO L2.

THE PUMP IS NOW ON

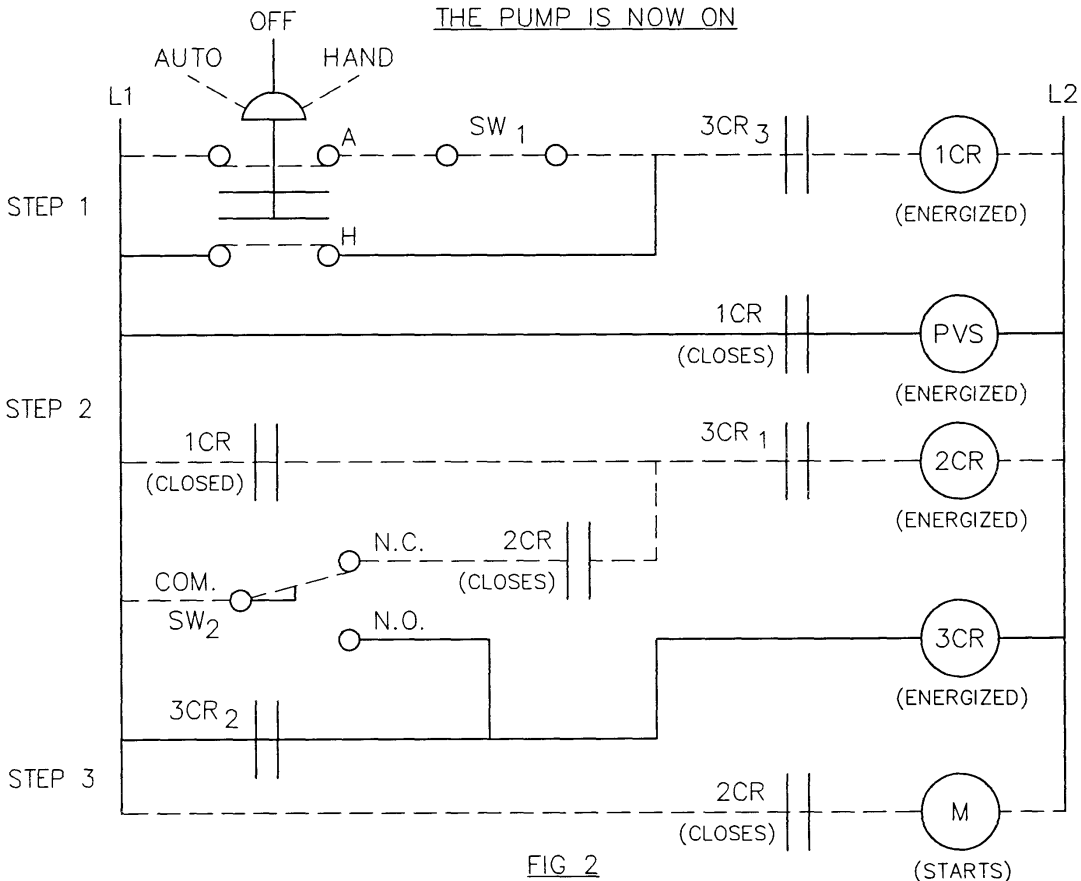

FIG 2

CAD REVISION RECORD - DO NOT REVISE MANUALLY

DATE

DESCRIPTION

BY
SEE SHEET 1

LTR



CLA-VAL CO.

NEWPORT BEACH, CALIFORNIA

CATALOG NO.

60 SERIES

DRAWING NO.

69548

REV

E

SUGGESTED WIRING DIAGRAM FOR 60 SERIES PUMP CONTROL VALVE SHOWN WITH PUMP IN "OFF" POSITION

DESIGN		
DRAWN	B.F.	10-20-67
CHK'D	J.M.	10-21-67
APVD	HWE	10-21-67

PUMP SIGNALLED TO GO "OFF"

USING "AUTO" MODE

- STEP 1: REMOTE SWITCH SW1 OPENS AND DE-ENERGIZES THE COIL OF 1CR RELAY AND ALL 1CR CONTACTS.
- STEP 2: THE FIRST SET OF CONTACTS OF 1CR OPEN AND STOP THE ELECTRICITY TO THE COIL OF PVS. PVS SHIFTS PORTS CAUSING THE PUMP CONTROL VALVE TO BEGIN MOVING. AT THE SAME TIME THE SECOND SET OF CONTACTS TO 2CR COIL OPEN. 2CR IS HELD ENERGIZED BY CONNECTION TO L1 THROUGH SW2.
- STEP 3: WHEN THE PUMP CONTROL VALVE HYDRAULICALLY REACHES ITS DE-ENERGIZED POSITION (SEE PUMP OFF STEP, ABOVE) IT MOVES SW2 FROM N.C. CONTACT TO N.O. CONTACT AND STOPS ELECTRICITY TO 2CR COIL. 2CR DE-ENERGIZES AND OPENS ITS CONTACTS, WHICH IN TURN DE-ENERGIZES PUMP MOTOR STARTER AND SHUTS PUMP OFF.

THE PUMP IS NOW OFF

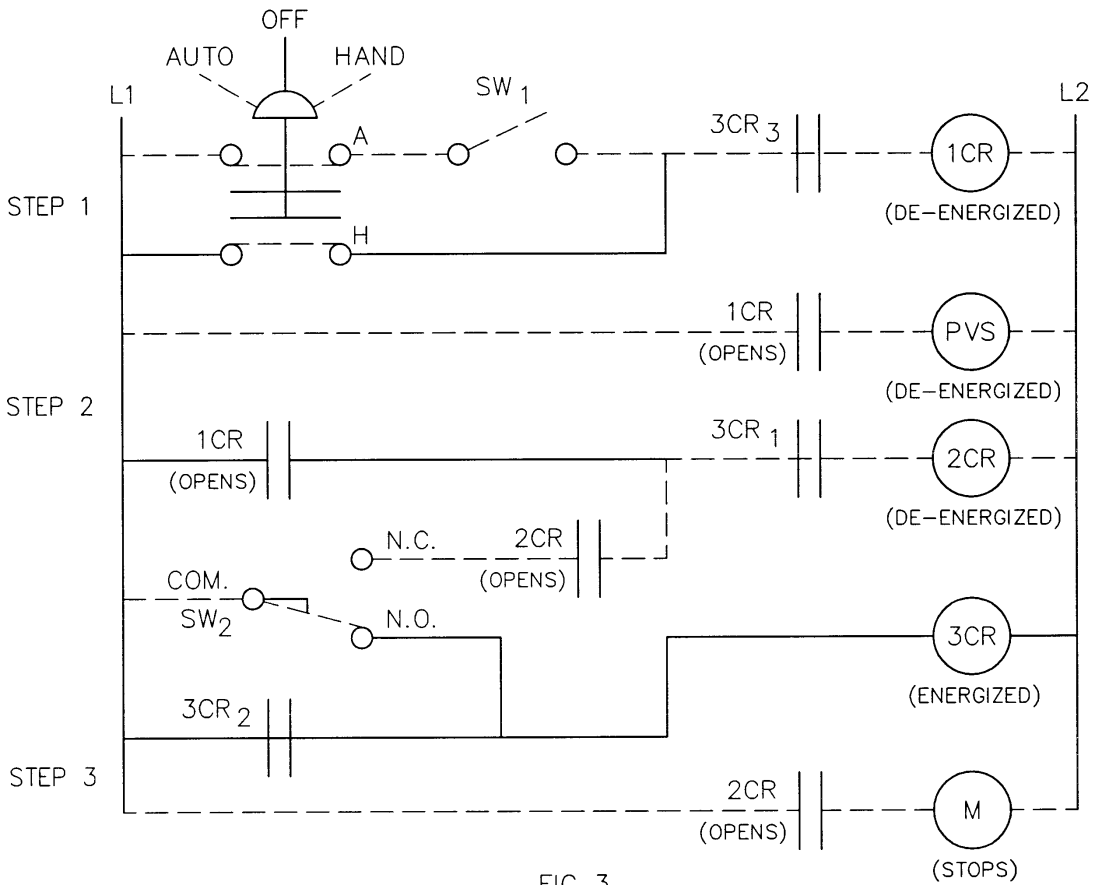

FIG 3

CAD REVISION RECORD - DO NOT REVISE MANUALLY	DATE
	BY
DESCRIPTION	
SEE SHEET 1	
LTR	

THIS DRAWING IS THE PROPERTY OF CLA-VAL CO. AND SAME AND COPIES MADE THEREOF, IF ANY, SHALL BE RETURNED TO IT UPON DEMAND. DELIVERY AND DISCLOSURE HEREOF ARE SOLELY UPON CONDITION THAT THE SAME SHALL NOT BE USED, COPIED OR REPRODUCED, NOR SHALL THE SUBJECT HEREOF BE DISCLOSED IN ANY MANNER TO ANYONE FOR ANY PURPOSE, EXCEPT AS HEREIN AUTHORIZED, WITHOUT PRIOR WRITTEN APPROVAL OF CLA-VAL CO. THIS DRAWING IS SUBMITTED CONFIDENTIALLY AND MAY NOT BE USED IN THE MANUFACTURE OF ANY MATERIAL OR PRODUCT OTHER THAN SUCH MATERIALS AND PRODUCTS FURNISHED TO CLA-VAL CO. WHETHER OR NOT THE EQUIPMENT OR INFORMATION SHOWN HEREON IS PATENTED OR OTHERWISE PROTECTED, FULL TITLE AND COPYRIGHTS, IF ANY, IN AND TO THIS DRAWING AND/OR INFORMATION DELIVERED OR SUBMITTED ARE FULLY RESERVED CLA-VAL CO.



CLA-VAL CO.

NEWPORT BEACH, CALIFORNIA

CATALOG NO.

60 SERIES

DRAWING NO.

69548

REV

E

SUGGESTED WIRING DIAGRAM FOR 60 SERIES PUMP CONTROL VALVE SHOWN WITH PUMP IN "OFF" POSITION

DESIGN		
DRAWN	B.F.	10-20-67
CHK'D	J.M.	10-21-67
APV'D	HWE	10-21-67

2CR RELAY

THIS RELAY IS VERY IMPORTANT AND SHOULD BE WIRED EXACTLY AS SHOWN. THE MAIN FUNCTION OF THIS RELAY IS TO HOLD PUMP "OFF" WHEN SELECTOR SWITCH OR SW1 REMOTE SWITCH HAS TOLD PUMP TO GO "OFF". IF WIRED WRONG, THE PUMP WILL CYCLE ON-OFF-ON-OFF. WHEN THE SW2 MICRO SWITCH ARM OF X105 SWITCH ASSEMBLY IS MOVED EVER SO SLIGHTLY.

3CR RELAY

THIS RELAY IS THE POWER FAILURE RELAY. WHEN NORMAL POWER IS AVAILABLE, 3CR IS ENERGIZED AND THE CONTACTS ARE CLOSED. THIS RELAY IS ENERGIZED WITH PUMP ON OR PUMP OFF.

DURING NORMAL PUMP OPERATION THE 3CR CONTACTS ARE CLOSED. BUT WHEN AN INTERMITTENT POWER FAILURE ("BROWN OUT") OCCURS, THIS RELAY DROPS OUT AND ALL OF ITS CONTACTS OPEN.

WHEN ELECTRIC POWER IS QUICKLY RE-ESTABLISHED, THE PUMP WILL NOT COME ON, EVEN THROUGH SIGNALLED BY SW1 "PUMP AUTO ON". THIS PREVENTS THE PUMP FROM RESTARTING WITH A PARTIALLY OPEN PUMP CONTROL VALVE.

AFTER THE PUMP CONTROL VALVE HAS MOVED HYDRAULICALLY TO ITS NORMALLY OPEN (61 SERIES) OR NORMALLY CLOSED (60 SERIES) POSITION, IT MOVES SW2 TO THE OPEN (N.O.) POSITION. THIS LETS ELECTRICITY GO FROM L1 THROUGH SW2 TO ENERGIZE COIL OF 3CR RELAY AT L2. 3CR CONTACTS CLOSE AND THE CIRCUIT WILL THEN BE READY FOR "PUMP SIGNALLED ON" SEQUENCE AS IF IT WERE A NORMAL SITUATION. THE 3CR RELAY GIVES THE PUMP A "DELAYED RESET" APPEARANCE.

CAD REVISION RECORD - DO NOT REVERSE MANUALLY

DATE

BY

DESCRIPTION

SEE SHEET 1

LTR

THIS DRAWING IS THE PROPERTY OF CLA-VAL CO. AND SAME AND COPIES MADE THEREOF, IF ANY, SHALL BE RETURNED TO IT UPON DEMAND. DELIVERY AND DISCLOSURE HEREOF ARE SOLELY UPON CONDITION THAT THE SAME SHALL NOT BE USED, COPIED OR REPRODUCED, NOR SHALL THE SUBJECT HEREOF BE DISCLOSED IN ANY MANNER TO ANYONE FOR ANY PURPOSE, EXCEPT AS HEREIN AUTHORIZED, WITHOUT PRIOR WRITTEN APPROVAL OF CLA-VAL CO. THIS DRAWING IS SUBMITTED CONFIDENTIALLY AND MAY NOT BE USED IN THE MANUFACTURE OF ANY MATERIAL OR PRODUCT OTHER THAN SUCH MATERIALS AND PRODUCTS FURNISHED TO CLA-VAL CO. WHETHER OR NOT THE EQUIPMENT OR INFORMATION SHOWN HEREON IS PATENTED OR OTHERWISE PROTECTED, FULL TITLE AND COPYRIGHTS, IF ANY, IN AND TO THIS DRAWING AND/OR INFORMATION DELIVERED OR SUBMITTED ARE FULLY RESERVED CLA-VAL CO.

AK	07-10-08	BB	ADDED PN'S 67783-62B (NED 62200)
AK	08-14-08	BC	ADDED PN'S 67783-63K (NED 62218)
PC	10-1-2008	BD	ADDED PN 67783-64H (NED 62446)
CAD REVISION RECORD - DO NOT REVISE MANUALLY		BY	DATE
LTR	DESCRIPTION	AK	03-14-06
A-AY	SEE REVISION FILE		
BA	ADDED PN'S 67783-59H, 67783-60F & 67783-61D (ECO 20434)		

 CLA-VAL CO. NEWPORT BEACH, CALIFORNIA	CATALOG NO.	DRAWING NO.	REV
		67783	BD
TYPE OF VALVE AND MAIN FEATURES		DESIGN	
<p style="text-align: center;">CK2 COCK/BALL VALVE</p>		DRAWN	MGR 4-02-80
		CHK'D	KD 4-03-80
		APV'D	CH 4-07-80

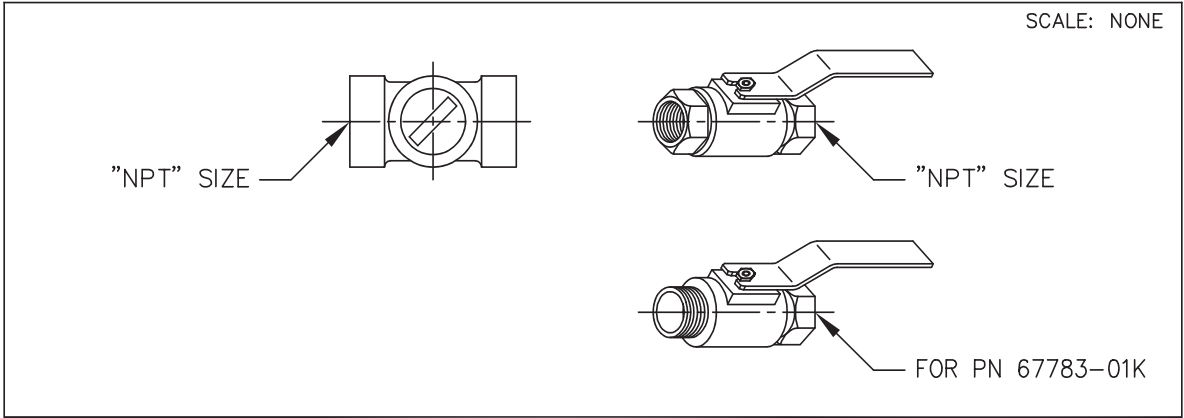

CLA-VAL PART NO. AND MATERIAL								
BRONZE WITH HANDLE	STEEL WITH HANDLE	IRON WITH HANDLE	316 SST WITH HANDLE	316 SST W/ LOCKING HANDLE	BRONZE WITH HANDLE	MONEL WITH HANDLE	MONEL W/ LOCKING HANDLE	SIZE "NPT"
67783-01K*	-09C	-17F	-25J SUPSD BY-26G		-41F SUPSD BY-01K			1/8"
-02H	-10A	-18D	-26G	-51E SUPSD BY-26G -52C	-42D SUPSD BY-02H	-55F		1/4"
-03F * -59H***	-11J	-19B	-27E	-46E SUPSD BY-27E -53A	-45G -57B * *	-48A SUPSD BY-49J	-63K	3/8"
-04D -60F ***	-12G	-20K	-28C	-54J	-43B SUPSD BY-04D	-49J	-62B	1/2"
-05A -61D ***	-13E	-21H	-29A	-64H	-44K SUPSD BY-05A	-56D		3/4"
-06J	-14C	-22F	-30J			-58K		1"
-07G	-15K	-23D	-31G					1 1/4"
-08E	-16H	-24B	-32E					1 1/2"
-50G			-47C					2"

- * SEE ENGINEERING APPROVED VENDORS TABLE (SHEET 2 OF 2).
- ** HAMMOND VALVE 8501 ONLY.
- *** WILKINS CK2 (SEE SHEET 2 OF 2)

"THIS DRAWING IS THE PROPERTY OF CLA-VAL CO. AND SAME AND COPIES MADE THEREOF, IF ANY, SHALL BE RETURNED TO IT UPON DEMAND. DELIVERY AND DISCLOSURE HEREOF ARE SOLELY UPON CONDITION THAT THE SAME SHALL NOT BE USED, COPIED OR REPRODUCED, NOR SHALL THE SUBJECT HEREOF BE DISCLOSED IN ANY MANNER TO ANYONE FOR ANY PURPOSE, EXCEPT AS HEREIN AUTHORIZED, WITHOUT PRIOR WRITTEN APPROVAL OF CLA-VAL CO. THIS DRAWING IS SUBMITTED CONFIDENTIALLY AND MAY NOT BE USED IN THE MANUFACTURE OF ANY MATERIAL OR PRODUCT OTHER THAN SUCH MATERIALS AND PRODUCTS FURNISHED TO CLA-VAL CO. WHETHER OR NOT THE EQUIPMENT OR INFORMATION SHOWN HEREON IS PATENTED OR OTHERWISE PROTECTED, FULL TITLE AND COPYRIGHTS, IF ANY, IN AND TO THIS DRAWING AND/OR INFORMATION DELIVERED OR SUBMITTED ARE FULLY RESERVED CLA-VAL CO."



— MODEL — **X46**

Flow Clean Strainer



X46A Straight

- Self Scrubbing Cleaning Action
- Straight Type or Angle Type

The Cla-Val Model X46 Strainer is designed to prevent passage of foreign particles larger than .015". It is especially effective against such contaminant as algae, mud, scale, wood pulp, moss, and root fibers. There is a model for every Cla-Val. valve.

X46B Angle



The X46 Flow Clean strainer operates on a velocity principle utilizing the circular "air foil" section to make it self cleaning. Impingement of particles is on the "leading edge" only. The low pressure area on the downstream side of the screen prevents foreign particles from clogging the screen. There is also a scouring action, due to eddy currents, which keeps most of the screen area clean.

Dimensions (In Inches)

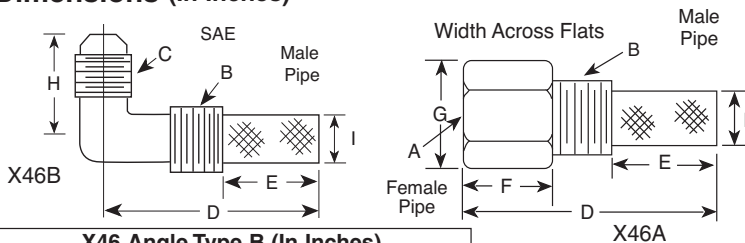

B(NPT)	C(SAE)	D	E	H	I
1/8	1/4	1-3/8	5/8	7/8	1/4
1/4	1/4	1-3/4	3/4	1	3/8
3/8	1/4	2	7/8	1	1/2
3/8	3/8	1-7/8	7/8	1	1/2
1/2	3/8	2-3/8	1	1-1/4	5/8

A (NPT)	B (NPT)	D	E	F	G	I
1/8	1/8	1-3/4	3/4	1/2	1/2	1/4
1/4	1/4	2-1/4	1	3/4	3/4	3/8
3/8	3/8	2-1/2	1	7/8	7/8	1/2
3/8	1/2	2-1/2	1-1/4	1/2	7/8	3/4
1/2	1/2	3	1-1/4	1	1-1/8	3/4
3/8	3/4	3-3/8	2	1/2	1	7/8
3/4	3/4	4	2	1	1-1/2	7/8
3/8	1	4-1/4	2-3/4	1/2	1-3/8	7/8
1	1	4-1/2	2-3/4	1-1/4	1-3/4	7/8
1/2	1	4-1/4	2-3/4	1/2	1-3/8	7/8

When Ordering, Please Specify:

- Catalog Number X46
- Straight Type or Angle Type
- Size Inserted Into and Size Connection
- Materials

INSTALLATION

The strainer is designed for use in conjunction with a Cla-Val Main Valve, but can be installed in any piping system where there is a moving fluid stream to keep it clean. When it is used with the Cla-Val Valve, it is threaded into the upstream body port provided for it on the side of the valve. It projects through the side of the Main Valve into the flow stream. All liquid shunted to the pilot control system and to the cover chamber of the Main Valve passes through the X46 Flow Clean Strainer.

INSPECTION

Inspect internal and external threads for damage or evidence of cross-threading. Check inner and outer screens for clogging, embedded foreign particles, breaks, cracks, corrosion, fatigue, and other signs of damage.

DISASSEMBLY

Do not attempt to remove the screens from the strainer housing.

CLEANING

After inspection, cleaning of the X46 can begin. Water service usually will produce mineral or lime deposits on metal parts in contact with water. These deposits can be cleaned by dipping X46 in a 5-percent muriatic acid solution just long enough for deposit to dissolve. This will remove most of the common types of deposits.

Caution: use extreme care when handling acid. If the deposit is not removed by acid, then a fine grit (400) wet or dry sandpaper can be used with water. Rinse parts in water before handling. An appropriate solvent can clean parts used in fueling service. Dry with compressed air or a clean, lint-free cloth. Protect from damage and dust until reassembled.

REPLACEMENT

If there is any sign of damage, or if there is the slightest doubt that the Model X46 Flow Clean Strainer may not afford completely satisfactory operation, replace it. Use Inspection steps as a guide. Neither inner screen, outer screen, nor housing is furnished as a replacement part. Replace Model X46 Flow Clean Strainer as a complete unit.

When ordering replacement Flow-Clean Strainers, it is important to determine pipe size of the tapped hole into which the strainer will be inserted (refer to column A or F), and the size of the external connection (refer to column B or G).



X43 Strainer

ITEM	DESCRIPTION	MATERIAL
1	Pipe Plug	Steel
2	Strainer Plug	Brass
3	Gasket	Copper
4	Screen	SST
5	Body	Brass

No parts available. Replacement assembly only.

Standard 60 mesh pilot system strainer for fluid service.

Size	Stock Number
3/8 x 3/8	33450J

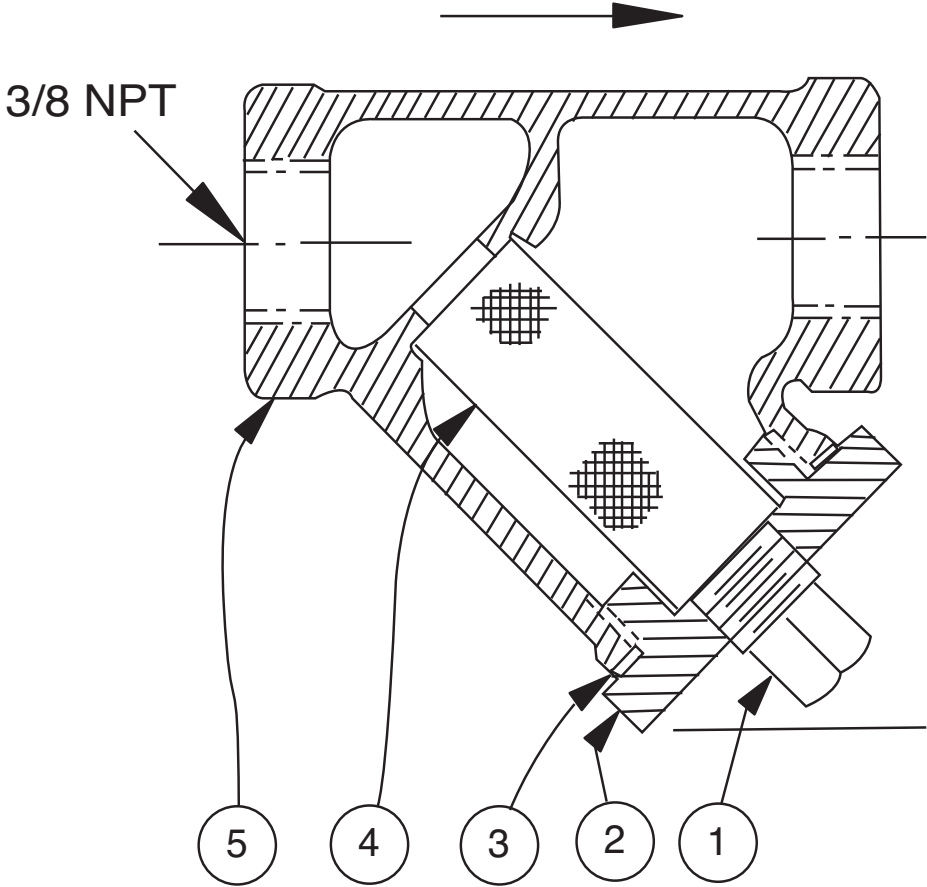

Proper Identification

For ordering repair kits, replacement parts, or for inquiries concerning valve operation, it is important to properly identify Cla-Val products already in service by including all nameplate data with your inquiry. Pertinent product data includes valve function, size, material, pressure rating, end details, type of pilot controls used and control adjustment ranges.

Identification Plates

For product identification, cast-in body markings are supplemented by identification plates as illustrated on this page. The plates, depending on type and size of product, are mounted in the most practical position. **It is extremely important that these identification plates are not painted over, removed, or in any other way rendered illegible.**

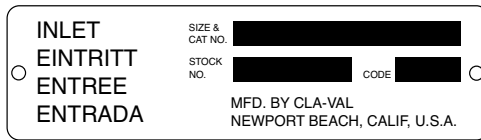

This brass plate appears on valves sized 2 1/2" and larger and is located on the top of the inlet flange.

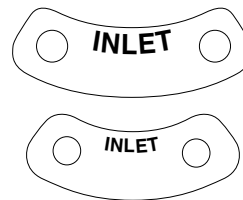

These two brass plates appear on 3/8", 1/2", and 3/4" size valves and are located on the valve cover.



This brass plate appears on altitude valves only and is found on top of the outlet flange.

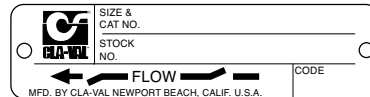

These two brass plates appear on threaded valves 1" through 3" size or flanged valves 1" through 2". It is located on only one side of the valve body.

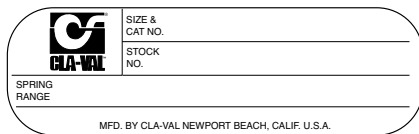

This tag is affixed to the cover of the pilot control valve. The adjustment range appears in the spring range section.

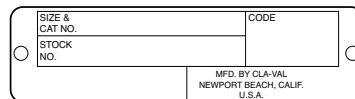

This brass plate is used to identify pilot control valves. The adjustment range is stamped into the plate.

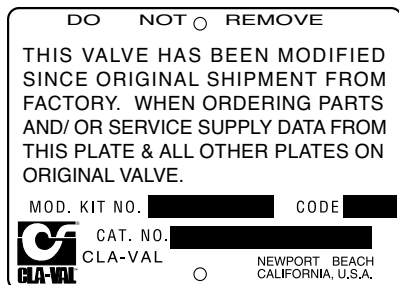

This aluminum plate is included in pilot system modification kits and is to be wired to the new pilot control system after installation.

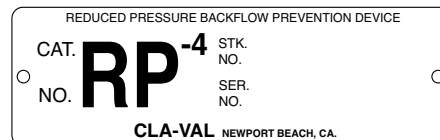

This brass plate is used on our backflow prevention assemblies. It is located on the side of the Number Two check (2" through 10"). The serial number of the assembly is also stamped on the top of the inlet flange of the Number One check.

HOW TO ORDER

Because of the vast number of possible configurations and combinations available, many valves and controls are not shown in published product and price lists. For ordering information, price and availability on product that are not listed, please contact your local Cla-Val office or our factory office located at:

P. O. Box 1325
Newport Beach, California 92659-0325
(949) 722-4800
FAX (949) 548-5441

SPECIFY WHEN ORDERING

- Model Number
- Globe or Angle Pattern
- Adjustment Range (As Applicable)
- Valve Size
- Threaded or Flanged
- Body and Trim Materials
- Optional Features
- Pressure Class

UNLESS OTHERWISE SPECIFIED

- Globe or angle pattern are the same price
- Ductile iron body and bronze trim are standard
- X46 Flow Clean Strainer or X43 "Y" Strainer are included
- CK2 Isolation Valves are included in price on 4" and larger valve sizes (6" and larger on 600 Series)

LIMITED WARRANTY

Automatic valves and controls as manufactured by Cla-Val are warranted for three years from date of shipment against manufacturing defects in material and workmanship that develop in the service for which they are designed, provided the products are installed and used in accordance with all applicable instructions and limitations issued by Cla-Val. Electronic components manufactured by Cla-Val are warranted for one year from the date of shipment.

We will repair or replace defective material, free of charge, that is returned to our factory, transportation charges prepaid, if upon inspection, the material is found to have been defective at time of original shipment. This warranty is expressly conditioned on the purchaser's providing written notification to Cla-Val immediate upon discovery of the defect.

Components used by Cla-Val but manufactured by others, are warranted only to the extent of that manufacturer's guarantee.

This warranty shall not apply if the product has been altered or repaired by others, Cla-Val shall make no allowance or credit for such repairs or alterations unless authorized in writing by Cla-Val.

DISCLAIMER OF WARRANTIES AND LIMITATIONS OF LIABILITY

The foregoing warranty is exclusive and in lieu of all other warranties and representations, whether expressed, implied, oral or written, including but not limited to any implied warranties or merchantability or fitness for a particular purpose. All such other warranties and representations are hereby cancelled.

Cla-Val shall not be liable for any incidental or consequential loss, damage or expense arising directly or indirectly from the use of the product. Cla-Val shall not be liable for any damages or charges for labor or expense in making repairs or adjustments to the product. Cla-Val shall not be liable for any damages or charges sustained in the adaptation or use of its engineering data and services. No representative of Cla-Val may change any of the foregoing or assume any additional liability or responsibility in connection with the product. The liability of Cla-Val is limited to material replacements F.O.B. Newport Beach, California.

TERMS OF SALE

ACCEPTANCE OF ORDERS

All orders are subject to acceptance by our main office at Newport Beach, California.

CREDIT TERMS

Credit terms are net thirty (30) days from date of invoice.

PURCHASE ORDER FORMS

Orders submitted on customer's own purchase order forms will be accepted only with the express understanding that no statements, clauses, or conditions contained in said order form will be binding on the Seller if they in any way modify the Seller's own terms and conditions of sales.

PRODUCT CHANGES

The right is reserved to make changes in pattern, design or materials when deemed necessary, without prior notice.

PRICES

All prices are F.O.B. Newport Beach, California unless expressly stated otherwise on our acknowledgement of the order. Prices are subject to change without notice. The prices at which any order is accepted are subject to adjustment to the Seller's price in effect at the time of shipment. Prices do not include sales, excise, municipal, state or any other Government taxes. Minimum order charge \$100.00.

RESPONSIBILITY

We will not be responsible for delays resulting from strikes, accidents, negligence of carriers, or other causes beyond our control. Also, we will not be liable for any unauthorized product alterations or charges accruing there from.

RISK

All goods are shipped at the risk of the purchaser after they have been delivered by to the carrier. Claims for error, shortages, etc., must be made upon receipt of goods.

EXPORT SHIPMENTS

Export shipments are subject to an additional charge for export packing.

RETURNED GOODS

1. Customers must obtain written approval from Cla-Val prior to returning any material.
2. Cla-Val reserves the right to refuse the return of any products.
3. Products more than six (6) months old cannot be returned for credit.
4. Specially produced, non-standard models cannot be returned for credit.
5. Rubber goods such as diaphragms, discs, o-rings, etc., cannot be returned for credit, unless as part of an unopened vacuum sealed repair kit which is less than six months old.
6. Goods authorized for return are subject to a 35% (\$100 minimum) restocking charge and a service charge for inspection, reconditioning, replacement of rubber parts, retesting, repainting and repackaging as required.
7. Authorized returned goods must be packaged and shipped prepaid to Cla-Val, 1701 Placentia Avenue, Costa Mesa, California 92627.



E-Product I.D. (R-3/2011)

CLA-VAL

PO Box 1325 Newport Beach CA 92659-0325
Phone: 949-722-4800 • Fax: 949-548-5441

CLA-VAL CANADA

4687 Christie Drive
Beamsville, Ontario
Canada L0R 1B4
Phone: 905-563-4963
Fax: 905-563-4040

CLA-VAL EUROPE

Chemin des Mesanges 1
CH-1032 Romanel/
Lausanne, Switzerland
Phone: 41-21-643-15-55
Fax: 41-21-643-15-50

©COPYRIGHT CLA-VAL 2011 Printed in USA
Specifications subject to change without notice.

www.cla-val.com

Represented By:



—MODEL—

REPAIR KITS

Complete Replacement Diaphragm Assemblies for 100-01 and 100-20 Hytrol Main Valves
For: Hytrol Main Valves with Ductile Iron, Bronze Trim Materials—**125/150 Pressure Class Only.**
FACTORY ASSEMBLED
 Includes: Stem, Disc Guide, Disc, Disc Retainer, Spacer Washers, Diaphragm, Diaphragm Washer and Stem Nut.

Valve Size	Diaphragm Assembly Stock Number		Valve Size	Diaphragm Assembly Stock Number	
	100-01	100-20		100-01	100-20
3/8" (Also 81-01)	49097K	N/A	6"	40456G	33273E
1/2" - 3/4" (Also 81-01)	C2518D	N/A	8"	45276D	40456G
1"	C2520K	N/A	10"	81752J	45276D
1 1/4"-1 1/2"	C2522 F	N/A	12"	85533J	81752J
2"	C2524B	N/A	14"	89067D	N/A
2 1/2"	C2523D	N/A	16"	89068B	85533J
3"	C2525J	C2524B	20"	N/A	89068B
4"	33273E	C2525J	24"	N/A	89068B

Repair Kits for 100-01/100-20 Hytrol Valves

For: Hytrol Main Valves—**125/150 Pressure Class Only.**
 Includes: Diaphragm, Disc (or Disc Assembly) and spare Spacer Washers.

Buna-N® Standard Material				Viton (For KB Valves)			
Valve Size	Repair Kit Stock Number		Valve Size	Repair Kit Stock Number			
	100-01	100-20		100-01	100-20		
3/8" (Also 81-01)	9169801K	N/A	3/8" (Also 81-01)	9169806J	N/A		
1/2" - 3/4" (Also 81-01)	9169802H	N/A	1/2" - 3/4" (Also 81-01)	9169807G	N/A		
1"	9169803F	N/A	1"	9169808E	N/A		
1 1/4" - 1 1/2"	9169804D	N/A	1 1/4" - 1 1/2"	9169809C	N/A		
2"	9169805A	N/A	2"	9169810A	N/A		
2 1/2"	9169811J	N/A	2 1/2"	9169817F	N/A		
3"	9169812G	9169805A	3"	9169818D	9169810A		
4"	9169813E	9169812G	4"	9169819B	9169818D		
6"	9169815K	9169813E	6"	9169820K	9169819B		
8"	9817901D	9169815K	8"	9169834A	9169820K		
10"	9817902B	9817901D					
12"	9817903K	9817902B					
14"	9817904H	N/A					
16"	9817905E	9817903K					
20"	N/A	9817905E					
24"	9817906C	9817905E					

When ordering, please give complete nameplate data of the valve and/or control being repaired.
MINIMUM ORDER CHARGE APPLIES.

Repair Kits for 100-02/100-21 Powertrol and 100-03/100-22 Powercheck Main Valves

For: Powertrol and Powercheck Main Valves—125/150 Pressure Class Only

Includes: Diaphragm, Disc (or Disc Assembly) and O-rings and full set of spare Spacer Washers.

Valve Size	Kit Stock Number 100-02	Valve Size	Kit Stock Number	
			100-02 & 100-03	100-21 & 100-22
3/8"	9169901H	2 1/2"	9169910J	N/A
1/2" & 3/4"	9169902F	3"	9169911G	9169905J
1"	9169903D	4"	9169912E	9169911G
1 1/4" & 1 1/2"	9169904B	6"	9169913C	9169912E
	9169905J	8"	99116G	9169913C
		10"	9169939H	99116G
		12"	9169937B	9169939H

Repair Kits for 100-04/100-23 Hy-Check Main Valves

Larger Sizes: Consult Factory.

For: Hy-Check Main Valves—125/150 Pressure Class Only

Includes: Diaphragm, Disc and O-Rings and full set of spare Spacer Washers.

Valve Size	Kit Stock Number		Valve Size	Kit Stock Number	
	100-04	100-23		100-04	100-23
4"	20210901B	N/A	12"	20210905H	20210904J
6"	20210902A	20210901B	14"	20210906G	N/A
8"	20210903K	20210902A	16"	20210907F	20210905H
10"	20210904J	20210903K	20"	N/A	20210907F
			24"	N/A	20210907F

Repair Kits for Pilot Control Valves (In Standard Materials Only)

Larger Sizes: Consult Factory.

Includes: Diaphragm, Disc (or Disc Assembly), O-Rings, Gaskets or spare Screws as appropriate.

BUNA-N® (Standard Material)				VITON (For KB Controls)	
Pilot Control	Kit Stock Number	Pilot Control	Kit Stock Number	Pilot Control	Kit Stock Number
CDB	9170006C	CFM-7	1263901K	CDB-KB	9170012A
CDB-30	9170023H	CFM-7A	1263901K	CRA-KB	N/A
CDB-31	9170024F	CFM-9	12223E	CRD-KB (w/bucking spring)	9170008J
CDB-7	9170017K	CRA (w/bucking spring)	9170001D	CRL-KB	9170013J
CDH-2	18225D	CRD (w/bucking spring)	9170002B	CDHS-2BKB	9170010E
CDHS-2	44607A	CRD (no bucking spring)	9170003K	CDHS-2FKB	9170011C
CDHS-2B	9170004H	CRD-18	20275401K	CDHS-18KB (no bucking spring)	9170009G
CDHS-2F	9170005E	CRD-22	98923G	102C-KB	1726202D
CDHS-3C-A2	24657K	CRL (55F, 55L)	9170007A		
CDHS-8A	2666901A	CRL/55L-60	9170033G		
CDHS-18	9170003K	CRL-4A	43413E		
CDS-4	9170014G	CRL-5 (55B)	65755B		
CDS-5	14200A	CRL-5A (55G)	20666E		
CDS-6	20119301A	CRL-18	20309801C		
CDS-6A	20349401C	CV	9170019F		
		X105L (O-ring)	00951E	Buna-N®	
CFCM-M1	1222301C	102B-1	1502201F	CRD Disc Ret. (Solid)	C5256H
CFM-2	12223E	102C-2	1726201F	CRD Disc Ret. (Spring)	C5255K
		102C-3	1726201F		

Repair Assemblies (In Standard Materials Only)

Control	Description	Stock Number
CF1-C1	Pilot Assembly Only	89541H
CF1-CI	Complete Float Control less Ball and Rod	89016A
CFC2-C1	Disc, Distributor and Seals	2674701E
CSM 11-A2-2	Mechanical Parts Assembly	97544B
CSM 11-A2-2	Pilot Assembly Only	18053K
33A 1"	Complete Internal Assembly and Seal	2036030B
33A 2"	Complete Internal Assembly and Seal	2040830J

When ordering, please give complete nameplate data of the valve and/or control being repaired. MINIMUM ORDER CHARGE APPLIES