

Model DSB-2 Dry Sprinkler Boot For Use With TFP Dry Type Sprinklers

General Description

The TYCO Model DSB-2 Dry Sprinkler Boot (Ref. Figure 1) is designed for use with TFP Dry Type Sprinklers. When properly installed, it will help close the air gap created by the clearance hole through a wall or ceiling through which the dry type sprinkler has penetrated.

The DSB-2 is intended predominately for use with clearance holes through freezer ceiling structures. In these types of installations, due to the greater temperature difference between the inside and outside of the freezer than found with other type installations, the potential for the formation of condensation in the sprinkler and subsequent ice build-up is increased. If this condensation is not controlled, ice build-up can occur that might damage the dry type sprinkler and/or prevent proper operation in a fire situation.

The DSB-2 is intended to help stop the air exchange between the inside and outside of the freezer (or any other type of similar construction) to help prevent transfer of moist air into the freezer space. The use of the DSB-2 provides a quick and efficient means of closing the air gap created by the dry type sprinkler clearance hole. The DSB-2 provides the added feature of eliminating the occurrence of cracking of some commonly used sealants, that subsequently allows the passage of moist air.

IMPORTANT

Refer to *Technical Data Sheet TFP2300* for warnings pertaining to regulatory and health information.

Always refer to *Technical Data Sheet TFP700* for the "INSTALLER WARNING" that provides cautions with respect to handling and installation of sprinkler systems and components. Improper handling and installation can permanently damage a sprinkler system or its components and cause the sprinkler to fail to operate in a fire situation or cause it to operate prematurely.

NOTICE

The Model DSB-2 Dry Sprinkler Boot described herein must be installed and maintained in compliance with this document, as well as with the applicable standards of the NATIONAL FIRE PROTECTION ASSOCIATION, in addition to the standards of any other authorities having jurisdiction. Failure to do so may impair the performance of these devices.

The owner is responsible for maintaining their fire protection system and devices in proper operating condition. Contact the installing contractor or product manufacturer with any questions.

Technical Data

Approvals

The TYCO Model DSB-2 Dry Sprinkler Boot does not require laboratory approval to be installed in accordance with the applicable standards of the NATIONAL FIRE PROTECTION ASSOCIATION. The use of the DSB-2 does not alter any of the applicable laboratory approvals for TFP Dry Type Sprinklers.

The 2007 edition of NFPA 13, Section 8.4.10.2 requires that dry sprinklers connected to wet pipe sprinkler systems protecting insulated freezer structures, the clearance space around the sprinkler barrel shall be sealed.

Dry Type Sprinkler Compatibility and Technical Data Sheet Reference

Series DS-1, Standard Response Standard Coverage, Pendent, Upright and HSW	TFP500
Series DS-1, Quick Response Standard Coverage, Pendent, Upright and HSW	TFP510
Series DS-C, Standard Coverage Concealed Pendent	TFP515
Series DS-ECC, Extended Coverage Concealed Pendent	TFP518



Series DS-1, Extended Coverage Horizontal Sidewall	TFP520
Series DS-2, Standard Coverage Pendent	TFP530
Series DS-2, Extended Coverage Pendent	TFP540
Series DS-3, ECOH Horizontal Sidewall	TFP550

NOTE: Use of the Model DSB-2 Dry Sprinkler Boot with non-TFP Dry Type Sprinklers will void the warranty. Failure may result due to dimensional differences in the outside diameter of the barrel. The DSB-2 has not been tested with any non-TFP Dry Type Sprinklers with regard to fit or performance.

Physical Characteristics

The Boot is EPDM, the Strap Ties are nylon, and the Adhesive is ethyl cyanoacrylate based. The adhesive is formulated for instant bonding of the Boot to metal, plastic, or rubber surfaces.

Design Criteria

There are four items to be considered: Dry Type Sprinklers, Clearance Hole, Exposure Length, and Sprinkler Fitting.

Dry Type Sprinklers

This Technical Data section provides a list of all of the compatible dry type sprinklers and their associated technical data sheets. Refer to the applicable technical data sheet for installation and maintenance information for the sprinkler being utilized.

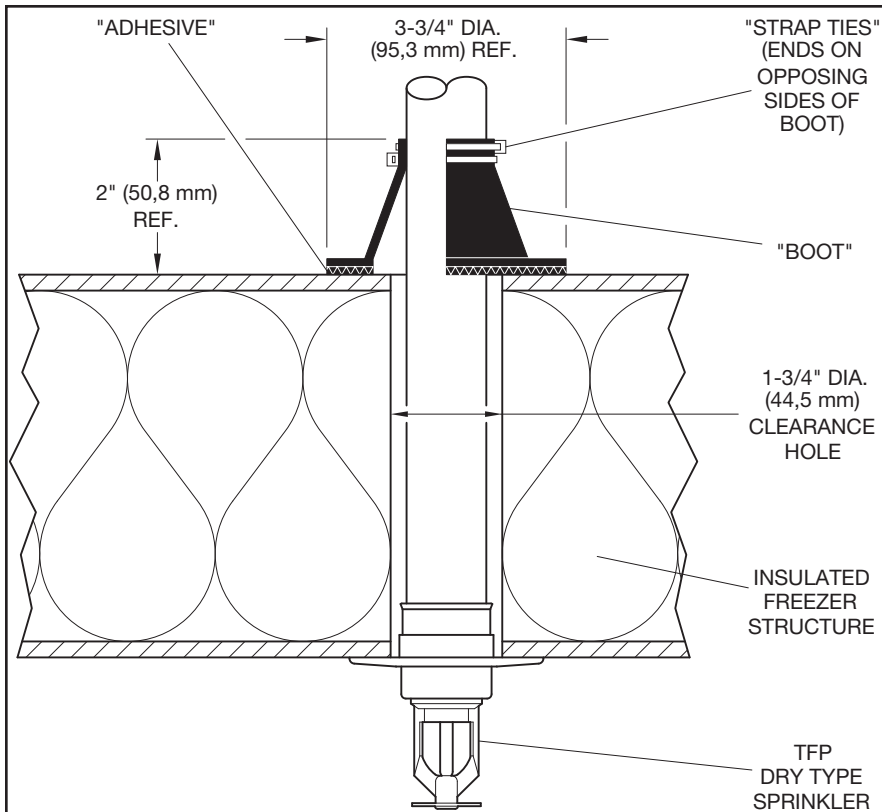

FIGURE 1
TYPICAL INSTALLATION OF MODEL DSB-2 DRY SPRINKLER BOOT
WITH SERIES DS-1 DRY PENDENT SPRINKLER

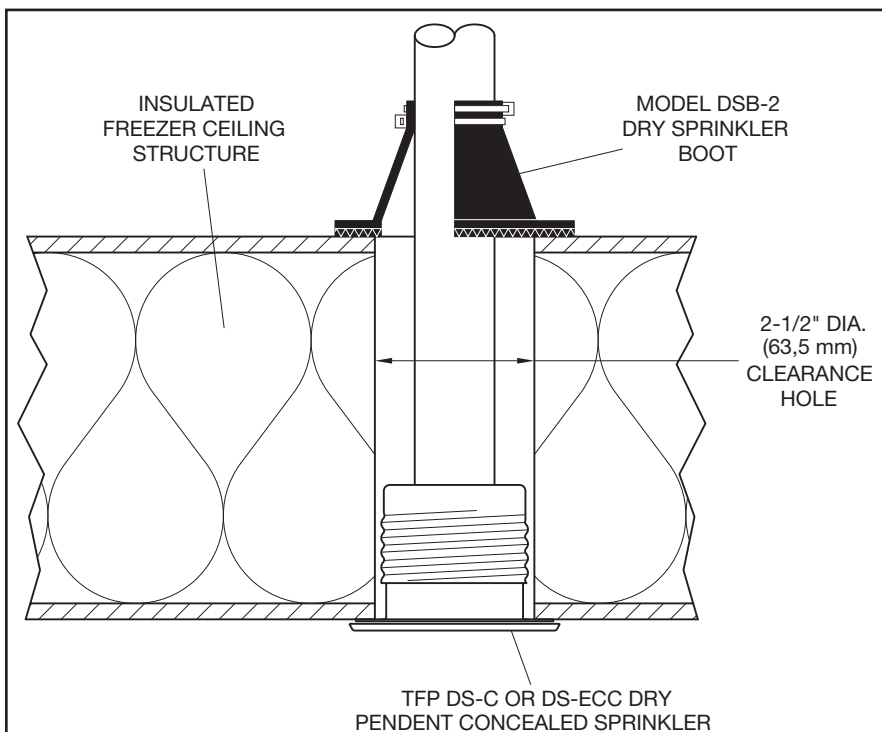

FIGURE 2
TYPICAL INSTALLATION OF MODEL DSB-2 DRY SPRINKLER BOOT
WITH SERIES DS-C DRY PENDENT CONCEALED SPRINKLER

NOTICE

The TFP Dry Type Sprinklers must be installed and maintained in compliance with the applicable technical data sheet. Failure to do so may impair the performance of these devices.

Clearance Hole

The Model DSB-2 Dry Sprinkler Boot may be used with a maximum 2-1/2 in. (63,5 mm) diameter clearance hole (i.e., the diameter of the hole in the ceiling or wall being penetrated by the dry type sprinkler, Ref. Figures 1 or 2). Based on the diameter of the Dry Type Sprinkler Barrel, the designated maximum clearance hole will compensate for non-centering of the Dry Type Sprinkler Barrel within the clearance hole. Where centering can be maintained, a clearance hole as large as 3 in. (76,2 mm) in diameter can be accommodated.

NOTE: The clearance hole adjacent to the DSB-2 cannot be larger than 2-1/2 in. (63,5 mm) diameter for a non-concentric installation or 3 in. (76,2 mm) diameter for a concentric installation. Otherwise, the DSB-2 cannot perform as intended by closing the air gap.

NOTE: Clearance holes greater than specified cannot be filled in with foam insulation, etc. In order for the DSB-2 to be effective in closing the air gap it must seat and seal against the smooth material of the ceiling or wall.

Exposure Length

When Dry Sprinklers are to be used in wet pipe sprinkler systems protecting areas subject to freezing temperatures (e.g., sprinkler drops into freezers), consideration must be given to the appropriate length of the sprinkler that will prevent freezing of the water in the connecting pipes due to conduction. When the temperature surrounding the wet pipe sprinkler system is maintained at a minimum temperature of 40°F (4°C), the following are the minimum recommended lengths between the face of the sprinkler fitting and the outside surface of the protected area (i.e., length exposed to minimum ambient temperature of 40°F (4°C) — Ref. Figure 3):

- 12 inches (300 mm) when the temperature within the protected area is -20°F (-29°C)
- 18 inches (450 mm) when the temperature within the protected area is -40°F (-40°C)
- 24 inches (600 mm) when the temperature within the protected area is -60°F (-51°C)

For protected area temperatures between those given above, the minimum recommended length from

the face of the fitting to the outside of the protected area may be determined by interpolating between the indicated values.

NOTE: The temperature within the protected area must be based on the lowest expected temperature. For example: a freezer may be rated at -20°F (-29°C), yet the condenser is emitting -30°F (-35°C). The dry sprinkler length must be calculated based on the lower temperature of -30°F (-35°C).

Sprinkler Fitting

TFP Dry Type Sprinklers must be installed in the 1 in. NPT outlet or run of a malleable or cast iron threaded tee as described in the applicable technical data sheets. With reference to Figure 4 and in conjunction with use in a wet pipe system, the sprinkler drop may be installed as shown. The information in Figure 4 may only be used where the sprinkler fitting and water filled pipe above the sprinkler fitting is not subject to freezing. In areas subject to freezing, the pipe connected to the dry type sprinkler must be configured to allow complete drainage as shown in Figure 5.

Installation

The TYCO Model DSB-2 must be installed in accordance with this section.

WARNING

The Adhesive contains cyanoacrylate ester. Irritation will occur when inhaled. This adhesive bonds skin in seconds. Contact through clothing may cause burns. EYE IRRITANT.

Always refer to the Material Safety Data Sheet for additional adhesive handling recommendations. The Material Safety Data Sheet should be obtained from the adhesive manufacturer via their web site noted on the adhesive container label before using the adhesive.

In case of skin contact, flush with water, and for eye contact seek medical attention.

Provide adequate ventilation in area of usage. When possible ventilation should be achieved by the use of local exhaust ventilation and good general ventilation. Vapors are heavier than air, therefore, downward ventilation should be used. When handling cyanoacrylate adhesives, goggles or safety glasses should always be worn. Polyethylene gloves should be used to protect the hands.

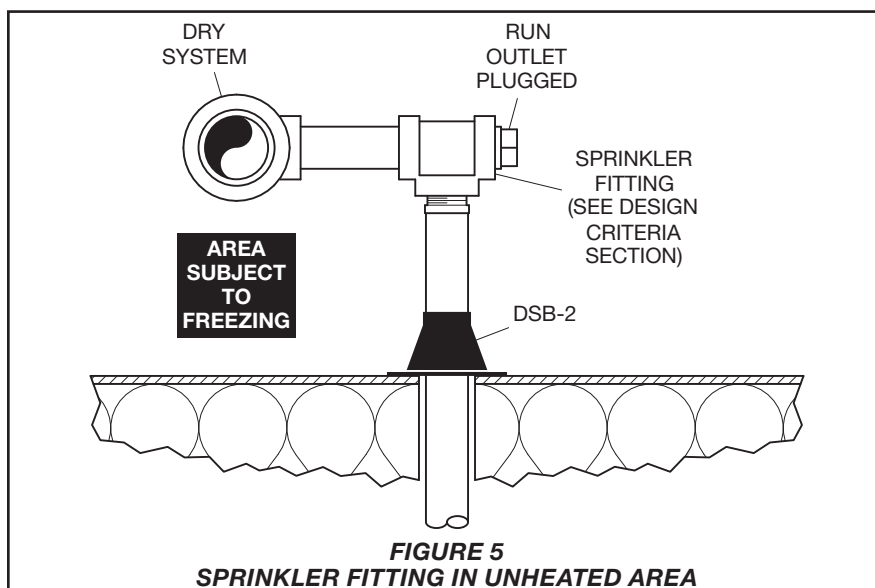
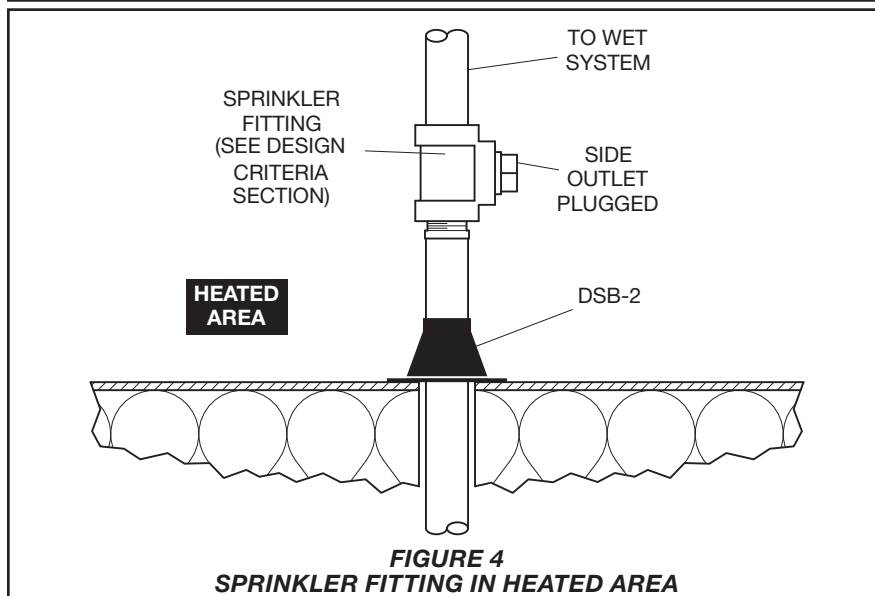
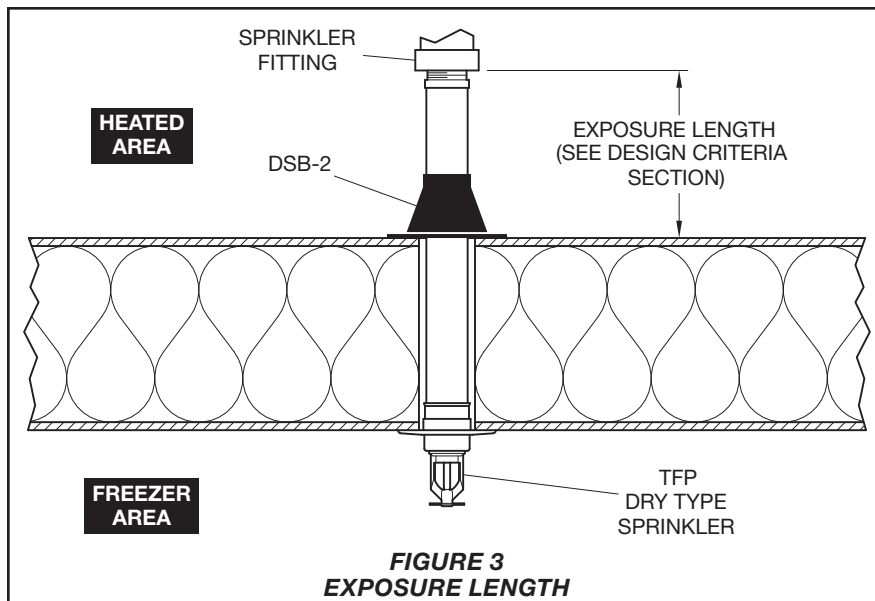

WARNING

DO NOT USE RUBBER OR CLOTH GLOVES. RUBBER GLOVES WILL BOND WHEN BROUGHT IN CONTACT WITH THE ADHESIVE AND POROUS COTTON GLOVES WILL ABSORB THE ADHESIVE AND BOND THE GLOVES TO THE SKIN.

Step 1. Prepare the clearance hole per the applicable TFP Dry Sprinkler Technical Data Sheet.

Step 2. Insert the dry sprinkler through the clearance hole and slide the Boot over threaded inlet of the dry sprinkler.

NOTE: *When installing on Series DS-2 Dry Sprinklers, the Boot will require stretching. The use of a grooved coupling gasket lubricant will ease installation. Use only a petroleum free silicone grooved coupling gasket lubricant to avoid freezing of the Dry Sprinkler Boot to the Dry Sprinkler.*

NOTE: *When sliding the Boot over the length of the Dry Sprinkler, sliding is easily accomplished by slightly squeezing the Boot around the cone area.*

Step 3. Thread the dry sprinkler into the sprinkler fitting per the applicable TFP Dry Sprinkler technical data sheet.

NOTE: *Refer to the sprinkler technical data sheet for tightening torque specifications. The use of higher levels of torque than specified may distort the sprinkler inlet with consequent leakage or impairment of the sprinkler.*

Step 4. Clean the contact surfaces of the Boot and the building (ceiling or wall) structure with a damp cloth. Moist surfaces will aid in a quick adhesion.

NOTE: *Use only a cloth that has been dampened with water. The use of other cleaning techniques, solvents, etc. may render the adhesive incapable of sealing.*

Step 5. Apply the provided Adhesive to the building structure in a zig-zag pattern. Refer to Warning regarding the adhesive.

Step 6. Slide the Boot so that it comes in contact with the building structure, and then press the Boot firmly against the building structure to help ensure that the Adhesive is fully applied to both surfaces.

NOTE: *When sliding the Boot over the length of the Dry Sprinkler, sliding is easily accomplished by slightly squeezing the Boot around the cone area.*

Step 7. Wait two minutes to allow the Adhesive to sufficiently cure and then apply the two Strap Ties. The Strap Ties are to be applied to the straight section of the Boot as shown in Figure 1 and so that the ends are on opposing sides of the Boot.

NOTE: *The ties are to be pulled sufficiently tight to the point that there is no gap between Dry Sprinkler Boot and the Dry Sprinkler. When properly installed a paper clip or wire of similar dimension cannot be slipped between the Dry Sprinkler Boot and the Dry Sprinkler.*

Care and Maintenance

The owner is responsible for the inspection, testing, and maintenance of their fire protection system and devices in compliance with this document, as well as with the applicable standards of the NATIONAL FIRE PROTECTION ASSOCIATION (e.g., NFPA 25), in addition to the standards of any other authorities having jurisdiction. Contact the installing contractor or product manufacturer with any questions.

Automatic sprinkler systems should be inspected, tested, and maintained by a qualified Inspection Service in accordance with local requirements and/or national codes.

Limited Warranty

For warranty terms and conditions, visit www.tyco-fire.com.

Ordering Procedure

Model DSB-2:

Specify: Model DSB-2 Dry Sprinkler Boot*, P/N 63-000-0-002

* Includes one Boot, two Strap Ties, and 1/3 oz of Adhesive (quantity of adhesive is sufficient for installing one Boot).