

Series V5748 STEEL FRAME - MILL FINISH

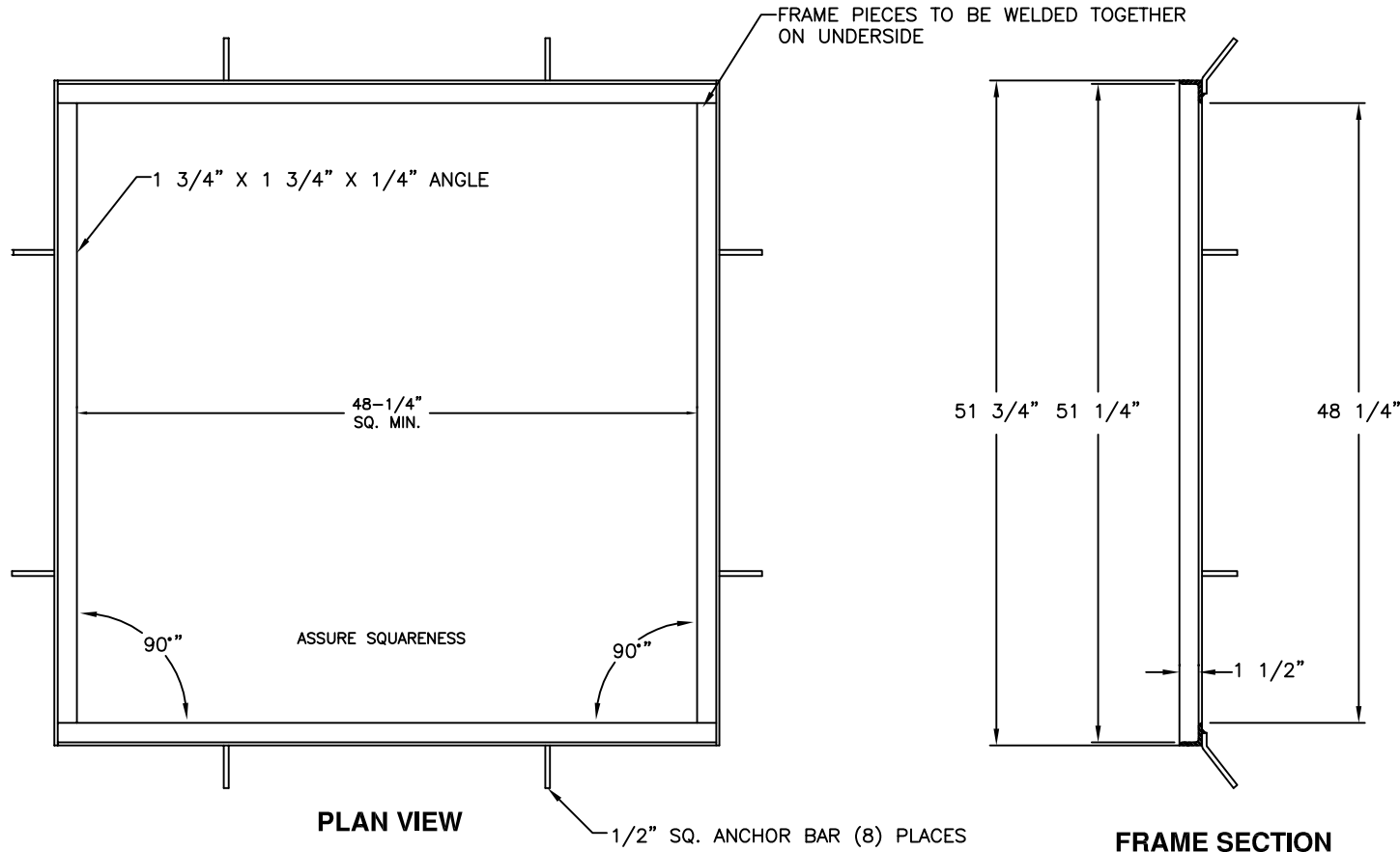

Product Number

45748010

Design Features

- Materials
ASTM A36
- Design Load
H2O Loading
- Open Area
n/a
- Coating
Mill Finish
- √ Designates Machined Surface

Certification

- ASTM A36
- Revised C/O to 48-1/4"
- Weight: 51 Lbs.
- Country of Origin: USA

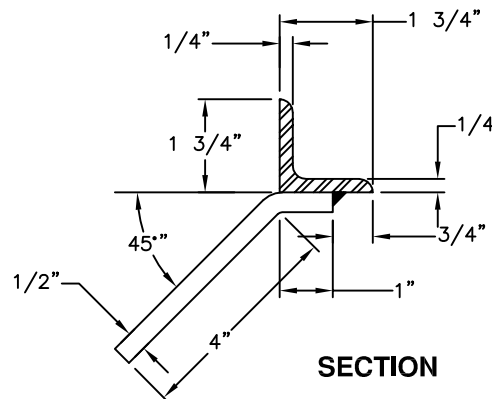
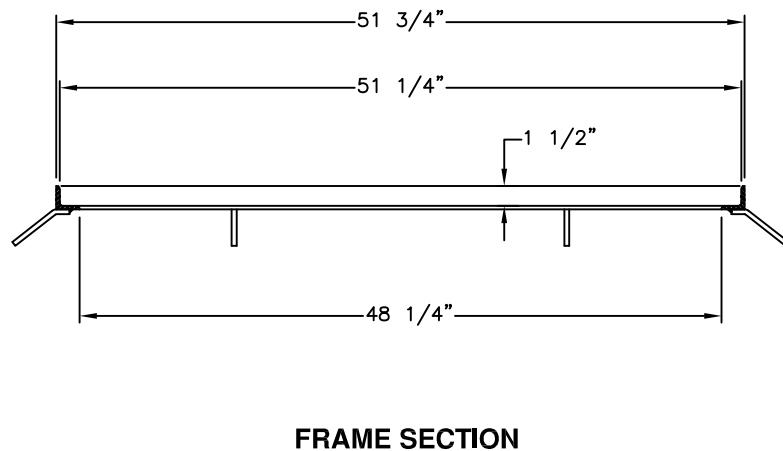

Drawing Revision

06/20/2007 Designer: CJC
03/08/2018 Revised By: BDD

Disclaimer

Weights (lbs./kg) dimensions (inches/mm) and drawings provided for your guidance. We reserve the right to modify specifications without prior notice.

CONFIDENTIAL: This drawing is the property of EJ GROUP, Inc., and embodies confidential information, registered marks, patents, trade secret information, and/or know how that is the property of EJ GROUP, Inc. Copyright © 2012 EJ GROUP, Inc. All rights reserved.

Contact

800 626 4653
ejco.com