

6" Long Press-On Collar

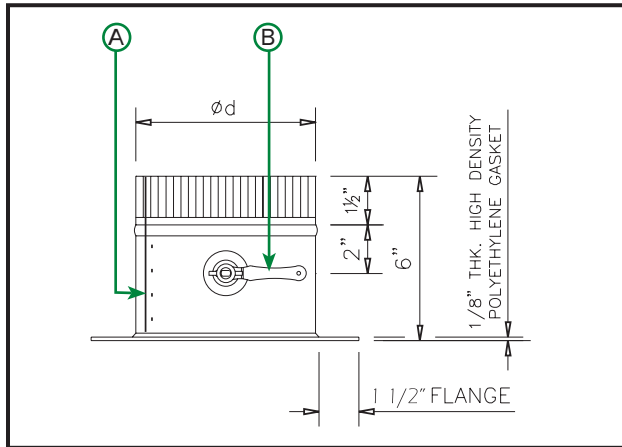

Technical Data

- Pre-sealed with gasket made of EPDM rubber and proprietary co-polymer
- Zero VOCs
- Galvanized Steel (ASTM A653 and A924)
- G-60 Galvanized Coating (ASTM A653 and ASTM A90)
- Available in Specialty Metals:
 - G-90 Galvanized Steel
 - Aluminum (ASTM B209 Alloy 3003 Temper H14)
 - 304 Stainless Steel (ASTM A480 2B Finish)
- Pressure Rating: Designed per SMACNA Third Edition 2005 Section 4.8 Figure 4-6 Branch Connections
- Dimensional Tolerance: $\pm 1/4"$

A. Collars now come standard with sealed joints! The riveted seam is sealed with the GreenSeam integral gasket. Unsealed fittings are available upon request.

B. Non-dampered collars are supplied with a 3/8" knock-out. Dampered collars are supplied with 24GA. damper blades and Ductmate's proprietary low-leakage hardware. See Appendix A.

Product Availability

Size (Ød)*	Gauge Availability		Quantity	
	26 Ga.	24 Ga.	Carton	Skid
4"	Yes	-	25	700
5"	Yes	Yes	25	700
6"	Yes	Yes	20	320
7"	Yes	Yes	20	200
8"	Yes	Yes	20	200
9"	Yes	Yes	10	140
10"	Yes	Yes	10	140
12"	Yes	Yes	10	90
14"	Yes	Yes	5	80
16"	-	Yes	5	50
18"	-	Yes	5	50
20"	-	Yes	2	36

Dampered fittings are available with 1 1/2" or 2" Stand-Off. See Appendix B on page 27.

Part Number Schematic

Example: **6POS15CR10GA26D38** = 6" Long Press-on Collar for 10" Pipe in 26Ga. Galv. Steel, with a Solid Rod Damper and 1 1/2" Stand-Off

S	6	PO	S15	C	R	10	GA	26	D	38
Scoop (Opt.)	Collar Length	Press-On Start Collar	Stand-Off S15 - 1 1/2" S2 - 2" (Opt. on Dampers Only)	End C - Crimped (Std.) P - Plain (Opt.)	Riveted	Collar Diameter (Ød)	Material GA-Galvanized (Std.) AL - Aluminum S4 - 304 S.S	Gauge GA - 26, 24 AL - 32 S4 - 26	Damper (Opt.)	3/8" Solid Rod (Opt. on Dampers Only) See Appendix C on page 28.

(Items in green denote available options)