



300 S. DAYTON ST.
 DAVISON, MI 48423
 PH: 810-503-9000
 FAX: 810-653-8714

FT-150

DESCRIPTION:

1 1/2 IN. FLEXIBLE "P" TRAP

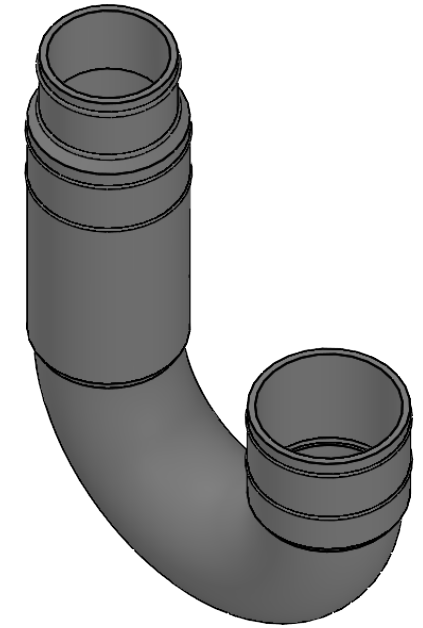
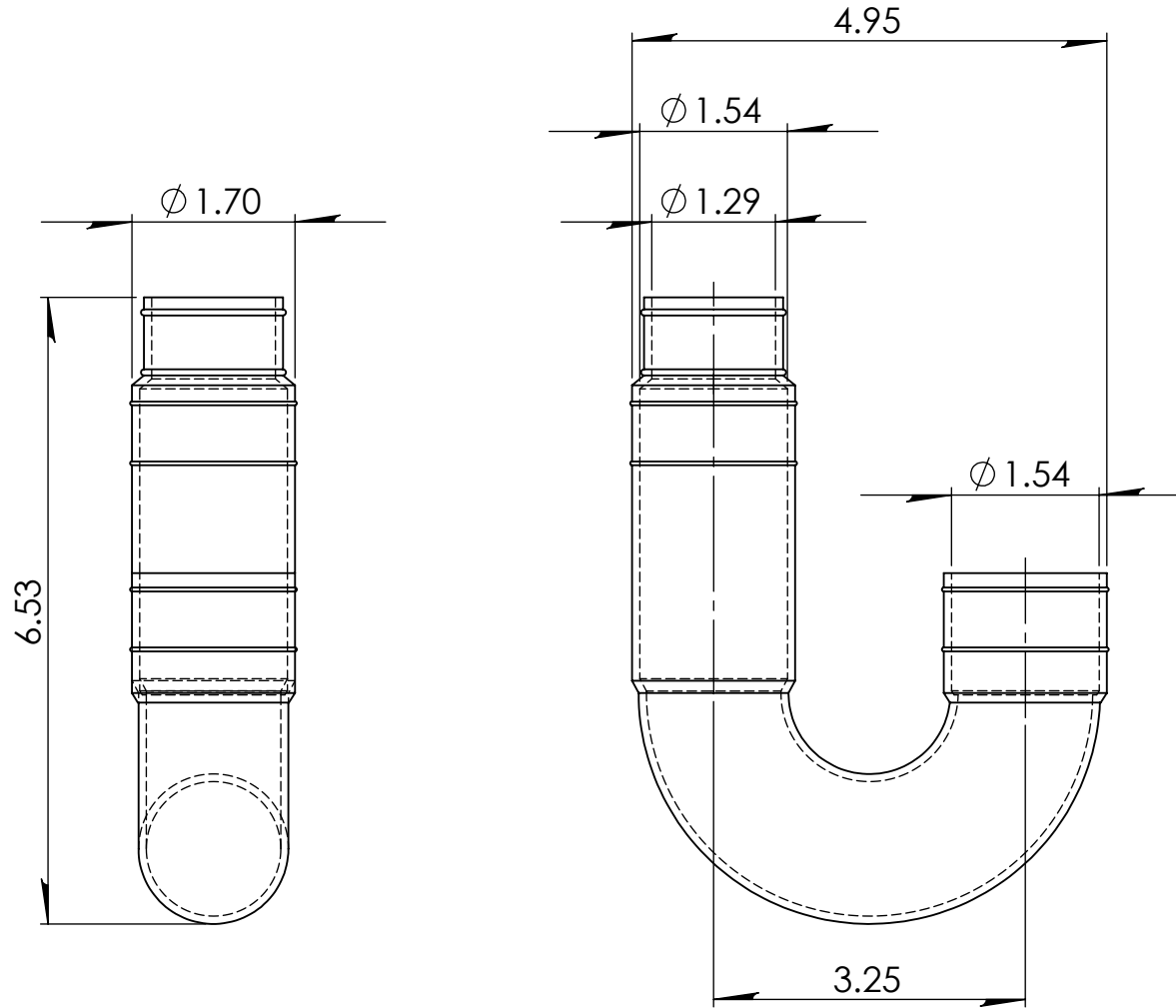

NOTE:

PROPRIETARY AND CONFIDENTIAL
 THE INFORMATION CONTAINED IN THIS
 DRAWING IS THE SOLE PROPERTY OF
 FERNCO, INC. ANY REPRODUCTION IN
 PART OR AS A WHOLE WITHOUT THE
 WRITTEN PERMISSION OF FERNCO, INC.
 IS PROHIBITED.

TOLERANCES:
 FRACTIONAL $\pm 1/4"$
 .XX = $\pm .06$
 ANG. = $+3^\circ$
 UNLESS OTHERWISE SPECIFIED

MATERIAL	PVC	CLAMPS USED	200 SERIES STAINLESS	UNITS:	INCHES	SIZE:	A	AUTHOR:	ELI MILLER	SCALE:	NOT TO SCALE
PART WEIGHT		INSTALLATION TORQUE	60 IN · LBS								
BOX QUANTITY		MIN/MAX TEMP.	-30/140 °F								
PRESSURE TESTED		ASTM	D5926	3RD ANGLE PROJECTION DO NOT SCALE DRAWING		CHECKER:		DATE:	3/2/2021		SHEET 1 OF 1