

NOTES:

- 1 5874PBF (ITEM 2) INCLUDES VRK5874 CARTRIDGE ASSEMBLY (ITEM 3) AND PBA6 FLANGED PUSH BUTTON (ITEM 4).

ITEM	DESCRIPTION	1011	1011HPS
1	BUBBLER HEAD, PCP	5705	5705
2	BUTTON, PUSH, PCP, FLANGED W/ VALVE	5874PBF	5874PBF
3	VALVE REPAIR KIT	VRK5874	VRK5874
4	BUTTON, PUSH, 5874, FLANGED	PBA6	PBA6
5	PANEL, BACK, F/ SATIN SWIRL OR HI-POL SS	0004012000	0004012023
**	FRAME, MOUNTING	MTGFR.DF2	MTGFR.DF2
7	STRAINER, WASTE ASSEMBLY, SCP OR PCP	6463	6463PCP
*	PANEL, ACCESS, SS SATIN OR HI-POL	6608	6608HPS
9	PLATE, BOTTOM, F/1000	PBM1000	PBM1000
10	INSERT, LAMINAR FLOW, 5705	0002850230	0002850230
*	DRIVER, NOZZLE, .25 HEX	0002082253	0002082253

\* DENOTES OPTIONAL PART.  
\*\* REQUIRED - SOLD SEPARATELY.

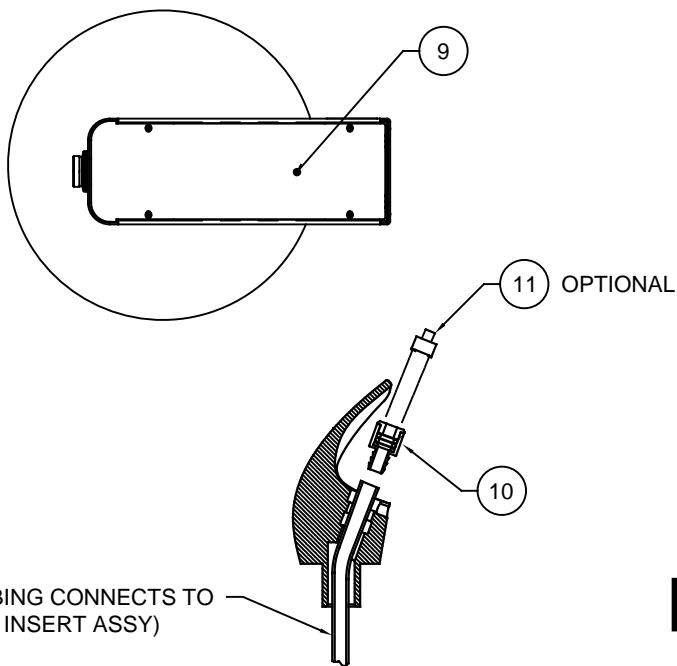
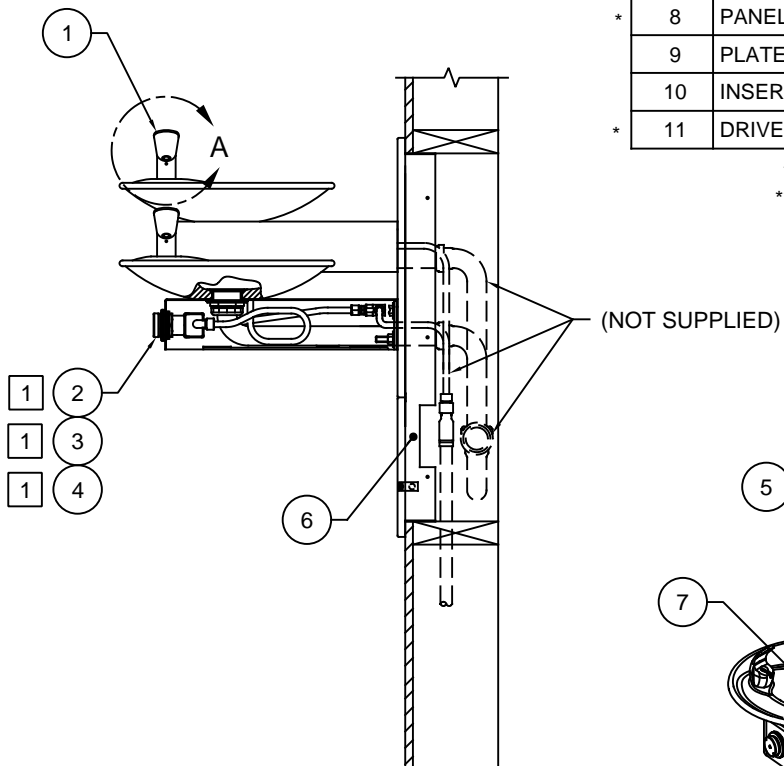

DETAIL A  
(ROTATED 90° INTO VIEW)

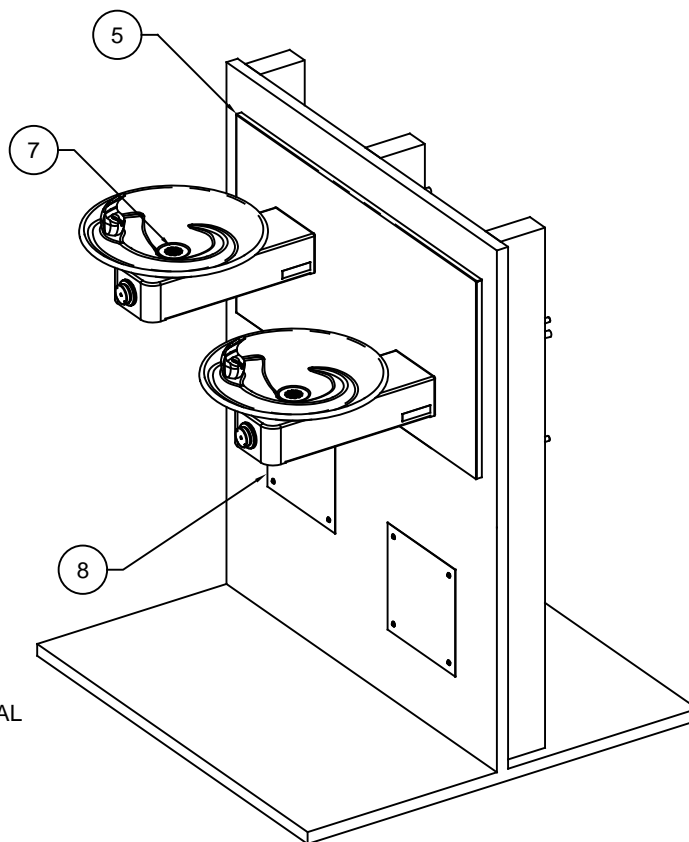

# PARTS BREAKDOWN

WHEN ORDERING PARTS PLEASE SPECIFY MODEL NUMBER.

		<b>Haws</b> <sup>®</sup>		1455 KLEPPE LANE SPARKS, NEVADA 89431 (775) 359-4712 FAX (775) 359-7424 E-MAIL: HAWS@HAWSCO.COM WEBSITE: WWW.HAWSCO.COM	
ECN NO.	REVISED PER	BY	MODEL(S)	PART NUMBER	
.	ECN: 5527	FV	1011MS/1011HPSMS	0002076519	
DRAWN	DATE	CHKD		REVISION	
PM	08/02/99	DP		12	
APPROVED	DATE				
FV	04/02/20				
SCALE: 1:8		DRAWING TYPE: PARTS BREAKDOWN		SIZE: A SHEET 1 OF 1	