

## QUARTZ LIMIT SWITCH FOR HAZARDOUS AREAS AND GENERAL PURPOSES

The Quartz is available in explosion/flame proof (QX), intrinsically safe and nonincendive (QN) and general purpose (QG) versions. The robust epoxy coated anodized aluminum construction makes this platform extremely durable and well suited for use in corrosive, heavy wash down environments. A broad range of switching, position transmitter and communication options may be selected to accommodate most applications. Options include 2, 4 or 6 mechanical or proximity switches, position transmitters with or without switches and the Dual Module with double SST or double Namur sensors or AS-i or FOUNDATION fieldbus communication capabilities.

### Features and Benefits

#### Enclosures Optimized for Environment

QX: Explosion-proof, water tight and corrosion-proof enclosure has ATEX II 2 G Ex d T5 and IECEx Ex d IIC T5 Gb certificates and can be used in Zone 1 areas. Also North American approvals exist.

QN: Intrinsically safe type with ATEX II 1 G, Ex ia IIC T5 certificate available with Namur sensors or passive switches for Div 1 / Zone 0 applications. Also North American approvals exist.

QG: General purpose type features a clear Lexan polycarbonate cover with mechanical switches. All enclosures are rated IP67 (NEMA 4, 4x, and 6).



#### Rapid Enclosure Access

Screw-on cover allows quick enclosure access, saving valuable maintenance and set-up time. The cover provides a vapor-tight seal and allows easy entry to internal components.

#### Quick Set Cams are Easy to Adjust

Touch and Tune switch settings allow you to make adjustments in seconds without the use of tools.

#### Wide Variety of Switching & Communication

Switching options include Dual Module sensors and communication, Maxx-Guard proximity switches and mechanical switches. Continuous signal output is available in a 4-20 mA position transmitter.

#### Faster Wiring

Pre-wired and labeled terminal strip enables quick and convenient attachment of field wires.

#### Dual Shaft O-ring Seals Eliminate Corrosion

Top inner and bottom outer shaft o-rings seal the drive bushing from both external corrosives and internal contaminants that enter the enclosure.

#### Special Drive Bushing Assures Long Cycle Life

The oil impregnated brass bushing maintains smooth operation and eliminates the potential for shaft seizure due to actuator shaft eccentricity.

#### Space Saving Visual Indication

Visual indicator offers excellent viewability without sacrificing accessibility or adding to space requirements.

### Speed Installation With LED Indication



Coordinated visual indicator and LEDs give you an extra measure of safety and increased convenience during plant start-up and operation. Green visual indication and green LED means the valve is open and the control circuit is properly operating. Red visual indication and red LED means the valve is closed and the control is properly matched.

### Consolidate Your Components and Minimize Costs

The Quartz design offers up to three conduit entries with extra wire terminations. By terminating solenoid valves in the switch enclosure, significant savings are realized by eliminating a junction box, wiring, conduit materials and labor.

### Save Space with Low Profile Design

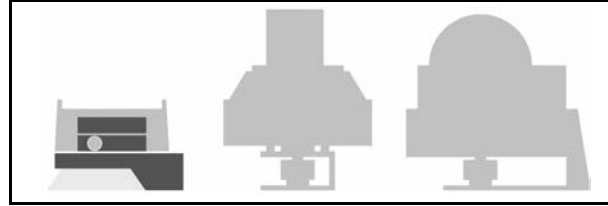

Clearance above the actuator is critical in complex piping systems. Quartz displays valve position and encloses all electrical components in a compact explosion-proof/ flame-proof compartment.

## SWITCH, SENSOR AND COMMUNICATION TYPES

### Mechanical Switches



Mechanical (SPDT) standard silver contact micro switches are ideal for high power applications and gold contacts for 24 VDC low power applications. Temperature range -40...+80 °C / -40...+176 °F

#### Silver Contacts ( \_V\_ )

Electrical Ratings 10 A at 250 VAC  
0.5 A at 125 VDC  
Operating Life 400,000 Cycles

Not recommended for electrical circuits operating at less than 20 mA at 24 VDC.

#### Gold Contacts ( \_W\_ )

Electrical Ratings 1.0 A at 125 VAC  
0.5 A at 30 VDC  
Operating Life 100,000 Cycles

### DPDT Switches ( \_14\_ )



Double-pole double-throw (DPDT) switches are available for isolation of two circuits operating at the same time. One DPDT operates identically to two SPDT being actuated simultaneously. Electrical Ratings 4.5 A at 250 VAC  
Operating Life 250,000 Cycles

Not recommended for electrical circuits operating at less than 20 mA at 24 VDC.

### Solid State SST ( \_X\_ )

Solid state SST proximity sensors are ideal for use in AC and DC circuits. They have unlimited operating life, are robust and well suited for general applications in control.

Operation Cam Selectable NO or NC  
Electrical Ratings 0.3 A at 125 VAC / VDC  
Leakage Current Less than 0.5 mA  
Maximum Voltage Drop 6.5 V at 10 mA  
Operating Life Unlimited  
Temperature range -40 ... +80 °C / -40 ... +176 °F

### Maxx-Guard Proximity Switches

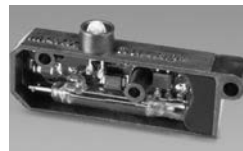

Maxx-Guard reed switches with SPDT tungsten contacts are suitable for 125 VAC and 240 VAC applications. SPDT rhodium contacts are designed for either 24 VDC or 125 VAC low power inputs. SPST ruthenium contacts are ideal for either

24VDC or 125VAC low power inputs.

Operating Life 5 million Cycles  
Seal Hermetically sealed  
Temperature range -40...+80 °C / -40...+176 °F

#### SPST ( \_L\_ )

Configuration With LED  
Electrical Ratings 150 mA at 30 VDC / 125 VAC  
Max. Voltage Drop 3.5 V at 10 mA  
6.5 V at 100 mA  
Contact Ruthenium

#### SPST ( \_P\_ )

Electrical Ratings 150 mA at 30 VDC / 125 VAC  
Max. Voltage Drop 0.1 V at 10 mA  
0.5 V at 100 mA  
Contact Ruthenium

#### SPDT ( \_G\_ )

Electrical Ratings 300 mA at 24 VDC  
200 mA at 120 VAC  
Max. Voltage Drop 0.1 V at 10 mA  
0.5 V at 100 mA  
Contact Rhodium

#### SPDT ( \_H\_ )

Electrical Ratings 240 VAC max; 3 A max  
100 W max; 2.0 W min  
Max. Voltage Drop 0.1 V at 10 mA  
0.5 V at 100 mA  
Contact Tungsten

**SPDT ( \_S\_ )**

Configuration	With LED
Electrical Ratings	300 mA at 125 VAC
Max. Voltage Drop	3.5 V at 10 mA 6.5 V at 100 mA
Contact	Tungsten

**P+F Inductive Proximity Sensors**

Inductive Pepperl + Fuchs proximity sensors may be selected for intrinsically safe or other special applications.

**A**

Type	NJ2-12GK-SN
Configuration	2-wire type, NAMUR NC, Conforms to DIN 19234
Operating voltage	5-25 VDC
Current ratings:	Target off: I > 3 mA, Target on: I < 1 mA
Temperature range	-40...+62 °C / -40...+144 °F

**E**

Type	NBB2-V3-E0-V5
Configuration	NPN, 3-wire type
Operating voltage	10-30 VDC
Current ratings	100 mA
Temperature range	-25...+80 °C / -13...+176 °F

**F**

Type	NBB2-V3-E2-V5
Configuration	PNP, 3-wire type
Operating voltage	10-30 VDC
Current ratings	100 mA
Temperature range	-25...+70 °C / -13...+158 °F

**N**

Type	NJ2-V3-N
Configuration	2-wire type, NAMUR NC, Conforms to DIN 19234
Nominal voltage	8 VDC
Current ratings	Target off: I > 3 mA, Target on: I < 1 mA
Temperature range	-25...+80 °C / -13...+176 °F

**Dual Module System**

The Dual Module integrates two separate sensor circuits and solenoid wire terminations in a fully sealed module. Sensor circuits are available in either SST switching or Namur outputs. Each SST sensor circuit and each Namur sensor circuit are electrically isolated. Although

they are packaged together they operate independently.

Temperature range: -40...+80 °C / -40...+176 °F

**SST Dual Module ( \_33\_ )**

Configuration:	2 solid state sensors, Cam selectable NO or NC
Indications:	2 wire termination points for one solenoid Target on sensor = LED on Target off sensor = LED off
Operating voltage:	8-125 V DC; 24-125 V AC
Voltage drop:	Max 6.5 V / 10 mA, 7.0 V / 100 mA
Current ratings:	
Max inrush:	2.0 A / 125 V DC / V AC
Max continuous:	0.3 A / 125 V DC / V AC
Minimum on current:	3.0 mA (AC), 2.0 mA (DC)
Leakage current:	Max 0.5 mA
Operating life:	Unlimited

**Namur Dual Module ( \_44\_ )**

Configuration:	2 Namur sensors, Normally Closed 2 wire termination points for one solenoid
Operating voltage:	6-29 V DC
Current ratings:	Target on (LED off) <1.0 mA Target off (LED on) >3.0 mA
Operating life:	Unlimited
Must use intrinsically safe repeater barrier.	
Namur sensors conform to DIN 19234 standard	

**AS-Interface Dual Module ( \_96\_ )**

Communication protocol:	AS-Interface (AS-i)
Configuration:	2 discrete inputs (sensors) 2 auxiliary discrete inputs 2 power outputs (for solenoids))
Aux. Input:	24 VDC at 120 mA (Self Powered)
Output voltage:	25 - 30 V DC
Max. output current:	160 mA, both outputs combined
Max. output power:	4 W, both outputs combined
AS-i version:	2.1
Devices per network:	31

**AS-Interface Dual Module ( \_97\_ )  
with Extended Addressing**

Communication protocol:	AS-Interface (AS-i)
Configuration:	2 discrete inputs (sensors) 2 auxiliary discrete inputs 1 power output (for solenoids))
Aux. Input:	24 VDC at 120 mA (Self Powered)
Output voltage:	25 - 30 V DC
Max. output current:	100 mA
Max. output power:	2.4 W
AS-i version:	2.1
Devices per network:	62

**FOUNDATION fieldbus Dual Module,  
Bus Powered ( \_93\_ )**

Communication protocol:	FOUNDATION fieldbus
Configuration:	2 discrete inputs (sensors) 2 discrete outputs (piezo valves)
Function blocks:	2 DI, 2 DO
Output:	2 mA / 6.5 V DC, current limited to 2 mA (bus powered), suitable for piezo valves.

**Position Transmitter**



The Quartz two-wire 4-20 mA position transmitter offers exceptional accuracy, reliability and performance. It may be directly attached to positioners or actuators in both linear and quarter-turn applications. You can select either standard or high-performance versions. Span Range: 35° to 270° (Adjustable)

- Linearity Error: +/- 0.85° (standard, \_5\_)  
+/- 0.35° (high performance, \_7\_)
- Cycle Life: Minimum 2 million rotations (\_5\_)  
Minimum 50 million rotations (\_7\_)
- Temperature range: -40...+80 °C / -40...+176 °F



**Other Specifications**

**Materials of Construction**

- Housing and Aluminum Cover: Epoxy coated anodized marine grade aluminum
- Clear Cover and Indicator: Lexan® Polycarbonate
- Elastomer Seals: Buna-N; Optional Viton and EPDM
- Drive Shaft: Stainless steel
- Drive Bushing: Brass, oil impregnated
- Fasteners: Stainless steel

**Unit weights**

**With aluminum cover**

- Short: 1.27 kg / 2.80 lbs
- Medium: 1.55 kg / 3.42 lbs
- Tall: 1.75 kg / 3.85 lbs

**With clear cover**

- Short: 1.20 kg / 2.64 lbs
- Medium: 1.27 kg / 2.79 lbs
- Tall: 1.39 kg / 3.06 lbs

**Certifications and Approvals**

**Explosion Proof (QX\_)**

- ATEX: II 2 G Ex d IIC T5
- IECEx: Ex d IIC T5 Gb
- cFMus: Class I, Div. 1, Groups BCD  
Class II, Div. 1, Groups EFG

**Intrinsically Safe (QN\_)**

- ATEX: II 1 G Ex ia IIC T5
- cFMus: Class I, II, III, Div 1, Groups A, B, C, D, E, F, G  
Class I, Div 2, Groups A, B, C, D (Nonincendive)

**Enclosure Protection**

- ATEX/IECEx: IP67
- NEC/CEC: 4, 4X & 6
- All electrical components are CE compliant.



**DIMENSIONS (mm)**

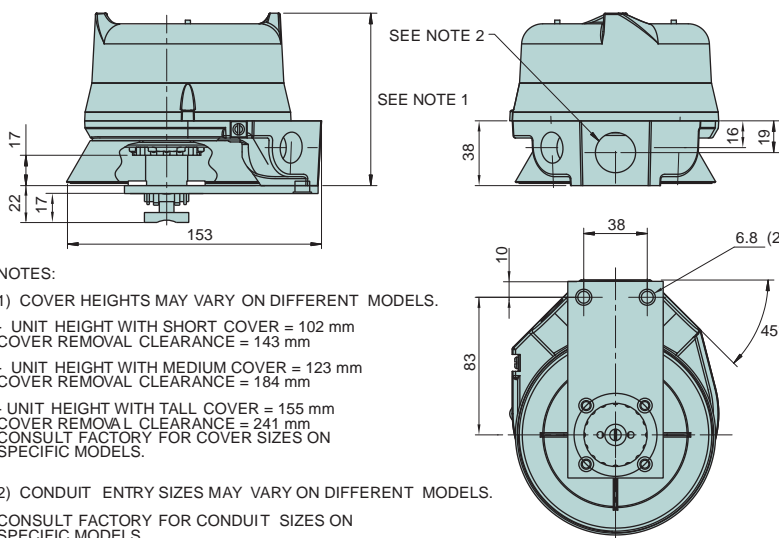

## HOW TO ORDER

## Quartz

1.	2.	3.	4.	5.	6.	7.	8.
QX	2	V	K	05	H	D	M

1. sign	PRODUCT GROUP
	<p><b>Quartz</b>, Limit switch with mechanical or proximity switches or position transmitter.</p>
QX	<p><b>ATEX</b> certification: ATEX II 2 G c T5 Ex d IIC T5 Ta = -40 °C to +80 °C IP67 Applicable to 4. sign "K" Applicable to all switch options, 3. sign, except "94".</p> <p><b>IECEX</b> certification: Ex d IIC T5 -40C ≤ Ta ≤ +80C Gb; IP67 Applicable to 4. sign "K" Applicable to all switch options, 3. sign, except "94".</p> <p><b>FM</b> certification: Explosionproof for Class I, Div. 1, Groups BCD, T5 Ta = -40 °C to +80 °C; Dust-ignitionproof for Class II, Div. 1, Groups EFG, T5 Ta = -40 °C to +80 °C; NEMA 4, 4X, 6 Applicable to 4. sign "B" Applicable to all switch options, 3. sign, except "A", "N", "44" or "94"</p> <p>Nonincendive for Class I, Div. 2, Groups ABCD, T5 Ta = -40 °C to +80 °C; Suitable for Class II, Div. 2, Groups FG, T5 Ta = -40 °C to +80 °C; NEMA 4, 4X, 6 Applicable to 4. sign "B" Applicable to all switch options, 3. sign, except "A", "N", "V", "W", "14", "44" or "94".</p> <p><b>cFM</b> (Canada) certification: Explosionproof for Class I, Div. 1, Groups BCD, T5 Ta = -40 °C to +80 °C; Dust-Protected for Class II, Div. 1, Groups EFG, T5 Ta = -40 °C to +80 °C; NEMA 4, 4X, 6 Applicable to 4. sign "B" Applicable to all switch options, 3. sign, except "A", "G", "N", "44" or "94"</p> <p>Ignition Protected Apparatus for Class I, Div. 2, Groups ABCD, T5 Ta = -40 °C to +80 °C; Suitable for Class II, Div. 2, Groups FG, T5 Ta = -40 °C to +80 °C; NEMA 4, 4X, 6 Applicable to 4. sign "B" Applicable to all switch options, 3. sign, except "A", "G", "N", "V", "W", "14", "44" or "94".</p> <p><b>Inmetro</b> certification: Ex d IIC T5 Gb IP67 Ta = -40 °C a +80 °C Applicable to all switch options, 3. sign, except "94". Applicable to 4. sign "G"</p>
QN	<p><b>NO</b> certificates: Applicable to all switch options, 3. sign and 4. sign "A"</p> <p><b>ATEX</b> certifications: II 1 G Ex ia IIC T5...T1 Ta*, IP67 See certificate for Ta* Applicable to 3. sign "44", "A" or "N" Applicable to 4. sign "K" or "A"</p> <p><b>FMus</b> and <b>cFM</b> certifications: Intrinsically safe for Class I, II, III, Divisions 1, Groups A, B, C, D, E, F, G Applicable to 3. sign "O", "44", "A" or "N" Applicable to 4. sign "B" or "P" Applicable to 5. sign "02" or "03"</p> <p>Nonincendive for Class I, Division 2, Groups A, B, C, D Not applicable to 3. sign "44", "A", "N", "G", "V", "W" or "14" Applicable to 4. sign "B" or "P" Applicable to 5. sign "02" or "03"</p>
QG	<p>General purpose type, <b>no certificates</b>. Not applicable to 2. sign "6" Only available with mechanical micro switches, 3. sign "V", "W" or "14". Applicable to 4. sign "P" only.</p>

2. sign	QUANTITY OF SWITCHES / FUNCTION
	2. sign to be empty when the 3. sign "14", "33", "44", "93", "94" or "96" is selected.
2	2 switches Not applicable to 3. sign "X", "14", "33", "44", "93", "94" or "96"
4	4 switches Not applicable to 3. sign A", "14", "33", "44", "93", "94" or "96"
6	6 switches Not applicable to 1. sign "QG" Applicable to 3. sign "V" or "W"
5	Standard position transmitter Accuracy +/-0.85°, cycle life 2 million rotations Two wire, 4-20 mA, supply source 10-40 VDC, max. load 700 Ω at 24 VDC With two switches or without switches. If 3. sign is "O", no switches are included. Not applicable to 3. sign "14", "33", "44", "93", "94" or "96"
7	High performance position transmitter Accuracy +/- 0.35°, cycle life 50 million rotations Two wire, 4-20 mA, supply source 10-40 VDC, max. load 700 Ω at 24 VDC With two switches or without switches. If 3. sign is "O", no switches are included. Not applicable to 3. sign "V", "W", "14", "33", "44", "93", "94" or "96"

3. sign	SWITCH TYPE
O	No switches. Applicable to 2. sign "5" or "7"
	<b>Inductive Proximity Switches</b> Temperature range -40...+80 °C / -40...+176 °F.
33	SST Sensor Dual Module, 2 switches, NO, 8-125 VDC / 24 - 125 VAC
X	SST Sensor, NO, 8-125 VDC / 24 - 125 VAC Not applicable to 2. sign "2", use 3. sign "33" for "2X"
E	P+F; NBB2-V3-E0-V5, NPN, 3-wiretype, 100 mA, 10 - 30 VDC Temperature range -25...+80 °C / -13...+176 °F.
F	P+F; NBB2-V3-E2-V5, PNP, 3-wiretype, 100 mA, 10 - 30 VDC Temperature range -25...+70 °C / -13...+158 °F.
	<b>Intrinsically Safe Inductive Proximity Switches</b> Temperature range -40...+80 °C / -40...+176 °F.
44	Namur Sensor Dual Module, 2 switches, (DIN 19234), 6 - 29 VDC; > 3 mA; 1 mA. Not applicable to 4. sign "B".
A	P+F; NJ2-12GK-SN, 2-wire type, DC; > 3 mA; < 1 mA. Temperature range -40 ... +62 °C / -40 ... 144 °F. Not applicable to 4. sign "B".
N	P+F; NJ2-V3-N, 2-wire type, DC; > 3 mA; < 1 mA. Temperature range -25...+80 °C / -13...+176 °F. Not applicable to 4. sign "B".
	<b>Reed Type Proximity Switches</b> Temperature range -40...+80 °C / -40...+176 °F.
P	Maxx-Guard, SPST, 150 mA, 30 VDC / 250 VAC
L	Maxx-Guard, SPST, LED, 150 mA, 30 VDC / 250 VAC
G	Maxx-Guard, SPDT, 300 mA, 24 VDC; 200 mA, 125 VAC
H	Maxx-Guard, SPDT, 3 A, 250 VAC; 2.0 W min, 100 W max
S	Maxx-Guard, SPDT, LED, 300 mA, 250 VAC
	<b>Mechanical Micro Switches</b> Temperature range -40...+80 °C / -40...+176 °F.
V	V3L-389; 10 A - 250 V AC, 0.5 A - 125 V DC
W	V3L-507-D8; gold plated contacts, 0.5 A - 30 V DC, 1 A - 125 V AC.
14	ITW/Licon; 22-104;DPDT, 4.5 A - 250 V AC, 2 switches
	<b>Valve Communication Terminal (VCT), 2 switches</b> Temperature range -40...+80 °C / -40...+176 °F.
93	FOUNDATION fieldbus VCT, bus powered. Physical layer according to IEC 61158-2.
94	FOUNDATION fieldbus VCT, externally powered. Physical layer according to IEC 61158-2.
96	AS-Interface VCT
97	AS-Interface VCT, Extended addressing

4. sign	ENCLOSURE
	Standard IP67 (4, 4X & 6) enclosure. Cover height depends on the 2. sign (see p.4 for details).
	<b>Aluminum Cover</b> Epoxy coated anodized aluminum
K	Applicable to 1. sign "QX" or "QN" with ATEX certifications
B	Applicable to 1. sign "QX" or "QN" with FM/cFM certifications
G	Applicable to 1. sign "QX" with Brazilian Inmetro certification
	<b>Clear Cover</b> Lexan® polycarbonate
A	Applicable to 1. sign "QN" with ATEX certification or without any certificates
P	Applicable to 1. sign "QN" with FM/cFM certification or 1.sign "QG"

5. sign	CONDUIT ENTRY
02	1 pcs 3/4" NPT and 1 pcs 1/2" NPT Applicable to all enclosure options, 4.sign
03	1 pcs 3/4" NPT and 2 pcs 1/2" NPT Applicable to all enclosure options, 4.sign
05	2 pcs M20x1.5 Not applicable to 4.sign "B" or "P" when 1. sign is "QX" or "QN"
06	3 pcs M20x1.5 Not applicable to 4.sign "B" or "P" when 1. sign is "QX" or "QN"

6. sign	SHAFT
H	Attachment face according to standard VDI/VDE 3845, equipped with an H-clip.
S	Attachment face according to standard VDI/VDE 3845, equipped with Namur coupler. Note: Recommended for icing conditions.

7. sign	INDICATOR
D	Red-Closed Green-Open

8. sign	LABEL
M	Metso

Subject to change without prior notice.

**Metso Automation Inc.**

**Europe**, Vanha Porvoontie 229, P.O. Box 304, FI-01301 VANTAA, Finland.

Tel. +358 20 483 150. Fax +358 20 483 151

**North America**, 44 Bowditch Drive, P.O. Box 8044, Shrewsbury, MA 01545, USA.

Tel. +1 508 852 0200. Fax +1 508 852 8172

**South America**, Av. Independência, 2500- Iporanga, 18087-101, Sorocaba-São Paulo, Brazil.

Tel. +55 15 2102 9700. Fax +55 15 2102 9748/49

**Asia Pacific**, 20 Kallang Avenue, Lobby B, #06-00, PICO Creative Centre, Singapore 339411, Singapore.

Tel. +65 6511 1011. Fax +65 6250 0830

**China**, 19/F, the Exchange Beijing, No. 118, Jianguo Lu Yi, Chaoyang Dist, 100022 Beijing, China.

Tel. +86-10-6566-6600. Fax +86-10-6566-2575

**Middle East**, Roundabout 8, Unit AB-07, P.O. Box 17175, Jebel Ali Freezone, Dubai,

United Arab Emirates. Tel. +971 4 883 6974. Fax +971 4 883 6836

[www.metso.com/valves](http://www.metso.com/valves)

