

TITLE TO AND OWNERSHIP OF THIS ENGINEERING DATA REMAINS IN MUELLER Co. NO USE IS TO BE MADE OF THIS DATA EXCEPT AS SPECIFICALLY AUTHORIZED BY MUELLER Co. ASSENT ON THE PART OF THE RECIPIENT TO THESE CONDITIONS IS PRESUMED.

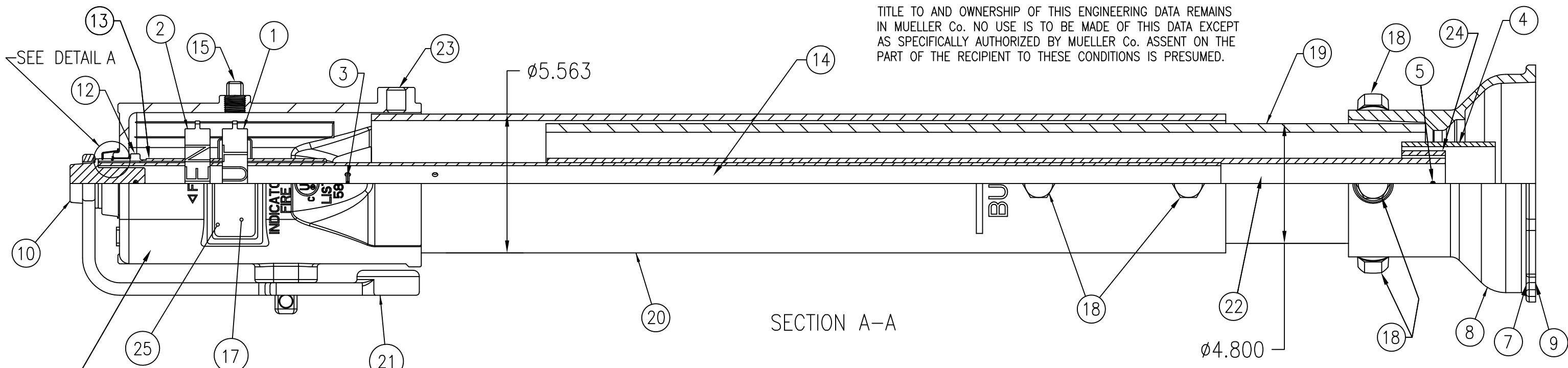

UL 789 LISTED AND FM 1110 APPROVED.

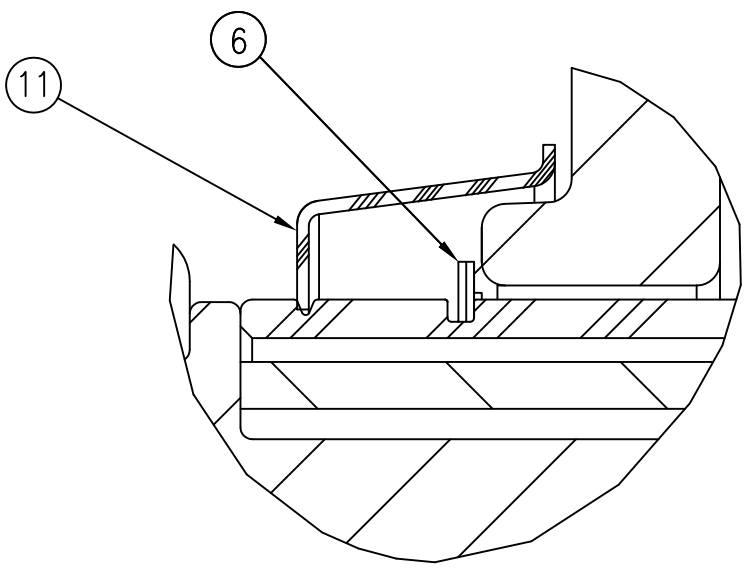

DETAIL A  
SCALE 4.000

**POST INDICATOR PAINT SPEC:**  
**WRENCH:** One coat of black primer .5-1.5 mils from the HMC Dip Line and one coat of Polane SP (Mueller Red) 2-3 mils.  
**CENTER BARREL/UPPER BARREL:** One coat of neutral orange primer 2-3 mils and one coat of Polane SP (Mueller Red) 2-3 mils.  
**BELL:** One coat of black primer .5-1.5 mils from HMC Dip Line.  
**POST HEAD & COVER:** One coat of black primer .5-1.5 mils from the HMC Dip Line all surfaces inside and out and one coat of Polane SP (Mueller Red) 2-3 mils on exterior.

ITEM No.	PART NO.	CAT. PART NO.	DESCRIPTION	MATERIAL	MATERIAL STANDARD
1	290145	P206	SHUT TARGET	PLASTIC	ZYTEL
2	290144	P209	OPEN TARGET	PLASTIC	ZYTEL
3	290154	P217	COTTER PIN (SHORT)	BRASS	ASTM B21
4	290155	P218	COUPLING	STEEL	ASTM A500 GR.B
5	290154	P219	COTTER PIN (LONG)	BRASS	ASTM B21
6	290157	P242	RETAINING RING	STAINLESS STEEL	AISI 302
7	290191	P244	HEX BOLT	STEEL/ZINC PLATED	ASTM A307 GR.A
8	148689	P273	BELL	CAST IRON	ASTM A126 CL.B
9	190939	P303	HEX NUT	STEEL/ZINC PLATED	ASTM A563 GR.A
10	148691-1	P304	OPERATING NUT	DUCTILE IRON	ASTM A536 GR.65-45-12
11	290143	P305	CAP	POLYPROPYLENE	
12	190330	P307	SPRING PIN	STAINLESS STEEL	AISI 420
13	148634	P308	THREADED SLEEVE	PLASTIC	ZYTEL
14	148633	P309	UPPER STEM	STEEL	ASTM A513
15	198582	P315	PIPE PLUG - HEX SOCKET	STEEL	
16	148692	P316	POST HEAD	CAST IRON	ASTM A126 CL.B
17	148790	P317	WINDOW	MOLDED PLASTIC	
18	190560	P322	HEX HEAD SCREW	STEEL/ZINC PLATED	ASTM A307 GR.A
19	148760	P323	LOWER BARREL	PVC	DR14 UL LISTED
20	147307	P324	UPPER BARREL	STEEL	ASTM A53 GR.B
21	148690-1	P325	WRENCH	DUCTILE IRON	ASTM A536 GR. 5-45-12
22	290137	P326	LOWER STEM	STEEL	ASTM A500 GR.B
23	198428	P329	SOCKET HEAD SET SCREW	STEEL	ANSI B18.3
24	290156	P350	COUPLING INSERT	STEEL	ASTM A500 GR.B
25	290164	P352	SHIPPING DISC *	PRESS BOARD	

\* ITEMS NOT SHOWN

DWG. No. A20806

REV.	DESCRIPTION	REF.	DRFT'R	CHK'R	APP	DATE
E	REVISED PAINT SPEC TO ERS-0075		ANC			6-24-14
D	REMOVED NOTE		MRG			6-22-12
C	ADD PART NUMBERS TO CHART		ANC			7-22-11
B	ADD PAINT SPEC		ANC			7-12-11
A	REMOVE ITEM #26		ANC			6-24-11

CATALOG NUMBER  
A20806-1044LWA SHOWN

(MILLIMETER) INCH INITIAL RELEASE DRFT'R SMC 9/26/03 CHK'R APP JMG 9/26/03 E.O. NUMBER	<b>TOLERANCES - MACHINING</b> UNLESS OTHERWISE NOTED BREAK EDGES MACH. .006/.016 FINISH SURFACES 125		THIRD ANGLE PROJECTION 	
	FRACTIONS ±1/64 DECIMALS 2 PL ±.025 3 PL ±.010 ANGLES ±1°	PURCH. FINISH REF. NO. SCALE 1:4 STK. NO.	MAT'L. DESCR. VERTICAL ADJUSTABLE INDICATOR POST ASSEMBLY WITH PVC LOWER BARREL REVISION E NUMBER A20806 SHEET 1 OF 1	