

SPECIFICATIONS

FIGURE 7873

STRUT ACCESSORIES

FNW[®]

RIGID STRUT CLAMP

Rigid Strut Clamps are used to attach rigid pipe or conduit to strut channel assemblies. They are pre-assembled and stocked with an electro-galvanized finish.

FEATURES

- For use on 2-1/2"–4" EMT conduit
- Available in 1/4"–12"
- Made in the USA

PRODUCT SPECIFICATIONS

Material

- Carbon steel – ASTM A1011-00 SS GR 33 or ASTM A1011-00CS Type B

Finish

- *Z – Electro-galvanized (standard finish). Electroplating deposits zinc on the surface of the steel by electrolysis from a bath of zinc salts. Recommended for relatively dry indoor use. This is the standard coating for most FNW products. Thickness of applied zinc is between 0.2 mils to 0.5 mils [5.1 μm to 12.7 μm]. Coatings on FNW Z products meet ASTM B633 SC1 Type III.
- AL – Aluminum – ASTM B209 (Type 5052-H32)
- *HD – Hot dip galvanized after fabrication. Fabricated product is dipped in molten zinc and is completely covered on all surfaces. Recommended for outdoor use. Coatings on FNW HD products meet ASTM A123/153. The zinc coating is typically 2.6 mils [66.0 μm] or 1.5 oz. per square foot [0.46 kg per square meter] per side.
- *S4 – 304 Stainless steel – ASTM A240 (Type 304)
- *S6 – 316 Stainless steel – ASTM A240 (Type 316)
316 Stainless steel nuts – ASTM A276-03
- Y – Yellow zinc dichromate. A 0.5 mil [12.7 μm] electro-galvanized zinc plating meeting ASTM B633 SC1 Type III is applied to the surface of the metal. Yellow dichromate is applied over the zinc. This results in a yellowish-gold appearance and acts as a nonporous barrier sealant that is corrosion resistant and can be painted.

*All Z parts supplied with Z nut and bolt.

*All HD and S4 parts supplied with 304 stainless steel nut and bolt.

*All S6 parts supplied with 316 stainless steel nut and bolt.



MADE IN THE
USA

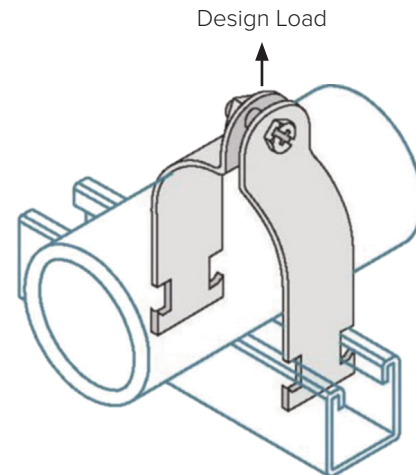

SPECIFICATIONS

FIGURE 7873
STRUT ACCESSORIES



RIGID STRUT CLAMP

REFERENCE CHART

Catalog Number	Pipe Sizes		O.D.		Design Load		Weight	
	in.	mm	in.	mm	lbs	kN	lbs	kg
FNW7873Z0025	1/4	6	0.540	14	400	1.78	0.09	0.041
FNW7873Z0037	3/8	10	0.675	17	400	1.78	0.09	0.041
FNW7873Z0050	1/2	13	0.840	21	400	1.78	0.10	0.045
FNW7873Z0075	3/4	19	1.050	27	600	2.67	0.13	0.059
FNW7873Z0100	1	25	1.315	33	600	2.67	0.15	0.068
FNW7873Z0125	1-1/4	32	1.660	42	600	2.67	0.17	0.077
FNW7873Z0150	1-1/2	38	1.900	48	800	3.56	0.29	0.132
FNW7873Z0200	2	51	2.375	60	800	3.56	0.33	0.150
FNW7873Z0250	2-1/2	64	2.875	73	800	3.56	0.39	0.177
FNW7873Z0300	3	76	3.500	89	800	3.56	0.43	0.195
FNW7873Z0350	3-1/2	90	4.000	102	1000	4.45	0.57	0.259
FNW7873Z0400	4	102	4.500	114	1000	4.45	0.62	0.281
FNW7873Z0500	5	127	5.562	141	1000	4.45	0.73	0.331
FNW7873Z0600	6	152	6.625	168	1000	4.45	0.85	0.386
FNW7873Z0800	8	203	8.625	219	1000	4.45	1.07	0.485
FNW7873Z1000	10	254	10.750	273	1000	4.45	1.27	0.576
FNW7873Z1200	12	305	12.750	324	1000	4.45	1.49	0.676