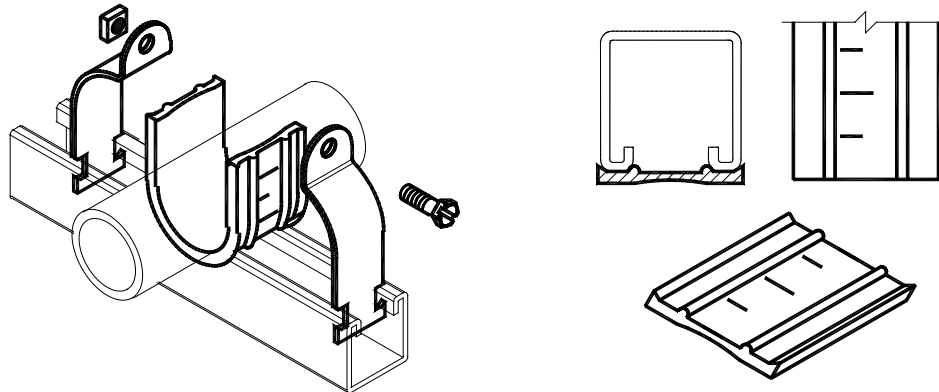

**FIGURE 7862 - Pipe Wrap**



Sold in 25 Foot Rolls

Catalog Number: FNW7862EP25

**Recommended clamp size and cut length for common pipe and tubing.**

**Iron Pipe or Rigid Conduit**

Nominal Pipe Size		PW Cut Length		Clamp Number	Qty Per Roll*
in.	Metric	in.	mm		
3/8	10	2-1/8	54.0	FNW7871Z0075	141
1/2	15	2-5/8	66.7	FNW7873Z0075	114
3/4	20	3-1/4	82.6	FNW7872Z0125	92
1	25	4-1/8	104.8	FNW7871Z0125	72
1-1/4	32	5-3/16	131.8	FNW7873Z0150	57
1-1/2	40	5-15/16	150.8	FNW7872Z0212	50
2	50	7-7/16	188.9	FNW7872Z0262	40
2-1/2	65	9	228.6	FNW7872Z0312	33
3	80	11	279.4	FNW7872Z0375	27
3-1/2	90	12-1/2	317.5	FNW7872Z0425	24
4	100	14-1/8	358.8	FNW7872Z0475	21
5	125	17-7/16	442.9	FNW7872Z0575	17
6	150	20-3/4	527.1	FNW7872Z0687	14

**Thin Wall (EMT) Conduit**

Nominal Pipe Size		PW Cut Length		Clamp Number	Qty Per Roll*
in.	Metric	in.	mm		
3/8	10	1-13/16	46.0	FNW7872Z0075	165
1/2	15	2-3/16	55.6	FNW7871Z0075	137
3/4	20	2-7/8	73.0	FNW7871Z0100	104
1	25	3-5/8	92.1	FNW7872Z0137	82
1-1/4	32	4-11/16	119.1	FNW7872Z0187	64
1-1/2	40	5-7/16	138.1	FNW7873Z0150	55
2	50	6-7/8	174.6	FNW7873Z0200	43

**Copper Tubing**

Nominal Pipe Size		PW Cut Length		Clamp Number	Qty Per Roll*
in.	Metric	in.	mm		
1/4	6	1-1/8	28.6	FNW7872Z0062	266
3/8	10	1-9/16	39.7	FNW7872Z0075	192
1/2	15	1-7/8	47.6	FNW7872Z0087	160
5/8	17	2-5/16	58.7	FNW7872Z0100	129
3/4	20	2-3/4	69.9	FNW7872Z0112	109
1	25	3-1/2	88.9	FNW7872Z0137	85
1-1/4	32	4-5/16	109.5	FNW7872Z0162	69
1-1/2	40	5-1/16	128.6	FNW7872Z0187	59
2	50	6-11/16	169.9	FNW7873Z0200	44
2-1/2	65	8-1/4	209.6	FNW7873Z0250	36
3	80	9-13/16	249.2	FNW7872Z0337	30
3-1/2	90	11-3/8	288.9	FNW7872Z0387	26
4	100	12-15/16	328.6	FNW7872Z0437	23
5	125	16-1/16	408.0	FNW7872Z0537	18
6	150	19-1/4	488.9	FNW7872Z0637	15
8	200	25-1/2	647.7	FNW7872Z0837	11

\* Quantity per roll is an approximation based on the cut length specified from a 25 foot roll.

**Wrap Information**

Material: EPDM

Temperature Range: -50°F to 360°F

Hardness Shore "A": 70 avg. (per ASTM D-2240)