

SPECIFICATIONS

FIGURE 7820 STRUT ACCESSORIES



CHANNEL NUT NO SPRING (THICK)

FNW Channel Nuts feature serrated grooves that fit onto the strut channels, securing threaded rod and other hardware to strut.

FEATURES

- Comes stock with an electro-galvanized finish (see other available finishes below).
- Cannot be used on 13/16" or 1" channel.



PRODUCT SPECIFICATIONS

Material Specifications and Finishes

Carbon steel – ASTM A1011-00 SS GR 33 or ASTM A1011-00CS Type B

- **Z:** Electro-Galvanized (standard finish). Electroplating deposits zinc on the surface of the steel by electrolysis from a bath of zinc salts. Recommended for relatively dry indoor use. This is the standard coating for most FNW products. Thickness of applied zinc is between 0.2 mils to 0.5 mils [5.1 µm to 12.7 µm]. Coatings on FNW Z products meet ASTM B633 SC1 Type III.
- **HD:** Hot Dip Galvanized After Fabrication. Fabricated product is dipped in molten zinc and is completely covered on all surfaces. Recommended for outdoor use. Coatings on FNW HD products meet ASTM A123/153. The zinc coating is typically 2.6 mils [66.0 µm] or 1.5 oz. per square foot [0.46 kg per square meter] per side.
- **S6:** 316 Stainless steel – ASTM A240 (Type 316)
316 Stainless steel nuts – ASTM A276-03

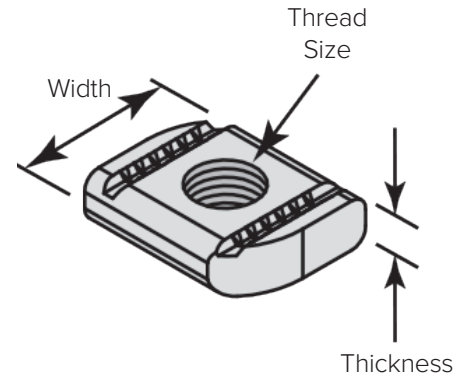

REFERENCE CHART

Catalog Number	Thread Size		Thickness		Width		Weight	
	in.	mm	in.	mm	in.	mm	lbs	kg
FNW7820Z0050	1/2	12	0.50	13	0.75	19	0.108	0.049
FNW7820Z0062	5/8	16	0.50	13	1.13	29	0.130	0.059
FNW7820Z0075	3/4	19	0.50	13	1.13	29	0.127	0.058
FNW7820Z0087	7/8	22	0.50	13	1.13	29	0.125	0.057