

## SPECIFICATIONS

# FNW7840

## STRUT ACCESSORIES



### 2-HOLE NO-TWIST CORNER ANGLE

#### FEATURES

- The FNW 7840 2-hole no-twist corner angle fitting is used to secure two pieces of unistrut channel perpendicularly. The built-in notches fit the channel groove and eliminate twisting of the fitting.
- Material is 1-5/8" [41.3] wide x 1/4" [6.3] thick unless specified.
- Holes are 9/16" [14.3] diameter 13/16" [20.6] center to edge on 1-7/8" [47.6] centers unless specified.
- Made in the USA

#### PRODUCT SPECIFICATIONS

##### Material

- Carbon steel – ASTM A1011-00 SS GR 33 or ASTM A1011-00CS Type B

##### Finish

- Z – Electro-Galvanized (standard finish). Electroplating deposits zinc on the surface of the steel by electrolysis from a bath of zinc salts. Recommended for relatively dry indoor use.
- G – GN – Green Powder Coat. A polyester powder coating is electrostatically applied after fabrication. The powder is then baked on creating a 1.38 to 1.77 mil [35–45 µm] thick coating. The hardness of this coating meets ASTM D-3363-74, the impact rating meets ASTM D-2794-93 and the gloss meets ASTM D-523-85. This creates a coating that is resistant to chipping, peeling and corrosion. Available in many colors by special order.
- HD – Hot Dip Galvanized After Fabrication. Fabricated product is dipped in molten zinc and is completely covered on all surfaces. Recommended for outdoor use. Coatings on FNW HD products meet ASTM A123/153. The zinc coating is typically 2.6 mils [66.0 µm] or 1.5 oz. per square foot [0.46 kg per square meter] per side.
- S4 – 304 Stainless steel – ASTM A240 (Type 304)
- S6 – 316 Stainless steel – ASTM A240 (Type 316)  
316 Stainless steel nuts – ASTM A276-03
- Y – Yellow zinc dichromate. A 0.5 mil [12.7 µm] electro-galvanized zinc plating meeting ASTM B633 SC1 Type III is applied to the surface of the metal. Yellow dichromate is applied over the zinc. This results in a yellowish gold appearance and acts as a nonporous barrier sealant that is corrosion resistant and can be painted.



MADE IN THE  
**USA**

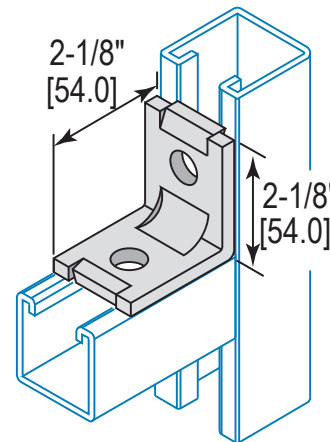

#### REFERENCE CHART

Catalog Number	Weight		Length		Width	
	lbs	kg	in.	mm	in.	mm
FNW7840Z2	0.36	0.163	2-1/8	54	2-1/8	54