



*Weksler® Pressure and
Temperature Instruments
Full Line Catalog*



TABLE OF CONTENTS

	PAGE		PAGE
Selecting A Pressure Gauge.....	4	BIMETAL THERMOMETERS	
Corrosion Chart.....	5	Introduction	53
TEST GAUGES		Adjustable Angle AFCF	54
±0.25% Accuracy (TG)	6	3" Dial Size – Rigid Forms 3A, 3S	55
General Purpose Digital Gauges (DG)	7	5" Dial Size – Rigid Forms 5A, 5S	56
ROYAL & REGAL GAUGES		3" Dial Size – Heavy Duty H3A, H3S.....	57
Process Gauges AA	11-13	Pocket Bimetal IR, 2R, 2T	58
Receiver Gauges AR	14	Sanitary Wells, Conversion Kit, Duct Flange .	59
Industrial Gauges BA	15-17	Thermowells	60-63
Altitude Gauges BM, BN	18	GLASS THERMOMETERS	
Refrigeration & Ammonia Gauges BP, BQ.....	19	Adjustable Glass Thermometers	
100mm Gauges BA4CY.....	20	A735, A935	67
Duplex Gauges BB	21	Adjustable Air Duct Thermometers	
Differential Gauges BC, BD	22	D735, D790.....	68
Reid Vapor Test RV	23	Adjust Angle Digital Thermometers	
Bellows Gauges BL	24	AD35, AD60	69
Metric Scales	25	Dimensions, Thermowells	70
Case Style & Dimensions	26-29	Navy/Marine Thermometers	
GAUGE ACCESSORIES		S520, S540	71
Accessories/Options/Tools.....	33-35	Economy Glass Thermometers E520L	71
Snubbers	36	GAS ACTUATED THERMOMETERS	
Gauge Cocks, Needle Valves, Siphons	37	Introduction	75
ECONOMY UTILITY GAUGES		Remote Mounted Thermometers	
Dry Gauges	43	313B,413B, 613B	76
Liquid Filled Gauges.....	44-46	How to Order Remote Gas Actuated	
Contractor Gauges	48	Thermometers	77-78
LINE ASSEMBLIES		Econo Gas Actuated Thermometers	
1115A/1115P Line Assemblies	49	313E, 413E, 613E.....	79
		How to Order Econo Gas Actuated	
		Thermometers	80-81
		Case Styles, Materials, Descriptions,	
		Dimensions.....	82-85
		Optional Features	86
		Thermowells	87
		Bulb Fittings.....	88
		Temperature Conversion Table.....	89

RANGE

The maximum operating pressure should not exceed 75% of the full-scale range. The normal operating range should be in the middle half of the range (between 25% and 75% of the full-scale range); whenever possible.

DIAL SIZE

Select a dial size that allows you to comfortably read the dial from the normal distance when installed.

PRESSURE SYSTEM MATERIAL

The media to which the gauge will be subjected is critical to the selection of the proper material for the Bourdon tube, bellows, and socket. Consult "corrosion chart" on page 5 for proper selection of pressure system materials. Weksler models are offered with:

- Phosphor bronze Bourdon tube (or bellows) with brass sockets.
- 316 stainless steel Bourdon tube (or bellows) with 316 stainless steel sockets.
- 316 stainless steel Bourdon tube with alloy steel sockets.
- Monel Bourdon tubes with Monel sockets.

For applications where the above materials may not be suitable, a diaphragm seal will be necessary to protect the pressure gauge system.

ACCURACY

Select a gauge with the desired accuracy as follows:

- 1/4% – test gauges only (not for in-line service)
- 1/2% – Weksler Royal gauges (4 1/2" dial size and larger) and Weksler digital gauges (2 1/2" case size)
- 1% – Weksler Regal gauges, 100 MM Gauge, EA14 gauge
- 2-1-2% – Weksler duplex, differential and low pressure gauges
- 3-2-3% – Weksler BY12, BY42, UA15, UA20, UA25, UA35 series utility gauges

MOVEMENT

Select either a gauge with 300 series stainless steel movement for long wear or a gauge with bronze or brass movement for applications where vibration and pulsation are not present.

CASE

A wide variety of case styles and materials are offered. Determine how the gauge is to be mounted: direct, surface (wall) or flush (in panel). Determine the desired case materials: polypropylene (or phenol); aluminum (black enameled) or stainless steel (300 series).

Determine case type:

Safety
(solid front with blow-out back)

Standard
(open front with rubber blow-out disc at rear)

Note – All safety case styles are designated by a number. Standard case styles are designated by a letter.

WINDOW

A glass face is standard in most gauges. If breakage is a concern, a plastic or shatterproof glass face is optional at extra cost on most Weksler Royal and Regal gauges. (Glycerin filled and sanitary gauges have plastic face as standard).

POINTER

All Weksler gauges (except utility types) have adjustable pointers. This permits pointer repositioning during calibration check or allows maximum precision at a specific point.

TEMPERATURE

The ambient temperature to which the gauge will be subjected should not exceed 150°F. If higher temperatures are encountered the gauge must be isolated from the source of heat. The temperature of the media to which the gauge is subjected to is also critical. Gauges with phosphor bronze Bourdon tubes should not be subjected to process temperatures in excess of 150°F. Gauges with metal cases and either 316 stainless steel or monel bourdons can withstand higher process temperatures, but as temperature exceeds 150°F hardening of the gasketing and discoloration of the dial may occur. In addition, accuracy will be affected by approximately 1.5% per 100°F. Both 316 stainless steel and monel gauges in metal cases will withstand 750°F for short periods of time without rupture, but other parts of the gauge will be destroyed and calibration will be lost.

VIBRATION

If present, a glycerin filled gauge is recommended.

PULSATION

If present, a pressure snubber or throttle screw is recommended.

WARNING: Misuse, Including Excessive Pressure, Vibration, Pulsation, Temperature And Corrosion May Cause Failure That Can Result in Damage Or Injury. We suggest that users of Pressure Gauges refer to American National Standard ASME B40.1 entitled "Gauges, Pressure And Vacuum Indicating Dial Type – Elastic Element" for guidance in Gauge selection. This document may be obtained from American Society of Mechanical Engineers (ASME) United Engineering Center, 345 East 47th Street, New York, N.Y. 10017.

The primary considerations in specifying or purchasing a pressure gauge are the accuracy required and the media to be used in its application. This corrosion chart has been prepared to assist you in the selection of the gauge material that is best for your installation requirement.

The media being measured must be compatible with the wetted parts of the pressure instrument. To use the chart below, locate the media whose pressure is to be measured and select a suitable material from those available. This is a simplified chart and assumes the media temperature is below 200°F except for media with an * which must be below 100°F. Throttling devices and/or a liquid filled

instrument are recommended in applications with pulsation or vibration. These recommendations are only a guide, as service life is dependent on temperature, concentrations, catalysts that may be added, or other conditions beyond our control. Consult customer service for specific applications and for any media not listed.

MEDIA APPLICATION	Pressure Instrument Material				
	Brass or bronze	Steel	316 SS	Monel	Diaphragm seals**
Acetone*	•		•	•	
Acetic Acid <40%			•		
Acetic Anhydride					•
Acetylene (Dry)		•	•		
Acrolein 100%					•
Air	•	•	•	•	
Alcohol, Ethyl	•		•	•	
Alum. Chloride >10%					•
Alum. Sulfate 10-50%					•
Ammonia Gas (Dry)		•	•		
Ammonium Chloride <40%					•
Ammonium Nitrate <50%			•		
Ammonium Sulfate <60%					•
Aniline>99%			•		
Argon	•	•	•	•	
Beer			•		
Benzidine >99%					•
Benzene <50%			•	•	
Benzoic Acid <70%					•
Boric Acid <25%			•		
Bromine (Dry)					•
Butane	•	•	•	•	
Butyric Acid <10%					•
Calcium Chloride <80%					•
Calcium Hydroxide <50%					•
Carbon Dioxide	•	•	•	•	
Carbon Monoxide (Dry) >99%	•		•	•	
Chlorine (Dry)					•
Chlorine (Moist)					•
Chloroform (Dry)			•	•	
Chromic Acid					•
Citric Acid 10-50%			•		
Corn Oil			•		

MEDIA APPLICATION	Pressure Instrument Material				
	Brass or bronze	Steel	316 SS	Monel	Diaphragm seals**
Crude Oil (Sour)					•
Crude Oil (Sweet)			•	•	
Ethyl Acetate	•		•	•	
Ethylene Oxide >99%*	•		•	•	
Ferric Chloride <40%					•
Ferric Sulfate <10%				•	
Ferrous Chloride <30%					•
Ferrous Sulfate <50%					•
Fluorine Gas (Dry) No Air				•	
Formaldehyde <95%			•	•	
Formic Acid*					•
Freons		•	•		
Furfural <10%					•
Gasoline (Flowing)	•		•		
Glycerin >99%	•	•	•	•	
Hydrobromic Acid					•
Hydrochloric Acid					•
Hydrofluoric Acid					•
Hydrofluosilic Acid					•
Hydrogen ⁽²⁾	•		•		
Hydrogen Peroxide <50%					•
Kerosene	•	•	•	•	
Lactic Acid <70%*(2)			•		
Magnesium Chloride <40%					•
Mercury >99%			•		
Milk				•	
Naphtha >99%	•	•	•	•	
Naphthalene >99%			•	•	
Nickel Chloride >99%					•
Nitric Acid <95%*			•		
Nitrogen	•	•	•	•	
Oleic Acid	•				•
Oxalic Acid*					•

MEDIA APPLICATION	Pressure Instrument Material				
	Brass or bronze	Steel	316 SS	Monel	Diaphragm seals**
Oxygen (Gas) ⁽¹⁾	•		•	•	
Palmitic Acid >99%*			•		
Phosphoric Acid <80%*			•		
Picric Acid <10%			•		
Propane (Dry) DOT Quality	•	•	•	•	
Sea Water (Flowing)					•
Silver Nitrate <70%					•
Sodium Bicarbonate <20%			•	•	
Sodium Bisulfate <30%					•
Sodium Carbonate <40%			•	•	
Sodium Chromate <60%	•	•	•	•	
Sodium Cyanide*		•	•		
Sodium Hydroxide < 40%					•
Sodium Hypochlorite <25%					•
Sodium Phosphate, Tri <60%		•	•	•	
Sodium Silicate <50%		•	•	•	
Sodium Sulfide <50%					•
Stannous Chloride <10%					•
Steam (Use siphon)	•	•	•	•	
Stearic Acid			•		
Sulfur Dioxide (Dry) >99%					•
Sulfur Trioxide (Dry) >99%					•
Sulfuric Acid					•
Tannic Acid <80%		•	•	•	
Tartaric Acid <50%			•	•	
Tin Chloride (ous) <10%					•
Toluene >99%	•	•	•	•	
Turpentine >98%	•	•	•	•	
Water (tap)	•		•	•	
Whiskey			•		
Zinc Chloride <25%*					•
Zinc Sulphate <40%					•

(1) Monel and 316 stainless steel are acceptable for oxygen service, provided the instrument has been cleaned for service and is free from oil. Order variation X6B.

(2) Over 1000 psi-entire system must be 316 stainless steel.

*Media temperature must be below 100°F.

**Any standard Bourdon tube or bellows material may be used in conjunction with a diaphragm seal (with bellows use a Viton or Kalrez diaphragm), but the gauge selection should take into consideration the corrosive environment in which it is to operate.

Table revised June 1st, 2005

STANDARD FEATURES

Movement: Precision design, stainless steel rotary gear type. Wear-resistant, and virtually frictionless for long, accurate service.

Dial & Pointer: Mirrored dial and balanced knife-edge aluminum pointer permits reading without parallax error. Dial surface is white, with black numerals and graduations in a full 270° arc. Graduation lines are same width as the knife edge on pointer.

Dial Sizes: 4½", 6"

Connection Location: ¼ or ½ male NPT

Case: Choice of two black enameled die cast aluminum cases, solid front, safety type

Style 4: Back flanged type, bayonet ring, for surface or direct mounting. Bottom connected.

Style 6: Hinged front flush mount type, back connected.

Test Gauges are designed specifically for periodic bench testing and recalibration of production type gauges. They are also recommended for use in test cells such as on research projects, and as portable instruments for field inspectors and traveling engineers. Test gauges are not suggested for continuous duty in service installations.

STANDARD RANGES

RANGE CODE	DIAL RANGES	FIGURE INTERVALS	SMALLEST GRADUATION
PC	0/15 psi	1 psi	0.05 psi
PD	0/30 psi	2 psi	0.10 psi
PE	0/60 psi	5 psi	0.20 psi
PF	0/100 psi	5 psi	0.50 psi
PG	0/160 psi	10 psi	1.0 psi
PH	0/200 psi	10 psi	1.0 psi
PJ	0/300 psi	20 psi	1.0 psi
PK	0/400 psi	20 psi	2.0 psi

STANDARD RANGES

RANGE CODE	DIAL RANGES	FIGURE INTERVALS	SMALLEST GRADUATION
PM	600 psi	0/50 psi	2.0 psi
PO	800 psi	0/50 psi	5.0 psi
PP	1000 psi	0/50 psi	5.0 psi
PR	1500 psi	0/100 psi	5.0 psi
PS	2000 psi	0/100 psi	10.0 psi
PT	3000 psi	0/200 psi	10.0 psi
PV	5000 psi	0/500 psi	20 psi
PY	10,000 psi	0/1000 psi	50 psi

BOURDON TUBE AND SOCKET

CATALOG NO.	BOURDON TUBE & SOCKET MATERIAL	DIAL SIZE
TA14 ⁽²⁾	Phosphor Bronze	4½"
TA16 ⁽²⁾	Tube, Brass Socket	6"
TA24	K Monel Tube, and Socket	4½"
TA26		6"

NOTES:

- (1) The accuracy of measurement is influenced by the ambient temperature. The Weksler test gauge is calibrated to be accurate to within ¼ of 1% of full scale range at 77°F. (25°C). Using the gauge in ambient temperatures other than this requires the application of a correction of 0.02% of the indicated pressure for each 1°F. The correction is minus if the temperature is higher and plus if lower than 77°F.
- (2) 0/400 psi maximum range.
- (3) Refer to page 26 for case dimensions.

HOW TO ORDER

T A 1 4 4 P K 4 L W

1. Basic 4-digit Catalog No. From Table Above _____
2. Case Style "4" (Bottom Connection) or "6" (Back Connection) _____
3. Range Code From Range Tables Above _____
4. Thread Size: 4 = ¼ NPT Male (Standard); 2 = ½ NPT Male _____
5. Connection Location: L = Lower (Bottom); or R = Rear (Back) _____
6. Dial Color: W = White (Standard), B = Black (Optional) _____

General Purpose Digital Gauge Type DG42P $\pm 1/2\%$ of Span Terminal Point Accuracy

STANDARD FEATURES

The Weksler DG42P offers 0.5% of span accuracy, while the stainless steel sensor and socket make this product suitable not only for dry air applications but for other media as well.

This product offers selectable units of measure so rather than purchasing one gauge for each unit of measure required, the solution is one gauge for multiple units of measure.

The DG42P is standard with many features not offered, or offered only as options, on competitor's digital gauge products, such as peak hold and $4\frac{1}{2}$ digit display. When compared to mechanical gauges the DG42P offers overall enhanced value.

- Enhanced value versus mechanical gauges
- No-nonsense accuracy – $\pm 0.5\%$ full scale accuracy
- Easy-to-read – $4\frac{1}{2}$ digit display with $1\frac{1}{2}$ " character size, optional backlite display feature to enhance visibility
- Versatile – nine engineering units and stainless steel sensor suitable for a variety of applications
- Standard features – max.-pressure indication; ranges from vacuum to 19,999 psi, including compound
- Competitively priced and can be customized for OEM applications



PRODUCT SPECIFICATIONS

Type no.:	DG42P		
Accuracy:	$\pm 0.5\%$ of span		
Case Size:	2 $\frac{1}{2}$ "		
Case Material:	Noryl®		
Wetted Parts:	17-4 PH stainless steel sensor; 316 stainless steel socket		
Socket Size:	1/4 NPT		
Connection:	Lower		
Ranges:	Vac. thru 19,999 psi (see engineering units below for other units of measurement)		
Battery:	Two AAA alkaline batteries; approximately 1000 hours battery life		
Overpressure:	Vac.	0/3000-	
	0/1000	0/5000	0/19,999
Proof:	200%	150%	120%
Burst:	800%	300%	150%
Cycle Life:	10 ⁸ cycles 20/80% F.S. with negligible performance loss		
Vibration:	Less than $\pm 0.1\%$ F.S. effect for 0/2000 Hz at 20 g's in any axis		
Shock:	Less than $\pm 0.05\%$ F.S. effect for 100 g's, 20msec shock in any axis		
Operating Temp.:	-10°C to 60°C (14°F to 140°F)		
Storage Temp.:	-20°C to 170°C (-4°F to 158°F) (maximum temperature shift is .028% per °F from -20°F to 180°F starting at 68°F. For vacuum and 30 psi ranges the maximum temperature shift is .04%)		
Update Rate:	100ms		
Agency Approvals:	CE EN 61326 (1998); CE EN 61326 Annex A (heavy industrial)		
Packaging:	Individual carton		
Opt'l. Features:	$\pm 0.25\%$ of span accuracy; backlite; 3, 9, 12 o'clock connections; Alternate socket configurations – upon application; Customized keypad; Protective boot; Bulk packaging		

DISPLAY

Type:	LCD	
Display Digits:	4 $\frac{1}{2}$	
Display Resolution:	Full Scale Numerical Value	Display Resolution
	$\geq -15 > 0$	-XX.000
	$> 0 < 2$	X.0000
	$\geq 2 < 20$	XX.000
	$\geq 20 < 200$	XXX.00
	$\geq 200 < 2000$	XXXX.0
	$\geq 2000 < 19,999$	XXXXX
Character Height:	0.5"	
Backlight:	OFF by default	
Battery:	Four-level battery indication	

KEYBOARD FUNCTIONS

On/Off:	Manually turns unit on and off (four options: never, 5 min., 10 min., 20 min.)
Backlite (optional):	Manually turns backlite on and off (four programmable auto on/off options)
Maximum (Peak Hold):	Displays max. value when activated
Zero/Clear:	Zeros display or clears max. value when activated
Engineering Units:	psi, in.Hg, cmHg, mmHg, kPa, MPa, bar, kg/cm ² , ftH ₂ O
Field Calibration:	Zero and span

W-DG42P GAUGE DIMENSIONS

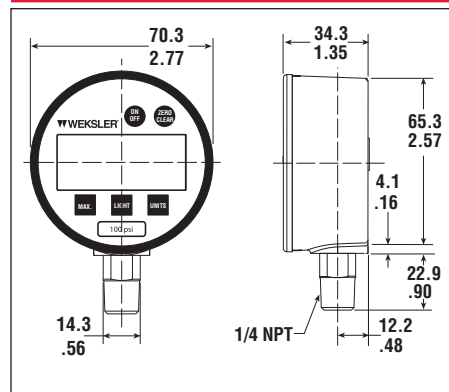

CATALOG NUMBERS

Dial Size	2 $\frac{1}{2}$ "
Connection Location	Bottom
Connection NPT	1/4
Range	
30"/vac.	W-DG42PVC4L
0-15 psi	W-DG42PPC4L
0-30 psi	W-DG42PPD4L
0-60 psi	W-DG42PPE4L
0-100 psi	W-DG42PPF4L
0-160 psi	W-DG42PPG4L
0-200 psi	W-DG42PPH4L
0-300 psi	W-DG42PPJ4L
0-600 psi	W-DG42PPM4L
0-800 psi	W-DG42PPO4L
0-1000 psi	W-DG42PPP4L
0-2000 psi	W-DG42PPS4L
0-3000 psi	W-DG42PPT4L
0-5000 psi	W-DG42PPV4L
0-10,000 psi	W-DG42PPY4L
0-15,000 psi	W-DG42PPZ4L
0-20,000 psi	W-DG42PP24L

TO ORDER SPECIFY 10 DIGIT CATALOG NUMBER FROM TABLE ABOVE

OPTION

Gauge Boot Installed	
Color	Code
Black	XB1
Orange	XB2

ROYAL & REGAL GAUGES

Process Gauges	11-13
Receiver Gauges	14
Industrial Gauges	15-17
Altitude Gauges	18
Refrigeration & Ammonia Gauges	19
100mm Gauges	20
Duplex Gauges	21
Differential Gauges	22
Special Application Gauges	23
Bellows Gauges	24
Metric Scales	25
Case Styles & Dimensions	26-29

STANDARD FEATURES

Movement: All 300 series stainless steel

Pointer: Geared micrometer adjustable, balanced

Dial: White enameled aluminum with black graduations and numerals 270° Arc

Dial Sizes: 4½"

Thread Size: ¼ male NPT; ½ male NPT

Connection Location: Lower (Bottom), Back (Rear)

Case: Standard with style #2 case; Polypropylene safety case (solid front, blow-out back) suitable for surface or direct mounting.

Bourdon Tube: 316 stainless steel

Socket: 316 stainless steel



PRESSURE RANGES

CODE NO.	DIAL RANGES	FIGURE INTERVALS	SMALLEST GRADUATION
PC	0-15 psi	1 psi	.25 psi
PD	0-30 psi	5 psi	.5 psi
PE	0-60 psi	10 psi	1 psi
PF	0-100 psi	10 psi	1 psi
PG	0-160 psi	20 psi	2 psi
PH	0-200 psi	20 psi	2 psi
PJ	0-300 psi	50 psi	5 psi
PK	0-400 psi	50 psi	5 psi
PM	0-600 psi	100 psi	10 psi
PO	0-800 psi	100 psi	10 psi
PP	0-1000 psi	100 psi	10 psi
PR	0-1500 psi	200 psi	10 psi
PS	0-2000 psi	200 psi	20 psi
PT	0-3000 psi	500 psi	20 psi
PV	0-5000 psi	500 psi	50 psi
PY	0-10,000 psi	1000 psi	100 psi
PZ	0-15,000 psi	3000 psi	100 psi
P2	0-20,000 psi	2000 psi	200 psi

VACUUM RANGES

CODE NO.	DIAL RANGES	FIGURE INTERVALS	SMALLEST GRADUATION
VC	30"-0 Hg. Vac	3"	.2"

DESCRIPTION

CATALOG NO.	GAUGE TYPE
AA44	Standard "Dry" Gauge
AS44	Hermetically Sealed "Dry" Gauge
AY44	Glycerin Filled Gauge

CASE STYLE

OPTIONAL CASE STYLE	
LOWER CONNECT	BACK CONNECT
#4 Aluminum Safety	#4 Aluminum Safety
	#6 Aluminum Flush

COMPOUND RANGES

CODE NO.	DIAL RANGES	FIGURE INTERVALS	SMALLEST GRADUATION
CA	30"-0- 15 psi	5" & 3 psi	.5"/2 psi
CB	30"-0- 30 psi	10" & 5 psi	1"/5 psi
CC	30"-0- 60 psi	10" & 10 psi	1"/1 psi
CD	30"-0-100 psi	30" & 10 psi	2"/1 psi
CE	30"-0-150 psi	30" & 20 psi	5"/2 psi
CF	30"-0-200 psi	30" & 20 psi	5"/2 psi
CG	30"-0-300 psi	30" & 50 psi	10"/5 psi
CI	30"-0-600 psi	30" & 100 psi	10"/10 psi

- NOTES:**
- Royal Gauges are calibrated in accordance with ASME B40.1 Grade 2A (±1/2%).
 - Metric dials can be furnished, see page 25.

HOW TO ORDER

A A 4 4 2 P F 4 L W ()

- Basic 4-digit Catalog No. From Table Above _____
- Polypropylene case style #2 standard or case style from above table _____
- Range Code From Range Tables Above _____
- Thread Size: 4 = ¼ Npt Male (Standard); 2 = ½ Npt Male _____
- Connection Location: L = Lower (Bottom), R = Back (Rear) _____
- Dial Color: W = White _____
- If Any Gauge Options Are Desired – Specify Option Code(s) From Page 35 _____

STANDARD FEATURES

Movement: All 300 series stainless steel
Pointer: Geared micrometer adjustable, balanced
Dial: White enameled aluminum with black graduations and numerals 270° Arc
Dial Sizes: 4½"
Thread Size: ¼ male NPT; ½ male NPT
Connection Location: Lower (Bottom), Back (Rear)
Case: Standard with style #2 case; Polypropylene safety case (solid front, blow-out back) suitable for surface or direct mounting (standard).

Bourdon Tube: Monel
Socket: Monel



PRESSURE RANGES

CODE NO.	DIAL RANGES	FIGURE INTERVALS	SMALLEST GRADUATION
PC	0-15 psi	1 psi	.25 psi
PD	0-30 psi	5 psi	.5 psi
PE	0-60 psi	10 psi	1 psi
PF	0-100 psi	10 psi	1 psi
PG	0-160 psi	20 psi	2 psi
PH	0-200 psi	20 psi	2 psi
PJ	0-300 psi	50 psi	5 psi
PK	0-400 psi	50 psi	5 psi
PM	0-600 psi	100 psi	10 psi
PO	0-800 psi	100 psi	10 psi
PP	0-1000 psi	100 psi	10 psi
PR	0-1500 psi	200 psi	10 psi
PS	0-2000 psi	200 psi	20 psi
PT	0-3000 psi	500 psi	20 psi
PV	0-5000 psi	500 psi	50 psi
PY	0-10,000 psi	1000 psi	100 psi

VACUUM RANGES

CODE NO.	DIAL RANGES	FIGURE INTERVALS	SMALLEST GRADUATION
VC	30"-0 Hg. Vac	3"	.2"

DESCRIPTION

CATALOG NO.	GAUGE TYPE
AA24	Standard "Dry" Gauge
AS24	Hermetically Sealed "Dry" Gauge
AY24	Glycerin Filled Gauge

CASE STYLE

OPTIONAL CASE STYLE	
LOWER CONNECT	BACK CONNECT
#4 Aluminum Safety	#4 Aluminum Safety
	#6 Aluminum Flush

COMPOUND RANGES

CODE NO.	DIAL RANGES	FIGURE INTERVALS	SMALLEST GRADUATION
CA	30"-0- 15 psi	5" & 3 psi	.5"/2 psi
CB	30"-0- 30 psi	10" & 5 psi	1"/.5 psi
CC	30"-0- 60 psi	10" & 10 psi	1"/1 psi
CD	30"-0-100 psi	30" & 10 psi	2"/1 psi
CE	30"-0-150 psi	30" & 20 psi	5"/2 psi
CF	30"-0-200 psi	30" & 20 psi	5"/2 psi
CG	30"-0-300 psi	30" & 50 psi	5"/2 psi
CI	30"-0-600 psi	30" & 100 psi	10"/5 psi

NOTES:
 1. Royal Gauges are calibrated in accordance with ASME B40.1 Grade 2A (±1/2%).
 2. Metric dials can be furnished, see page 25.

HOW TO ORDER

A A 2 4 2 P F 4 L W ()

1. Basic 4-digit Catalog No. From Table Above _____
2. Polypropylene case style #2 standard or case style from above table _____
3. Range Code From Range Tables Above _____
4. Thread Size: 4 = ¼ Npt Male (Standard); 2 = ½ Npt Male _____
5. Connection Location: L = Lower (Bottom), R = Back (Rear) _____
6. Dial Color: W = White _____
7. If Any Gauge Options Are Desired – Specify Option Code(s) From Page 35 _____

STANDARD FEATURES

Movement: All 300 series stainless steel

Pointer: Geared micrometer adjustable, balanced

Dial: White enameled aluminum with black graduations and numerals 270° Arc

Dial Sizes: 6", 8 1/2"

Thread Size: 1/4 male NPT; 1/2 male NPT

Connection Location: Lower (Bottom), Back (Rear)

Case: Standard with style #4 case; Aluminum safety case (solid front, blow-out back) suitable for surface or direct mounting.

Optional Case Style:

(6" size only)

Back connect #6 Aluminum Flush

Bourdon Tube: See Table Below

Socket: See Table Below



PRESSURE RANGES

CODE NO.	DIAL RANGES	FIGURE INTERVALS	SMALLEST GRADUATION
PC	0-15 psi	1 psi	.25 psi
PD	0-30 psi	5 psi	.5 psi
PE	0-60 psi	10 psi	1 psi
PF	0-100 psi	10 psi	1 psi
PG	0-160 psi	20 psi	2 psi
PH	0-200 psi	20 psi	2 psi
PJ	0-300 psi	50 psi	5 psi
PK	0-400 psi	50 psi	5 psi
PM	0-600 psi	100 psi	10 psi
PO	0-800 psi	100 psi	10 psi
PP	0-1000 psi	100 psi	10 psi
PR	0-1500 psi	200 psi	10 psi
PS	0-2000 psi	200 psi	20 psi
PT	0-3000 psi	500 psi	20 psi
PV	0-5000 psi	500 psi	50 psi
PY	0-10,000 psi	1000 psi	100 psi
PZ	0-15,000 psi	3000 psi	100 psi
P2	0-20,000 psi	2000 psi	200 psi

COMPOUND RANGES

CODE NO.	DIAL RANGES	FIGURE INTERVALS	SMALLEST GRADUATION
CA	30"-0- 15 psi	5" & 3 psi	.5"/.2 psi
CB	30"-0- 30 psi	10" & 5 psi	1"/.5 psi
CC	30"-0- 60 psi	10" & 10 psi	1"/1 psi
CD	30"-0-100 psi	30" & 10 psi	2"/1 psi
CE	30"-0-150 psi	30" & 20 psi	5"/2 psi
CF	30"-0-200 psi	30" & 20 psi	5"/2 psi
CG	30"-0-300 psi	30" & 50 psi	10"/.5 psi
CI	30"-0-600 psi	30" & 100 psi	10"/10 psi

VACUUM RANGES

CODE NO.	DIAL RANGES	FIGURE INTERVALS	SMALLEST GRADUATION
VC	30"-0 Hg. Vac	3"	.2"

BOURDON TUBE AND SOCKET

CATALOG NO.	BOURDON TUBE & SOCKET MATERIAL	DIAL SIZE	GAUGE TYPE
AA16	Brass/ Bronze	6"	Dry
AS16		6"	Herm. Seal.
AY16		6"	Liq. Fill
AA26	Monel	6"	Dry
AS26		6"	Herm. Seal.
AY26		6"	Liq. Fill
AA46	316 SS	6"	Dry
AS46		6"	Herm. Seal.
AY46		6"	Liq. Fill
AA48		8 1/2"	Dry (only)

CASE STYLES

OPTIONAL CASE STYLES
BACK CONNECT
#6 Aluminum Flush (6" Back Conn. Only)

NOTES:

- Royal Gauges are calibrated in accordance with ASME B40.1 Grade 2A (±1/2%).
- Metric dials can be furnished, see page 25.

HOW TO ORDER

A A 4 6 4 P F 4 L W ()

- Basic 4-digit Catalog No. From Table Above _____
- Aluminum case style #4 standard or case style from above table _____
- Range Code From Range Tables Above _____
- Thread Size: 4 = 1/4 Npt Male (Standard); 2 = 1/2 Npt Male _____
- Connection Location: L = Lower (Bottom), R = Back (Rear) _____
- Dial Color: W = White _____
- If Any Gauge Options Are Desired – Specify Option Code(s) From Page 35 _____

STANDARD FEATURES

Movement: All 300 series stainless steel
Pointer: Geared micrometer adjustable, balanced
Dial: White enameled aluminum with black graduations and numerals 270° Arc
Dial Sizes: 4½"
Thread Size: ¼ male NPT; ½ male NPT
Connection Location: Lower (Bottom), Back (Rear)
Case: Standard with style #2 case; Polypropylene safety case (solid front, blow-out back) suitable for surface or direct mounting (standard).

Bourdon Tube: 316 stainless steel
Socket: 316 stainless steel

Receiver gauges are used with a transmitter (transducer) to translate distant point air signals into units of pressure, temperature, liquid level or flow. Outer scale marked with equal increments of transmitted signal, inner scale graduated with units of specific measured variable (i.e.: square root, %).



AR44

STANDARD RANGES (3-15 PSI SIGNAL)			
CODE NO.	DIAL RANGES	FIGURE INTERVALS	SMALLEST GRADUATION
OC	0-100	1 psi	.25 psi
OH	0-10 Sq. Rt.	5 psi	.5 psi

BOURDON TUBE AND SOCKET			
CATALOG NO.	BOURDON TUBE & SOCKET MATERIAL	DIAL SIZE	GAUGE TYPE
AR44	316 SS	4½"	Receiver

CASE STYLES	
OPTIONAL CASE STYLE	
LOWER CONNECT	BACK CONNECT
#4 Style Alum. Safety	#6 Style Alum. Flush

- NOTES:**
 1. Royal Gauges are calibrated in accordance with ASME B40.1 Grade 2A (±1/2%).

HOW TO ORDER

A R 4 4 2 O C 4 L W ()

1. Basic 4-digit Catalog No. From Table Above _____
2. Polypropylene Case Style #2 (Standard) or case style from above table _____
3. Range Code From Range Tables Above _____
4. Thread Size: 4 = ¼ Npt Male (Standard); 2 = ½ Npt Male _____
5. Connection Location: L = Lower (Bottom), R = Back (Rear) _____
6. Dial Color: W = White _____
7. If Any Gauge Options Are Desired – Specify Option Code(s) From Page 35 _____

STANDARD FEATURES

Available in 3½" dial sizes, Regal pressure gauges are liquid fillable and field convertible for panel mounting. Both zero and span adjustments are standard. The gauge is available dry, liquid-filled weatherproof or hermetically sealed.

- Designed for safety and long life
- All stainless, all-welded construction for long life
- ASME Grade 1A, 1% accuracy full scale
- No stop pin to mask false zero reading – ensures safety and process control
- Bourdon tube, see table below
- Socket, see table below



PRESSURE RANGES			
CODE NO.	DIAL RANGES	FIGURE INTERVALS	SMALLEST GRADUATION
PC	0-15 psi	1 psi	.25 psi
PD	0-30 psi	5 psi	.5 psi
PE	0-60 psi	10 psi	1 psi
PF	0-100 psi	10 psi	1 psi
PG	0-160 psi	20 psi	2 psi
PH	0-200 psi	20 psi	2 psi
PJ	0-300 psi	50 psi	5 psi
PK	0-400 psi	50 psi	5 psi
PM	0-600 psi	100 psi	10 psi
PO	0-800 psi	100 psi	10 psi
PP	0-1000 psi	100 psi	10 psi
PR	0-1500 psi	200 psi	10 psi
PS	0-2000 psi	200 psi	20 psi
PT	0-3000 psi	500 psi	20 psi
PV	0-5000 psi	500 psi	50 psi
PY	0-10,000 psi	1000 psi	100 psi
PZ	0-15,000 psi	3000 psi	100 psi

VACUUM RANGES			
CODE NO.	DIAL RANGES	FIGURE INTERVALS	SMALLEST GRADUATION
VC	30"-0 Hg. Vac	3"	.2"

BOURDON TUBE AND SOCKET			
CATALOG NO.	BOURDON TUBE & SOCKET MATERIAL	DIAL SIZE	GAUGE TYPE
BA13	Brass/Bronze ⁽¹⁾	3½"	Dry
BS13			Herm. Sealed
BY13			Liquid Fill
BA43	316 SS		Dry
BS43			Herm. Sealed
BY43			Liquid Fill

CASE STYLES	
OPTIONAL CASE STYLE*	
LOWER CONNECT	BACK CONNECT
"X" Style SS Back Flanged	"X" Style SS
	Back Flanged
	"U" Style SS
	U-Clamp
	"V" Style SS
	Front Flanged

*See page 26 for case dimensions.

COMPOUND RANGES			
CODE NO.	DIAL RANGES	FIGURE INTERVALS	SMALLEST GRADUATION
CA	30"-0- 15 psi	5" & 3 psi	.5"/2 psi
CB	30"-0- 30 psi	10" & 5 psi	1"/5 psi
CC	30"-0- 60 psi	10" & 10 psi	1"/1 psi
CD	30"-0-100 psi	30" & 10 psi	2"/1 psi
CE	30"-0-150 psi	30" & 20 psi	5"/2 psi
CF	30"-0-200 psi	30" & 20 psi	5"/2 psi
CG	30"-0-300 psi	30" & 50 psi	10"/5 psi
CI	30"-0-600 psi	30" & 100 psi	10"/10 psi

- NOTES:**
1. Brass/Bronze maximum range is 1000 psi.
 2. Metric dials available, see page 25.

HOW TO ORDER

B A 4 3 Y P F 4 L W ()

1. Basic 4-digit Catalog No. From Table Above _____
2. Stainless Steel Case Style "Y" Standard or case style from above table _____
3. Range Code From Range Tables Above _____
4. Thread Size: 4 = ¼ Npt Male (only) _____
5. Connection Location: L = Lower (Bottom), R = Back (Rear) _____
6. Dial Color: W = White _____
7. If Any Gauge Options Are Desired – Specify Option Code(s) From Page 35 _____

STANDARD FEATURES

Movement: All 300 series stainless steel
Pointer: Geared micrometer adjustable, balanced
Dial: White enameled aluminum with black graduations and numerals 270° Arc
Dial Sizes: 4 1/2"
Thread Size: 1/4 male NPT; 1/2 male NPT
Connection Location: Lower (Bottom), Back (Rear)
Case: Polypropylene safety case #2 (solid front, blow-out back) suitable for surface or direct mounting (standard).

Bourdon Tube: Bronze
Socket: Brass



BA14

PRESSURE RANGES

CODE NO.	DIAL RANGES	FIGURE INTERVALS	SMALLEST GRADUATION
PC	0-15 psi	1 psi	.25 psi
PD	0-30 psi	5 psi	.5 psi
PE	0-60 psi	10 psi	1 psi
PF	0-100 psi	10 psi	1 psi
PG	0-160 psi	20 psi	2 psi
PH	0-200 psi	20 psi	2 psi
PJ	0-300 psi	50 psi	5 psi
PK	0-400 psi	50 psi	5 psi
PM	0-600 psi	100 psi	10 psi
PO	0-800 psi	100 psi	10 psi
PP	0-1000 psi	100 psi	10 psi

VACUUM RANGES

CODE NO.	DIAL RANGES	FIGURE INTERVALS	SMALLEST GRADUATION
VC	30"-0 Hg. Vac	3"	.2"

BOURDON TUBE AND SOCKET

CATALOG NO.	BOURDON TUBE & SOCKET MATERIAL	DIAL SIZE	GAUGE TYPE
BA14	Brass/Bronze ⁽²⁾	4 1/2"	Dry
BS14			Herm. Seal.
BY14			Liquid Fill

CASE STYLES

OPTIONAL CASE STYLE	
LOWER CONNECT	BACK CONNECT
"X" Style SS Back Flng.	"X" Style SS Back Flng.
"Y" Style SS	"U" Style SS U- Clamp
#4 Style Alum. Safety	"V" Style SS Front Flng.
	"Y" Style SS
	#4 Style Alum. Safety
	#6 Style Alum. Safety

COMPOUND RANGES

CODE NO.	DIAL RANGES	FIGURE INTERVALS	SMALLEST GRADUATION
CA	30"-0- 15 psi	5" & 3 psi	.5"/2 psi
CB	30"-0- 30 psi	10" & 5 psi	1"/5 psi
CC	30"-0- 60 psi	10" & 10 psi	1"/1 psi
CD	30"-0-100 psi	30" & 10 psi	2"/1 psi
CE	30"-0-150 psi	30" & 20 psi	5"/2 psi
CF	30"-0-200 psi	30" & 20 psi	5"/2 psi
CG	30"-0-300 psi	30" & 50 psi	10"/5 psi
CI	30"-0-600 psi	30" & 100 psi	10"/10 psi

NOTES:

1. Regal gauges are calibrated in accordance with ASME B40.1 Grade 1A (±1%).
2. Brass/Bronze maximum range is 1000 psi.

HOW TO ORDER

B A 1 4 2 P F 4 L W ()

1. Basic 4-digit Catalog No. from Table Above _____
2. Polypropylene Case Style #2 (Standard) or choose from above table _____
3. Range Code From Range Tables Above _____
4. Thread Size: 4 = 1/4 Npt Male (Standard); 2 = 1/2 Npt Male _____
5. Connection Location: L = Lower (Bottom), R = Back (Rear) _____
6. Dial Color: W = White _____
7. If Any Gauge Options Are Desired – Specify Option Code(s) From Page 35 _____

STANDARD FEATURES

Movement: All 300 series stainless steel
Pointer: Geared micrometer adjustable, balanced
Dial: White enameled aluminum with black graduations and numerals 270° Arc
Dial Sizes: 6", 8½", 12"
Thread Size: ¼ male NPT; ½ male NPT
Connection Location: Lower (Bottom), Back (Rear)⁽³⁾
Case: 6", 8½" Aluminum safety case (solid front, blow-out back) suitable for surface or direct mounting (4 Style).

12" Aluminum (open front)
 Back Flanged: (E style)
Bourdon Tube: See table below
Socket: See table below



PRESSURE RANGES

CODE NO.	DIAL RANGES	FIGURE INTERVALS	SMALLEST GRADUATION
PC	0-15 psi	1 psi	.25 psi
PD	0-30 psi	5 psi	.5 psi
PE	0-60 psi	10 psi	1 psi
PF	0-100 psi	10 psi	1 psi
PG	0-160 psi	20 psi	2 psi
PH	0-200 psi	20 psi	2 psi
PJ	0-300 psi	50 psi	5 psi
PK	0-400 psi	50 psi	5 psi
PM	0-600 psi	100 psi	10 psi
PO	0-800 psi	100 psi	10 psi
PP	0-1000 psi	100 psi	10 psi
PR	0-1500 psi	200 psi	10 psi
PS	0-2000 psi	200 psi	20 psi
PT	0-3000 psi	500 psi	20 psi
PV	0-5000 psi	500 psi	50 psi
PY	0-10,000 psi	1000 psi	100 psi
PZ	0-15,000 psi	3000 psi	100 psi
P2	0-20,000 psi	2000 psi	200 psi

VACUUM RANGES

CODE NO.	DIAL RANGES	FIGURE INTERVALS	SMALLEST GRADUATION
VC	30"~0 Hg. Vac	3"	.2"

BOURDON TUBE AND SOCKET

CATALOG NO.	BOURDON TUBE & SOCKET MATERIAL	DIAL SIZE	GAUGE TYPE
BA16	Brass/Bronze ⁽⁴⁾	6"	Dry
BS16			Herm. Seal.
BY16			Liq. Fill
BA18	Brass/Bronze ⁽⁴⁾	8½"	Dry
BA49	316 SS	12"	Dry

CASE STYLES

OPTIONAL CASE STYLE	
LOWER CONNECT	BACK CONNECT
#4 Style Alum. Safety (only)	#6 Style Alum. Flush
#4 Style Alum. Safety (only)	#4 Style Alum. Safety (only)
"E" Style Alum. Safety Back Flanged	Not Available in Back Connect

COMPOUND RANGES

CODE NO.	DIAL RANGES	FIGURE INTERVALS	SMALLEST GRADUATION
CA	30"~0- 15 psi	5" & 3 psi	.5"~.2 psi
CB	30"~0- 30 psi	10" & 5 psi	1"~.5 psi
CC	30"~0- 60 psi	10" & 10 psi	1"~1 psi
CD	30"~0-100 psi	30" & 10 psi	2"~1 psi
CE	30"~0-150 psi	30" & 20 psi	5"~2 psi
CF	30"~0-200 psi	30" & 20 psi	5"~2 psi
CG	30"~0-300 psi	30" & 50 psi	10"~5 psi
CI	30"~0-600 psi	30" & 100 psi	10"~10 psi

NOTES:

1. Regal Gauges are calibrated in accordance with ASME B40.1 Grade 1A (±1%).
2. Metric dials can be furnished, see page 25.
3. 12" available in lower connect only
4. Brass/Bronze maximum range is 1000 psi.

HOW TO ORDER

B A 1 6 4 P F 4 L W ()

1. Basic 4-digit Catalog No. From Table Above _____
2. Case Style from Table Above _____
3. Range Code From Range Tables Above _____
4. Thread Size: 4 = ¼ Npt Male (Standard); 2 = ½ Npt Male _____
5. Connection Location: L = Lower (Bottom), R = Back (Rear) _____
6. Dial Color: W = White _____
7. If Any Gauge Options Are Desired – Specify Option Code(s) From Page 35 _____



**Regal Altitude Gauges
±1.0% Accuracy
316 St. St. Tube & Socket
3½" & 4½" Dial Size**

STANDARD FEATURES

Movement: All 300 series stainless steel
Pointer: Geared micrometer adjustable, balanced
Dial: White enameled aluminum with black graduations and numerals 270° Arc
Dial Sizes: 3½" (12), 4½"
Thread Size: ¼ male NPT; ½ male NPT
Connection Location: Lower (Bottom), Back (Rear)
Case: Standard with style #2 case; 4½" polypropylene safety case (solid front, blow-out back) suitable for surface or direct mounting (standard). 3½" stainless steel case ("Y" style)

Bourdon Tube: 316 St. St.
Socket: 316 St. St.



BM1 ALTITUDE RANGES

RANGE CODE	TOTAL GRADUATION	FIGURE INTERVALS	SMALLEST GRADUATION
HA	0-30 ft.	5 ft.	½ ft.
HB	0-70ft.	10 ft.	1 ft.
HC	0-100 ft.	10 ft.	1 ft.
HD	0-160 ft.	20 ft.	2 ft.
HE	0-200 ft.	20 ft.	2 ft.
HF	0-250 ft.	25 ft.	5 ft.
HG	0-300 ft.	50 ft.	5 ft.
HH	0-400 ft.	50 ft.	5 ft.
HI	0-500 ft.	50 ft.	5 ft.
HJ	0-600 ft.	100 ft.	10 ft.

BOURDON TUBE AND SOCKET

CATALOG NO.	BOURDON TUBE & SOCKET MATERIAL	DIAL SIZE	GAUGE TYPE
BM43	316 SS	3½"	Altitude (only)
BN43			Altitude & PSI equivalent
BM44	316 SS	4½"	Altitude (only)
BN44			Altitude & PSI equivalent

CASE STYLES

OPTIONAL CASE STYLE	
LOWER CONNECT	BACK CONNECT
"X" Style SS Back Flng.	"U" Style SS U-Clamp
	"V" Style SS Front Flng "X" Style SS Back Flng
#4 Style Alum. Safety	#6 Style Alum. Flush

NOTES:

- Regal Gauges are calibrated in accordance with ASME B40.1 Grade 1A (±1%).
- 3½" available in ¼ male NPT only.

BN1 ALTITUDE/PRESSURE

RANGE CODE	TOTAL GRADUATION	FIGURE INTERVALS	SMALLEST GRADUATION
HO	15 psi & 35 ft.	3 psi & 5 ft.	¼ psi & ½ ft.
HP	30 psi & 70 ft.	5 psi & 10 ft.	½ psi & 1 ft.
HQ	50 psi & 116 ft.	10 psi & 10 ft.	1 psi & 2 ft.
HW	60 psi & 140 ft.	10 psi & 20 ft.	1 psi & 2 ft.
HR	100 psi & 231 ft.	10 psi & 25 ft.	1 psi & 5 ft.
HS	150 psi & 345 ft.	20 psi & 20 ft.	2 psi & 5 ft.
HT	200 psi & 460 ft.	20 psi & 50 ft.	2 psi & 5 ft.
HU	300 psi & 690 ft.	50 psi & 50 ft.	5 psi & 10 ft.

HOW TO ORDER

B M 4 4 2 H A 4 L W ()

- Basic 4-digit Catalog No. From Table Above _____
- Polypropylene case style #2 (Standard) or choose from above table _____
- Range Code From Range Tables Above _____
- Thread Size: 4 = ¼ Npt Male (Standard); 2 = ½ Npt Male _____
- Connection Location: L = Lower (Bottom), R = Back (Rear) _____
- Dial Color: W = White _____
- If Any Gauge Options Are Desired – Specify Option Code(s) From Page 35 _____

Regal Refrigerant and Ammonia Gauges
±1.0% Accuracy
3 1/2", 4 1/2" & 6" Dial Size

STANDARD FEATURES

Movement: All 300 series stainless steel

Pointer: Geared micrometer adjustable, balanced

Dial: White enameled aluminum with black graduations and numerals 270° Arc

Dial Sizes: 3 1/2", 4 1/2", 6"

Thread Size: 1/4 male NPT; 1/2 male NPT

Connection Location: Lower (Bottom), Back (Rear)

Case: 3 1/2", "Y" Style SS
 4 1/2", #2 Polypropylene safety
 6", #4 Aluminum safety

Bourdon Tube: 316 stainless steel

Socket: 316 stainless steel

Refrigerant gauges indicate both pressure and vacuum with corresponding temperature of refrigerants.

Ammonia gauges indicate both pressure and vacuum with corresponding temperature in ammonia systems.



BOURDON TUBE AND SOCKET				CASE STYLES	
CATALOG NO.	BOURDON TUBE & SOCKET MATERIAL	DIAL SIZE	GAUGE TYPE	OPTIONAL CASE STYLE	
				LOWER CONNECT	BACK CONNECT
BP43	316 SS	3 1/2"	Ammonia	"X" Style SS Back Flng.	"U" Style SS U-Clamp
BQ43			Refrigeration		"V" Style SS Front Flng "X" Style SS Back Flng
BP44	316 SS	4 1/2"	Ammonia	#4 Style Alum. Safety	#6 Style Alum. Flush
BQ44			Refrigeration		
BP46	316 SS	6"	Ammonia	#4 Style Alum. Safety	#6 Style Alum. Flush
BQ46			Refrigeration		

BP AMMONIA GAUGE RANGES

DIAL RANGES	FIGURE INTERVALS	SMALLEST GRADUATION	RANGE CODE
30"-0-150 psi	30" & 25 psi	5" & 5 psi	AA
30"-0-300 psi	30" & 25 psi	5" & 5 psi	AB

BQ REFRIGERANT GAUGE RANGES

	R12	R22	R134A	R502
30"-0-150 psi	FH	FN	F7	F5
30"-0-300 psi	FI	FO	F8	F6
300 psi	FF	FM	-	F4

NOTES:

- Any standard pressure or compound range, from 30 to 400# can be furnished for ammonia or refrigerant use, without temperature equivalent, at no additional charge
- Figure intervals and smallest graduations above are for 4 1/2" and 6" gauges. Graduations and intervals may vary for 3 1/2" dial sizes.

HOW TO ORDER

B P 4 4 2 A B 4 L W ()

- Basic 4-digit Catalog No. From Table Above _____
- Polypropylene case style #2 (Standard) or choose from above table _____
- Range Code From Range Tables Above _____
- Thread Size: 4 = 1/4 Npt Male (Standard); 2 = 1/2 Npt Male _____
- Connection Location: L = Lower (Bottom), R = Back (Rear) _____
- Dial Color: W = White, B = Black (optional) _____
- If Any Gauge Options Are Desired – Specify Option Code(s) From Page 35 _____

STANDARD FEATURES

Movement: 300 series stainless steel

Pointer: Micrometer adjustable

Dial: White enameled aluminum

Dial Size: 100mm – dry or glycerin filled

Connection Location: 1/4 NPT or 1/2 NPT lower (bottom)

Case: Polished 304 stainless steel
Hermetically sealed

Dry version is liquid fillable in field
304 stainless steel case and bezel

Bourdon Tube & Socket: 316 stainless steel

- Suitable for a broad range of industrial applications

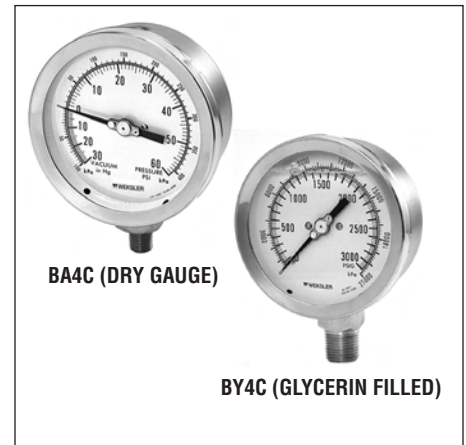
PRESSURE RANGES

SPECIFY 10 DIGIT CATALOG NUMBER FROM THE TABLE BELOW

RANGE DUAL SCALE PSI & KPA	10 DIGIT CATALOG NUMBERS			
	DRY GAUGE		Glycerin FILLED GAUGE	
	1/4 NPT	1/2 NPT	1/4 NPT	1/2 NPT
HG vac & 100-0 kPa	N/A	BA4CYVC2LW	BY4CYVC4LW	BY4CYVC2LW
30"-0-30 psi & 100-0-200 kPa	BA4CYCB4LW	BA4CYCB2LW	BY4CYCB4LW	BY4CYCB2LW
30"-0-60 psi & 100-0-400 kPa	BA4CYCC4LW	N/A	BY4CYCC4LW	BY4CYCC2LW
30"-0-150 psi & 100-0-1000 kPa	N/A	N/A	BY4CYCE4LW	BY4CYCE2LW
0-15 psi & 0-100 kPa	BA4CYPC4LW	BA4CYPC2LW	BY4CYPC4LW	BY4CYPC2LW
0-30 psi & 0-200 kPa	BA4CYPD4LW	BA4CYPD2LW	BY4CYPD4LW	BY4CYPD2LW
0-60 psi & 0-400 kPa	BA4CYPE4LW	BA4CYPE2LW	BY4CYPE4LW	BY4CYPE2LW
0-100 psi & 0-700 kPa	BA4CYPF4LW	BA4CYPF2LW	BY4CYPF4LW	BY4CYPF2LW
0-160 psi & 0-1100 kPa	BA4CYPG4LW	BA4CYPG2LW	BY4CYPG4LW	BY4CYPG2LW
0-200 psi & 0-1400 kPa	BA4CYPH4LW	BA4CYPH2LW	BY4CYPH4LW	BY4CYPH2LW
0-300 psi & 0-2100 kPa	BA4CYPJ4LW	BA4CYPJ2LW	BY4CYPJ4LW	BY4CYPJ2LW
0-600 psi & 0-4200 kPa	BA4CYPM4LW	BA4CYPM2LW	BY4CYPM4LW	BY4CYPM2LW
0-1000 psi & 0-7000 kPa	BA4CYP4LW	BA4CYP2LW	BY4CYP4LW	BY4CYP2LW
0-2000 psi & 0-14000 kPa	N/A	N/A	N/A	BY4CYP2LW
0-3000 psi & 0-21000 kPa	N/A	BA4CYPT2LW	N/A	BY4CYPT2LW
0-5000 psi & 0-35000 kPa	N/A	N/A	BY4CYPV4LW	BY4CYPV2LW
0-10,000 psi & 0-70000 kPa	N/A	BA4CYPY2LW	N/A	BY4CYPY2LW

HOW TO ORDER

1. Select 10-digit Catalog No. From Table Above

STANDARD FEATURES

Movement: Bronze

Pointer: Non-adjustable red and black pointers

Dial: White enameled aluminum with black graduations and numerals.

Dial Sizes: 4½"

Thread Size: ¼ male NPT (only)

Connection Location: Lower or Rear (back)

Case: Suitable for direct or surface mounting.

Lower – (bottom) connect available in "A" style aluminum flanged case (only).

Back – (rear) connect "A" style (standard) "W" style (optional) aluminium flush

The Weksler Type BB14A duplex gauge is used to display two separate input pressures on the same gauge for comparison puposes.



BB14A

NOTES:

1. Regal Duplex Gauges are calibrated in accordance with ASME B40.1 Grade A (±1% middle third). See page 4 of this catalog for further reference to ASME B40.1.
2. Metric dials can be furnished. See Page 25.

CATALOG NO.	BOURDON TUBE & SOCKET MATERIAL	MAXIMUM PRESSURE (psi)	DIAL SIZE (INCHES)	STANDARD CASE
BB14	Phosphor Bronze Bourdon Forged Brass Socket	1000	4½	Style "A" ⁽¹⁾ Style "W" ⁽²⁾

NOTE: BB1 series *not* available with safety cases.

1. Aluminum back flanged, bottom connection only.
2. Aluminum hinged, back connection only.

PRESSURE RANGES

CODE NO.	DIAL RANGES	FIGURE INTERVALS	SMALLEST GRADUATION
PD	0-30 psi	5 psi	.5 psi
PE	0-60 psi	10 psi	1 psi
PF	0-100 psi	10 psi	1 psi
PG	0-160 psi	20 psi	2 psi
PH	0-200 psi	20 psi	2 psi
PJ	0-300 psi	50 psi	5 psi
PK	0-400 psi	50 psi	5 psi
PM	0-600 psi	100 psi	10 psi
PO	0-800 psi	100 psi	10 psi
PP	0-1000 psi	100 psi	10 psi

COMPOUND RANGES

CODE NO.	DIAL RANGES	FIGURE INTERVALS	SMALLEST GRADUATION
CA	30"-0- 15 psi	10" & 2 & 15 psi	1"⁄5 psi
CB	30"-0- 30 psi	10" & 5 psi	1"⁄1 psi
CC	30"-0- 60 psi	10" & 10 psi	1"⁄1 psi
CD	30"-0-100 psi	30" & 10 psi	2"⁄1 psi
CE	30"-0-150 psi	30" & 25 psi	5"⁄5 psi
CF	30"-0-200 psi	30" & 20 psi	5"⁄5 psi
CG	30"-0-300 psi	30" & 50 psi	10"⁄5 psi

HOW TO ORDER

B B 1 4 A C C 4 L W ()

1. Basic 4-digit Catalog No. From Table Above _____
2. Case Style Code A for lower conn., W for back conn. _____
3. Range Code From Range Tables Above (See notation above) _____
4. Thread Size: 4 = ¼ Npt Male (only) _____
5. Connection Location: L = Lower (Bottom); or R = Rear (Back) _____
6. Dial Color: W = White (Standard), B = Black (Optional) _____
7. If Any Gauge Options Are Desired – Specify Option Code(s) From Page 35 _____

STANDARD FEATURES

Movement: Bronze

Pointer: Geared micrometer adjustable

Dial: White enameled aluminum. Black graduations and numerals

Dial Sizes: 4½", 6"

Thread Size: ¼ male NPT only

Connection Location: 4½" lower (bottom) or Back (rear) 6" lower (bottom) only

Case: Suitable for direct or surface mounting. Available in "A" style aluminum case only.

To measure the difference between two pressure sources, apply high pressure, then low pressure. Read differential pressure on the gauge. BC designed with "O" at top center, BD with "O" at the left.



BC14A

BC GAUGES RANGE TABLE

CODE NO.	DIAL RANGES	FIGURE INTERVALS	SMALLEST GRADUATION	STATIC PRESSURE LIMITS
DA	10-0- 10 psi	2 psi	0.5 psi	30 psi
DB	15-0- 15 psi	3 psi	0.2 psi	60 psi
DC	30-0- 30 psi	5 psi	1 psi	120 psi
DD	50-0- 50 psi	10 psi	1 psi	200 psi
DE	100-0-100 psi	20 psi	2 psi	300 psi
DF	200-0-200 psi	50 psi	5 psi	600 psi
DG	300-0-300 psi	100 psi	10 psi	900 psi
DH	400-0-400 psi	100 psi	10 psi	1200 psi

CATALOG NO.	BOURDON TUBE & SOCKET MATERIAL	DIAL SIZE (Inches)	STD. CASE
BC14 or BD14	Phosphor Bronze	4½	Style "A"
BC16 or BD16	Forged Brass Socket	6	Style "A"
BC44 or BD44	Stainless Steel, 316	4½	Style "A"

NOTES:

1. Regal Differential Gauges are calibrated in accordance with ASME B40.1 Grade A (±1% middle third). See page 4 of this catalog for further reference to ASME B40.1.

BD GAUGES RANGE TABLE

CODE NO.	DIAL RANGES	FIGURE INTERVALS	SMALLEST GRADUATION	STATIC PRESSURE LIMITS
PB	*0-10 psi	2 psi	¼ psi	45 psi
P5	*0-20 psi	2 psi	½ psi	30 psi
PD	0-30 psi	5 psi	½ psi	60 psi
PE	0-60 psi	10 psi	1 psi	120 psi
PF	0-100 psi	10 psi	1 psi	200 psi
PG	0-160 psi	20 psi	2 psi	300 psi
PH	0-200 psi	20 psi	2 psi	300 psi
PJ	0-300 psi	50 psi	5 psi	450 psi
PK	0-400 psi	50 psi	5 psi	600 psi
PM	0-600 psi	100 psi	10 psi	900 psi
PO	0-800 psi	100 psi	10 psi	1200 psi
PP	0-1,000 psi	100 psi	10 psi	1500 psi

*Only available with BD44, **180° dial arc

HOW TO ORDER

B C 1 6 A D D 4 L W ()

1. Basic 4-digit Catalog No. From Table Above _____
2. Case Style Code "A" (only) _____
3. Range Code From Range Tables Above (See notation above) _____
4. Thread Size: 4 = ¼ Npt Male (only) _____
5. Connection Location: L = Lower (Bottom); or R = Rear (Back) _____
6. Dial Color: W = White (Standard), B = Black (Optional) _____
7. If Any Gauge Options Are Desired – Specify Option Code(s) From Page 35 _____



**Special Application Gauge
Type RV14, ASME B 40.1
Grade 2A (±0.5% of span)
4½" Dial Size**

STANDARD FEATURES

RV14 Reid Vapor Test Gauge

The Weksler Type RV14 is a specialized pressure gauge used by the petroleum industry to measure vapor pressures of various petroleum products.

- Accuracy ASME B 40.1 Grade 2A (±0.5% of span)
- Dial Size 4½" only
- White dial and black pointer



SPECIFICATIONS

Gauge Type Number	Dial Size (Inches)	Case & Ring Material Finish	Bourdon Tube & Tip Material (all joints welded)	Socket Material	Pressure Range (psi)	Pointer	Movement	NPT Conn.
Reid Vapor Test RV14	4½	Case: Aluminum black epoxy coated	Phosphor Bronze Tip: Brass (All joints silver brazed)	Brass	15/600	Micrometer Adjustable	Stainless steel Teflon coated, pinion and sector shaft, rotary geared	¼

STANDARD RANGES

Code	Range psi	Figure Interval	Minor Graduation
PC	0/15	1	0.1
PD	0/30	2	0.2
PE	0/60	4	0.25
PF	0/100	5	0.5
PH	0/200	10	1
PI	0/250	10	1
PJ	0/300	10	1
PK	0/400	20	2
PM	0/600	20	2

HOW TO ORDER

R V 1 4 4 P C 4 L W

1. Basic 4-digit Catalog No. RV14 _____
2. Case Style Code "4" (only case available) _____
3. Range Code From Range Tables Above _____
4. Thread Size: 4 = ¼ Npt Male (only thread size available) _____
5. Connection Location: L = Lower (Bottom) _____
6. Dial Color: W = White _____

**Low Pressure Gauges –
Bellows Type
±2-1-2% Accuracy
4½" Dial Size**

STANDARD FEATURES

- Movement:** Bronze
- Pointer:** Balanced Slotted adjustable
- Dial:** White enameled aluminum. Black graduations and numerals
- Thread Size:** ¼ male NPT; ½ male NPT
- Connection Location:** Lower or Rear (back)
- Case:** Style "2" polypropylene safety suitable for direct or surface mounting.

Ideal for applications under 15 psi.



BL44

NOTES:

1. Regal Low Pressure Gauges are calibrated in accordance with ASME B40.1 Grade A (±1% middle third). See page 4 of this catalog for further reference to ASME B40.1.

RANGES FOR BELLOWS GAUGES

CODE NO.	DIAL RANGES	FIGURE INTERVALS	SMALLEST GRADUATION	DIAL ARC	
				BL1	BL4
PA	0 to 5 psi	1 psi	¼ psi	270°	270°
PB	0 to 10 psi	1 psi	½ psi	270°	270°
WR	10 to 0" Water Vac.	2"	¼"	90°	–
WS	15 to 0" Water Vac.	3"	½"	90°	–
WT	40 to 0" Water Vac. & 75 mm Hg.	5" & 10 mm	1" & 1 mm	270°	180°
VD	5 to 10" Hg. Vac.	1"	¼"	270°	270°
VA	10 to 0" Hg. Vac.	2"	¼"	270°	270°
WW	10" Water Vacuum & 10" Water Pressure	2"	½"	180°	180°
WX	20" Water Vacuum & 40" Water Pressure	10"	1"	270°	270°
WY	10" Hg. Vacuum & 5 psi Pressure	2" & 1 psi	½" & .1 psi	270°	270°
WA	0 to 10" Water Press.	1"	¼"	90°	–
WB	0 to 15" Water Press.	3"	¼"	90°	90°
WH	0 to 20" Water Press. & 12oz.	½" & 1 oz.	1" & ¼ oz.	180°	90°
WI	0 to 30" Water Press. & 18oz.	5" & 1 oz.	½" & ½ oz.	215°	–
WI	0 to 30" Water Press. & 18oz.	10" & 1 oz.	1" & ½ oz.	–	180°
WJ	0 to 40" Water Press. & 24 oz.	5" & 3 oz.	1" & ½ oz.	270°	180°
WK	0 to 60" Water Press. & 35 oz.	10" & 5 oz.	1" & 1 oz.	270°	270°
WL	0 to 80" Water Press. & 45 oz.	10" & 5 oz.	1" & 1 oz.	270°	270°
WM	0 to 100" Water Press. & 57 oz.	10" & 5 oz.	1" & 1 oz.	270°	270°

BELLOWS AND SOCKET

CATALOG NO.	BELLOWS & SOCKET MATERIAL	DIAL SIZE	GAUGE TYPE	OPTIONAL CASE STYLE	
				LOWER CONNECT	BACK CONNECT
BL14	Phsp. Brnz. Bellows Brass Socket	4½"	Low Pressure	#4 Aluminum Safety	#6 Aluminum Safety
BL44	316 SS Bellows 316 SS Socket				

HOW TO ORDER

B L 4 4 2 W K 4 L W ()

1. Basic 4-digit Catalog No. From Table Above _____
2. Polypropylene case style #2 (Standard) or choose from above table _____
3. Range Code From Range Tables Above _____
4. Thread Size: 4 = ¼ Npt Male; 2 = ½ Npt Male _____
5. Connection Location: L = Lower (Bottom); or R = Rear (Back) _____
6. Dial Color: W = White (Standard), B = Black (Optional) _____
7. If Any Gauge Options Are Desired – Specify Option Code(s) From Page 35 _____

kg/cm ²		CODE	SINGLE SCALE
MR	76-0 CMS & 30-0 VAC	E1	76-0 CMS
MZ	76 CMS/O/1 kg/cm ² & 30~-0-14 psi	EZ	76 CMS/O/1 kg/cm ²
MS	76 CMS/O/2 kg/cm ² & 30~-0-28 psi	E2	76 CMS/O/2 kg/cm ²
MT	76 CMS/O/4 kg/cm ² & 30~-0-57 psi	E3	76 CMS/O/4 kg/cm ²
MU	76 CMS/O/ 7 kg/cm ² & 30~-0-100 psi	E4	76 CMS/O/7 kg/cm ²
MV	76 CMS/O/10 kg/cm ² & 30~-0-140 psi	E5	76 CMS/O/10 kg/cm ²
MX	76 CMS/O/21 kg/cm ² & 30~-0-300 psi	E7	76 CMS/O/21 kg/cm ²
MA	0-1 kg/cm ² & 0-14 psi	EA	0-1 kg/cm ²
MB	0-2 kg/cm ² & 0-28 psi	EC	0-2 kg/cm ²
MC	0-4 kg/cm ² & 0-57 psi	EF	0-4 kg/cm ²
MD	0-7 kg/cm ² & 0-100 psi	EG	0-7 kg/cm ²
ME	0-11 kg/cm ² & 0-160 psi	EH	0-11 kg/cm ²
MF	0-14 kg/cm ² & 0-200 psi	EI	0-14 kg/cm ²
MQ	0-18 kg/cm ² & 0-250 psi	EJ	0-18 kg/cm ²
MG	0-21 kg/cm ² & 0-300 psi	EK	0-21 kg/cm ²
MH	0-28 kg/cm ² & 0-400 psi	EL	0-28 kg/cm ²
MP	0-35 kg/cm ² & 0-500 psi	EM	0-36 kg/cm ²
MI	0-42 kg/cm ² & 0-600 psi	EN	0-42 kg/cm ²
MJ	0-56 kg/cm ² & 0-800 psi	EO	0-56 kg/cm ²
MK	0-70 kg/cm ² & 0-1000 psi	EP	0-70 kg/cm ²
ML	0-105 kg/cm ² & 0-1500 psi	EQ	0-105 kg/cm ²
M2	0-140 kg/cm ² & 0-2000 psi	ER	0-140 kg/cm ²
MM	0-210 kg/cm ² & 0-3000 psi	ES	0-210 kg/cm ²
MN	0-350 kg/cm ² & 0-5000 psi	EU	0-350 kg/cm ²
MD	0-700 kg/cm ² & 0-10,000 psi	EV	0-700 kg/cm ²

kPa		CODE	SINGLE SCALE
L2	30/0 VAC & 100/0 kPa	K1	-100/0 kPa
L3	30~/0/15 psi & 100/0/100 kPa	K2	100/0/100 kPa
L4	30~/0/30 psi & 100/0/200 kPa	K3	100/0/200 kPa
L5	30~/0/60 psi & 100/0/400 kPa	K4	100/0/400 kPa
L6	30~/0/100 psi & 100/0/700 kPa	K5	100/0/700 kPa
L7	30~/0/150 psi & 100/0/1000 kPa	K6	100/0/1000 kPa
L8	30~/0/200 psi & 100/0/1400 kPa	K7	100/0/1500 kPa
LA	0-15 psi & 0-100 kPa	KA	0-100 kPa
LB	0-30 psi & 0-200 kPa	KB	0-200 kPa
LC	0-60 psi & 0-400 kPa	KC	0-400 kPa
LD	0-100 psi & 0-700 kPa	KO	0-700 kPa
LE	0-160 psi & 0-1000 kPa	KE	0-1000 kPa
LF	0-200 psi & 0-1400 kPa	KF	0-1400 kPa
LG	0-300 psi & 0-2100 kPa	KG	0-2000 kPa
LH	0-400 psi & 0-2800 kPa	KH	0-3000 kPa
LI	0-600 psi & 0-4200 kPa	KP	0-4000 kPa
LJ	0-800 psi & 0-5600 kPa	KI	0-5000 kPa
LK	0-1,000 psi & 0-7000 kPa	KZ	0-7000 kPa
LL	0-1,500 psi & 0-10,500 kPa	KJ	0-10,000 kPa
LM	0-2,000 psi & 0-14,000 kPa	KK	0-15,000 kPa
LN	0-3,000 psi & 0-21,000 kPa	KL	0-20,000 kPa
LO	0-5,000 psi & 0-35,000 kPa	KM	0-40,000 kPa
LP	0-10,000 psi & 0-70,000 kPa	KN	0-100,000 kPa

BAR		CODE	SINGLE SCALE
A1	30~/0 VAC & -1 bar	B2	-1/0 bar
A2	30~/0/15 psi & -1-0-1 bar	B3	-1/1.5 bar
A3	30~/0/30 psi & -1-0-2 bar	B4	-1/3 bar
A4	30~/0/60 psi & -1-0-4 bar	B5	-1/9 bar
A5	30~/0/100 psi & -1-0-7 bar	B6	-1/15 bar
A6	30~/0/150 psi & -1-0-10 bar	B9	-1/24 bar
A7	30~/0/200 psi & -1-0-14 bar	BA	0/1 bar
AC	0-15 psi & 0-1 bar	BB	0/1.6 bar
AD	0-30 psi & 0-2 bar	BC	0/2.5 bar
AE	0-60 psi & 0-4 bar	BD	0/4 bar
AF	0-100 psi & 0-7 bar	BE	0/6 bar
AG	0-160 psi & 0-11 bar	BF	0/10 bar
AH	0-200 psi & 0-14 bar	BG	0/16 bar
AJ	0-300 psi & 0-20 bar	BH	0/25 bar
AK	0-400 psi & 0-27 bar	BI	0/40 bar
AM	0-600 psi & 0-40 bar	BJ	0/60 bar
AO	0-800 psi & 0-56 bar	BK	0/100 bar
AP	0-1,000 psi & 0-70 bar	BL	0/160 bar
AR	0-1,500 psi & 0-100 bar	BM	0/250 bar
AS	0-2,000 psi & 0-140 bar	BN	0/400 bar
AT	0-3,000 psi & 0-200 bar	BO	0/600 bar
AV	0-5,000 psi & 0-350 bar	BP	0/1,000 bar
AY	0-10,000 psi & 0-700 bar	BQ	0/1,600 bar

EQUIVALENTS

1 kPa = 0.14504 psi
 1 bar = 14.5 psi = 100 kPa
 1 kg/cm² = 14.22 psi
 1 in. H₂O = 0.0361 psi
 1 cmHg = 0.1934 psi

EQUIVALENTS
CONVERSION FROM PSI:

1 psi = 6.8947 kPa
 1 psi = .06894 BAR
 1 psi = .07031 kg/cm²

CASE STYLE "Y"

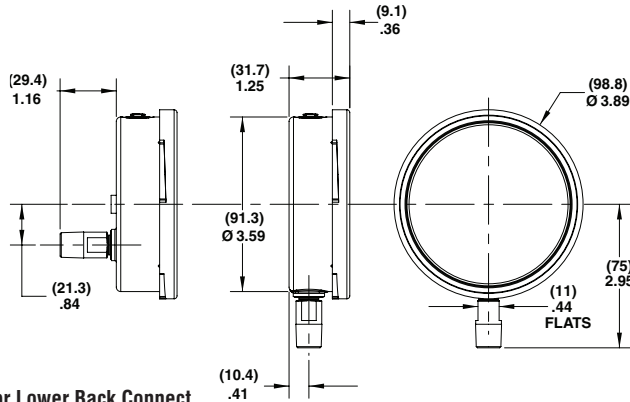

Stem Mount, Lower or Lower Back Connect

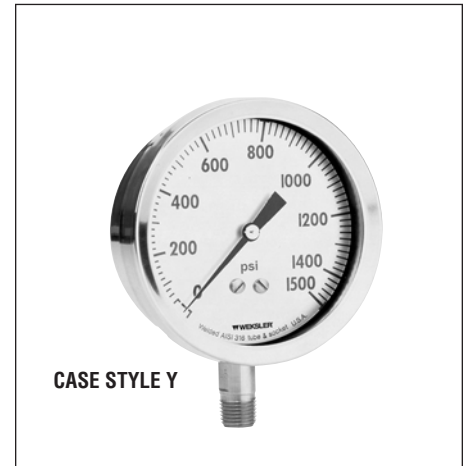

CASE STYLE "X"

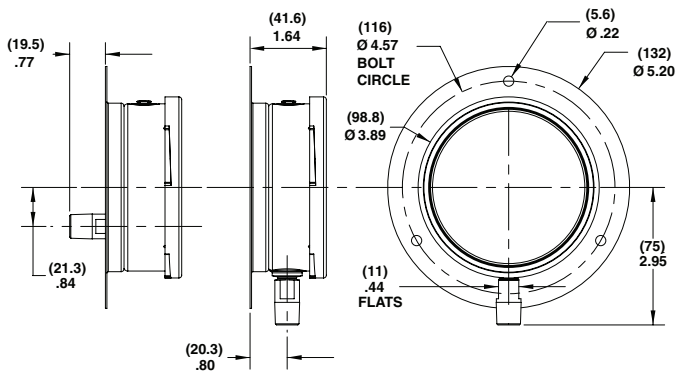

Stem Mount, Lower or Lower Back Connect With Front Flange

CASE STYLE "U"

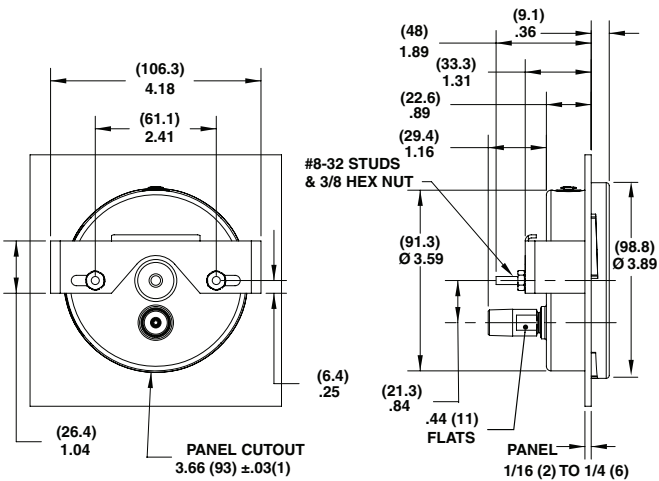

U-Clamp Panel Mount, Lower Back Connect

CASE STYLE "V"

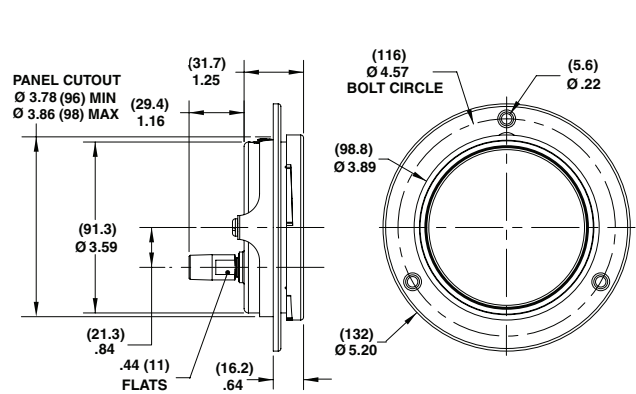

Flush Surface Mount, Lower Back Connect With Back Flange

Note: Dimensions in brackets () are millimeters.

CASE STYLE "Y"

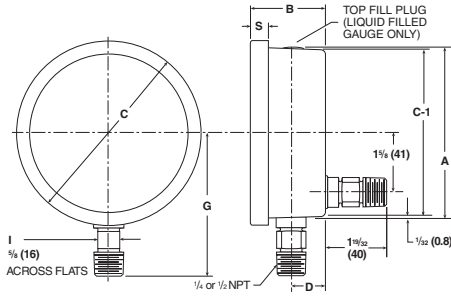

Stem Mount, Lower & Back Connect

Gauge Size	A	B	C	D	F	G	I	S	Weight	
	(100)	(120)	(52)	(129)	(24)	(41)	(100)	(16)	(12)	Dry
4 1/2	4 23/32	2 1/16	5 3/32	1 5/16	1 5/8	3 15/16	5/8	1 5/32	1.75#	2.40#
(100)	(120)	(52)	(129)	(24)	(41)	(100)	(16)	(12)	.79kg	1.1kg

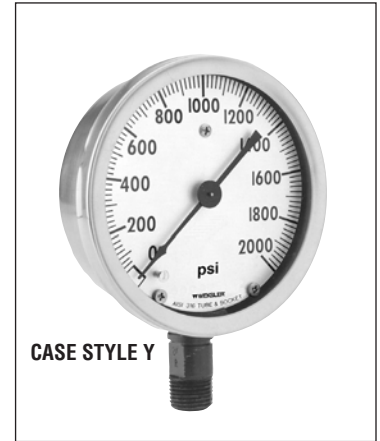

CASE STYLE Y

CASE STYLE "U"

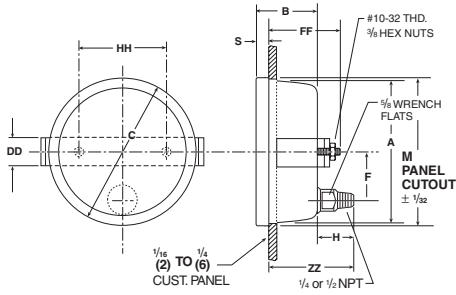

U-Clamp Panel Mount, Back Connect

Gauge Size	A	B	C	DD	F	FF	H	HH	I	M	S	ZZ	Weight	
	(100)	(120)	(52)	(129)	1	1 5/8	2 5/16	1 5/8	3	5/8	4 13/16	1 5/32	3 3/32	Dry
4 1/2	4 23/32	2 1/16	5 3/32	1	1 5/8	2 5/16	1 5/8	3	5/8	4 13/16	1 5/32	3 3/32	1.75#	2.40#
(100)	(120)	(52)	(129)	(25)	(41)	(59)	(41)	(76)	(16)	(122)	(12)	(83)	.79kg	1.1kg

CASE STYLE "X"

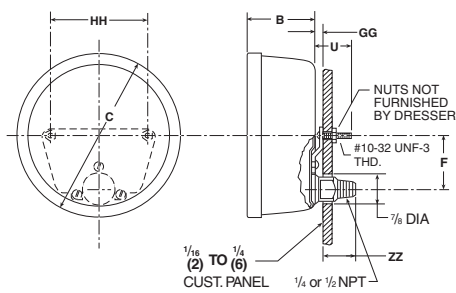

Surface Mount, Back Connect

Gauge Size	A	B	C	F	GG	HH	U	ZZ	Weight	
	(100)	(120)	(52)	(129)	(41)	(5)	(76)	(37)	(37)	Dry
4 1/2	4 23/32	2 1/16	5 3/32	1 5/8	3/16	3	1 7/16	1 7/16	1.75#	2.40#
(100)	(120)	(52)	(129)	(41)	(5)	(76)	(37)	(37)	.79kg	1.1kg

CASE STYLE "V"

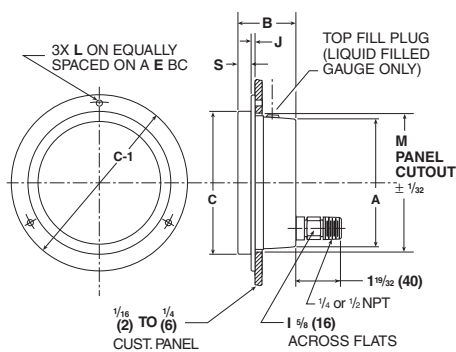

Flush Surface Mount, Back Connect

Gauge Size	A	B	C	C-1	E	I	J	L	M	S	Weight	
	(100)	(120)	(52)	(129)	(160)	5 11/16	5/8	5/32	7/32	4 15/16	1 5/32	Dry
4 1/2	4 23/32	2 1/16	5 3/32	6 3/32	5 11/16	5/8	5/32	7/32	4 15/16	1 5/32	1.75#	2.40#
(100)	(120)	(52)	(129)	(160)	(144)	(16)	(4)	(6)	(125)	(12)	.79kg	1.1kg

CASE STYLE "2"

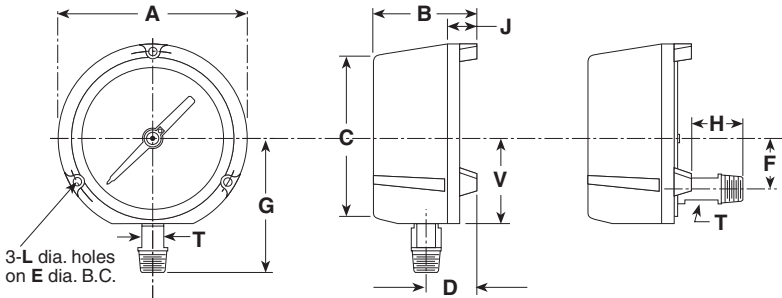

**Surface Mount, Lower & Back Connect
Polypropylene Safety**



Dial Size Inches	A	B	C	D	E	F	G	H	J	L	T	V	Weight (lbs)
4 1/2	5 1/16 (148)	3 3/8 (86)	5 1/16 (129)	1 1/8 (41)	5 3/8 (137)	1 1/8 (41)	3 15/16 (100)	3/4 (20)	1 (25)	(6)	5/8 (16)	2 5/8 (67)	2 1/2

CASE STYLE "4"

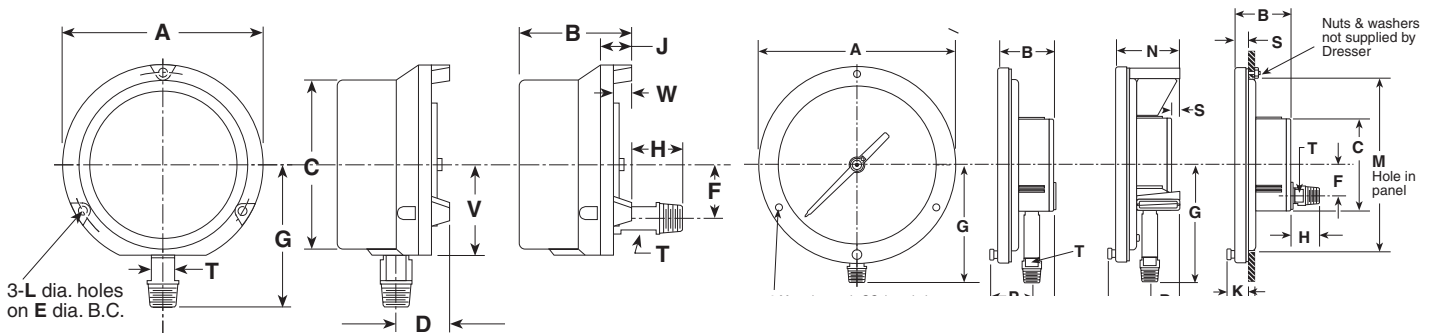

**Surface Mount, Lower & Back Connect
Aluminum Safety**

Dial Size Inches	A	B	C	D	E	F	G	H	J	K
4 1/2	5 1/16 (148)	3 13/32 (86)	4 7/8 (124)	1 1/8 (41)	5 3/8 (137)	1 1/8 (42)	3 15/16 (100)	7/8 (20)	1 1/16 (27)	—
6	7 9/16 (192)	3 1/2 (89)	6 5/8 (162)	1 1/8 (41)	7 (178)	1 1/2 (42)	4 1/2 (114)	(20)	(27)	—
8 1/2	10 1/16 (256)	2 7/8 (73)	4 3/4 (121)	1 1/16 (27)	9 5/8 (244)	1 3/8 (41)	6 (152)	1 3/8 (35)	—	1 1/16 (27)

Dial Size Inches	L	M	N	P	S	T	V	CC	LL	Wgt. (lbs)
4 1/2	.218	—	—	2 1/8 (54)	—	5/8 (16)	2 5/8 (67)	—	—	2 1/2
6	(6)	—	—	(54)	—	(16)	(67)	—	1/8-1/2 (3)(13)	3 3/8
8 1/2	—	9 (228)	3 3/32 (83)	—	1 1/16 (17)	—	—	#10-24	—	4 1/2



CASE STYLE "6"

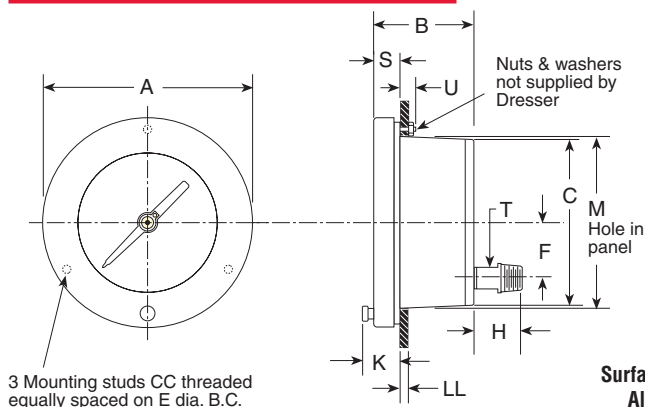

Dial Size Inches	A	B	C	E	F	H	K	M	P	S	T	U	CC	LL	Weight (lbs)
4 1/2	6 3/2 (148)			5 3/2 (137)				4 7/2 (124)					#10-24		2 1/2
6	7 7/16 (192)	2 7/8 (73)	4 3/4 (121)	7 (178)	1 5/8 (41)	1 3/8 (35)	1 1/16 (27)	6 1/2 (165)	2 1/8 (54)	5/8 (16)	5/8 (16)	3/4 (19)	1/4-20	1 1/8-1/2 (3)(13)	3

CASE STYLE "A"

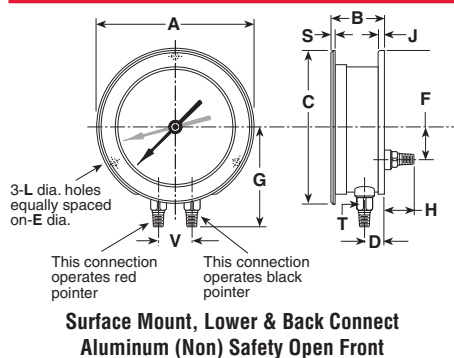

Dial Size Inches	A	B	C	D	E	F	G	H	I	J	L	V	AA	HH	Wgt (lbs)
4 1/2	5 1 3/16 (148)	2 1/4 (57)	5 7/8 (149)	2 7/32 (22)	5 3/8 (137)	1 1/16 (27)	3 25/32 (96)	1 17/32 (39)	1 9/32 (15)	3/8 (10)	7/32 (6)	1 1/2 (38)	—	—	2.4 1.0 kg
6	7 1 1/16 (18)	2 5/8 (67)	6 3/32 (168)	1 5/16 (24)	7 (178)	1 1 1/16 (43)	4 1 5/16 (110)	5 1 5/32 (37)	5/8 (16)	3/16 (5)	5/32 (7)	1 5/8 (42)	—	—	3.6 1.6 kg

CASE STYLE "E"

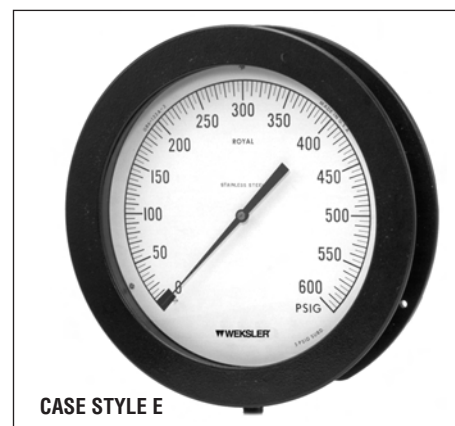
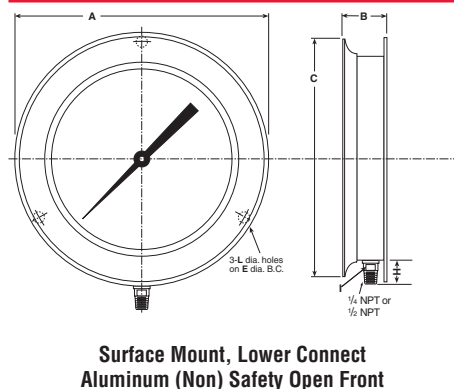

Dial Size Inches	A	B	C	D	E	G	J	K	L	M	S	Wgt (lbs)
12	14 1/2 (368)	2 1 9/16 (75)	14 1/4 (361)	1 1/2 (26)	13 1/2 (343)	7 1/2 (191)	3 1/16 (5)	—	.281 (7)	12 1 1/16 (329)	3 1/16 (5)	8 3.6 kg

GAUGE ACCESSORIES

Accessories/Options/Tools	33-35
Snubbers	36
Gauge Cocks, Needle Valves, Siphons	37

THROTTLING DEVICES

A throttling device should be used when a pressure gauge is subjected to rapid pressure fluctuations, which make the gauge difficult to read because of rapid pointer movement. Such a device reduces pressure impact, slows the speed and range of pointer movement, and prolongs gauge life.

Throttling effect is obtained by installing a restricting orifice between the gauge socket connection and the bourdon tube. Several types are available: throttle screws, pressure snubbers, pulsation dampeners, Gauge Saver® and the Campbell MICRO-BEAN.

Severe service applications are characterized by the presence of significant levels of pressure pulsation and/or vibration. Gauges should be protected from severe pressure pulsation by the inclusion of a dampener such as a throttle plug/screw or porous metal snubber. If the pulsation is extreme, a liquid-filled gauge, with dampener, should be used. A liquid-filled gauge will also last significantly longer than a comparable dry gauge when vibration is present. If the vibration levels are extreme, the only solution may be to remotely mount the gauge away from the source of vibration. In that case capillary tubing may be used to connect the gauge to the pressure source.

THROTTLE SCREWS

The simplest means of providing a restriction in the socket, a throttle screw, should be ordered with the gauge. Threaded or pressed into an instrument socket, the throttle screw orifice selected is based on the viscosity of the pressure fluid, rapidity of pressure fluctuations, and the amount of dampening effect desired.

A smaller orifice should be used for low viscosities, high frequencies, high pres-

sure and reduced pointer amplitude. To accommodate these variables, throttle screws are available in these sizes: 0.0135, 0.020, 0.031, 0.040, and 0.070 inches, in brass and stainless steel. When orifice size or service condition is not specified, a 0.020-inch orifice will be supplied on Royal pressure gauges 0.0135, on 3½" Regal Gauges.

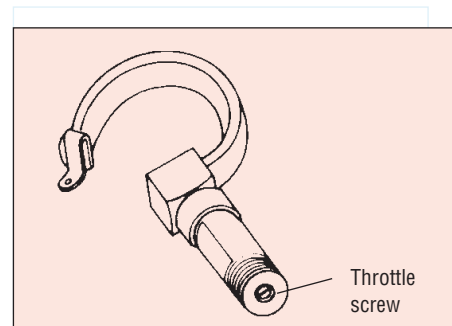

STATIONARY RED SET HAND



Stationary Red Set Hand

to indicate a specific pressure. Ring must be removed to move the hand.

OVERLOAD STOP



Overload Stop

to protect gauge system against extreme overpressure.

SPECIAL DIAL



Special Dial

ranges different from standards, or custom artwork, available on application.

MAXIMUM POINTER

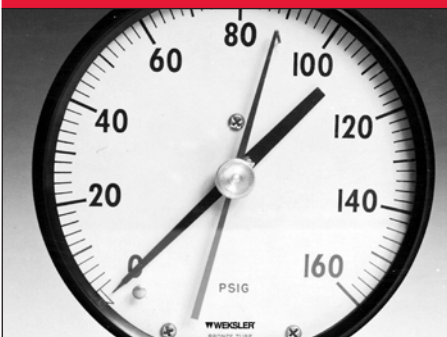

Maximum Pointer

available for gauges 4½" size and larger. Indicates maximum pressure attained. Can be reset by a knob on outside of window.

VACUUM STOP



Vacuum Stop

to protect low range gauges against vacuum.

OPTIONAL WINDOWS

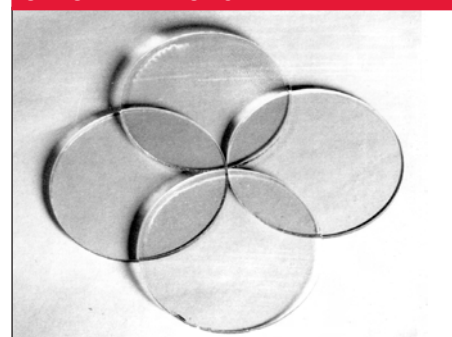

Plastic Disc – optional for glass window
Laminated Safety Glass – optional for glass window
Nonglare Glass – optional for glass window

ELECTRIC WARNING CONTACTS

The electric contact feature is a switching mechanism actuated by the indicating pointer. Switch points are adjustable and can be set throughout the 270° arc. Contacts are used to activate alarms and relays. (Not recommended for continuous switching). The Weksler electric contact is an ideal accessory to turn on a signal light, sound an alarm, or operate a pump or valve. The contacts can easily be set so that a circuit can be closed or opened at a desired pressure or temperature. Settings can be easily made in the field without removing the instrument from service. Contact adjustment is made externally with a removable key to make the instrument virtually tamper proof. Contacts are equipped with adjustable magnets to eliminate chatter caused by vibration. A plug-in connector with five feet of electrical cable is standard.

STANDARD FEATURES

- High impact polycarbonate enclosure for ambient temperature up to 150°F
- Full scale contact adjustment from front of enclosure
- Available on ranges 30 psi and up
- Magnetically assisted, silver alloy contact
- Accuracy $\pm 2\%$ of scale arc (add to instrument accuracy)
- Rated for ¼ amp, 110 volt AC non-inductive load
- Available in: 4½" case styles #2*, #4, #6, "A"
6" case styles #2, #4, #6, "A"

Model	Code	Contact arrangements
2265	XED	High and low contact
	XEE	Double high contact
	XEF	Double low contact
	XEG	"OFF" at low and high, and "ON" in between

* Style case #2 with lower connect comes with DIN Connection. No cable, mating connector available at extra charge.



Indicating accuracy of Royal Gauge, above 300 psi with contact: Pointer not carrying contact – 1.0%. Pointer carrying contact – 1.5%. For ranges below 30 psi, add an additional ½% to indicating accuracies.

TEST GAUGE CARRYING CASE

This rugged blow-molded high-density polyethylene carrying case accommodates the standard 4½", 6 & 8½" Regal analog test gauges. It accepts both lower and back connect gauges. A foam insert protects the gauge when not in use. Type No. 2505.



TOOLS

Hand Jack Set – gauge pointer remover and a pointer set to secure pointer to the shaft. Type No. 3220.

Ring Removal – For the 3½" Regal gauges. Includes 2½" and 3½" wrench and nest. Type No. 1206T.

Small Tools – For the 3½" Regal gauges. Includes pointer puller, span adjust wrench, slotted screw driver for pointer adjustment, pointer staker and pinion backup. Type No. 1205.

Gauge Tool Kit – A complete kit for gauge maintenance. Includes hand jack set, screw driver, five reamers, pin vise holder, wiggler and tweezers all packed in a neat carrying case. Ideal for a gauge maintenance shop. Type No. 1105T.

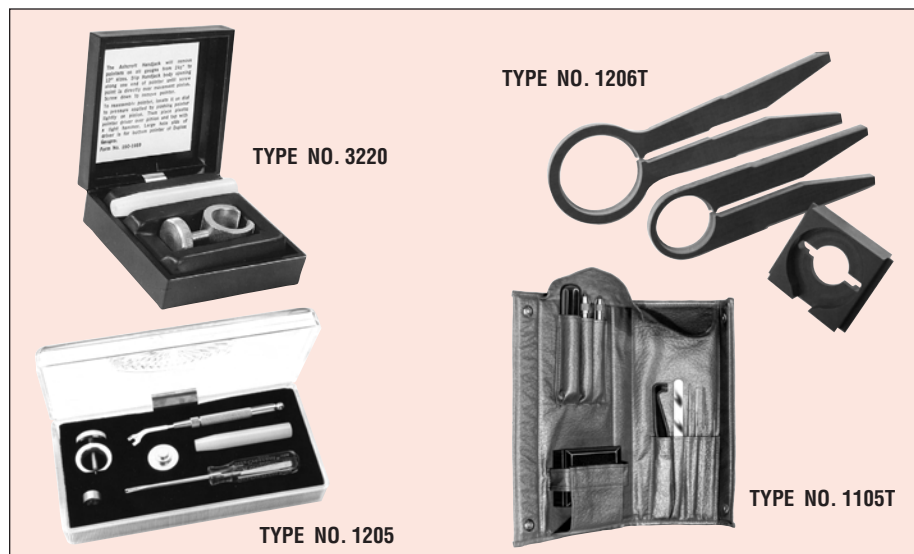

ROYAL AND REGAL GAUGE OPTIONS

CODE	DESCRIPTION
XNN	Paper Tag on Gauge
XNH	SS Tag Wired to Gauge
XMN	SS Tag Wired to Gauge
XOS ⁽¹⁾	Overload Stop
XVS ⁽¹⁾	Underload Stop
XTS	Throttle Screw
XDM	Dial Markings
X6B	Cleaned for Oxygen Service
XGV	Silicone Filled
XSH	Red Set Hand
XSJ	Dual Red Set Hands
XEP*	Max. Indicating Hand
XEQ*	Min. Indicating Hand
XSG	Safety Glass
XPD	Plastic Window
XC1	Certificate of Conformance
XC4	Calibration Certificate

* Not available in 3½" Regal

(1) Standard for 3½"

TYPE 1278M FLUSH MOUNTING RING

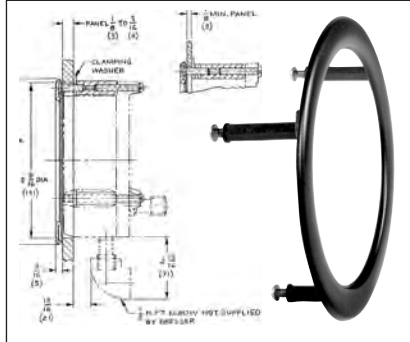

Gauge Size (inches)	Ring O.D. (inches)	A Dia. (inches)	"B"-Three Screws
			Size
4½	6.000	5.625	#10-24 x 1½"
67.765	7.25	¼-20 x 1½"	

Used to flush-mount 4½" and 6" Royal and bellows type gauges. Standard finish is black; polished stainless steel finish is available at an extra charge, 4½" and 6".

FLUSH MOUNTING RING

CODE	DESCRIPTION	TYPE	MOUNTING MATERIAL
56	Flush Mounting	1278M	Black
57	Rings*	1278MC	Polished SS

*For 4½" and 6" Royal / Regal gauges manufactured after 10/1/04

TYPE A-1285

Ring Wrench – 4½"

(For installing front threaded rings in 4½" #2, #4 safety cases)

TYPE A-1286

Ring Wrench – 6"

(For installing front threaded rings in 6" #4 aluminum safety cases)

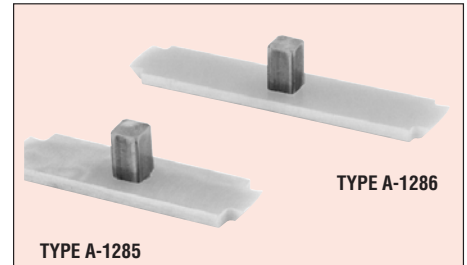

TYPE A-1285

TYPE A-1286

FILTER TYPE

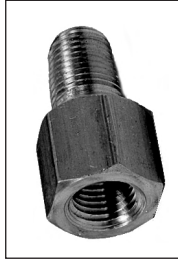
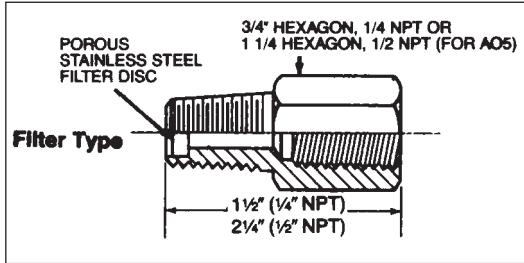

Filter Type: Snubbing element consists of a $\frac{3}{8}$ " diameter x $\frac{1}{8}$ " thick Micro Metallic stainless steel filter. When placed in the line just before the pressure gauge, the gauge pointer moves across the scale at a rate which is proportional to the pressure differential across the snubber element.

TYPE NUMBER	GAS OR LIQUID IN PIPE LINE	PRESSURE RANGE	CONNECTION	MATERIAL
BW 41 BW 42 BW 43	Air Water-Light Oil Heavy Oil	1,500 psi	1/4 NPT	Brass
SW 41 SW 42 SW 43	Air Water-Light Oil Heavy Oil	5,000 psi	1/4 NPT	SS
A05D A05E A05G	Heavy Oil Water Light Oil Air	20,000 psi	1/2 NPT	SS

PISTON TYPE

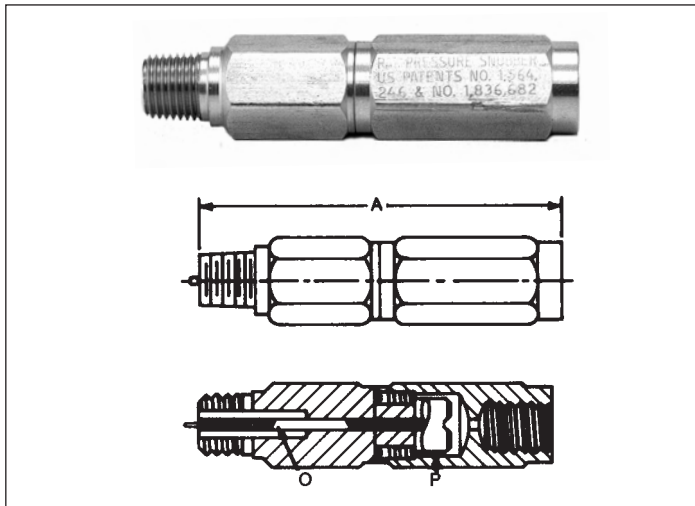

Piston Type: Shocks and pulsations are absorbed in the doughnut-shaped orifice (O) formed by the piston (P) in the tube. As the piston moves up and down with the pulsation, it automatically clears away any sediment or pipe scale that would clog a simple orifice or needle valve.

Each snubber is furnished with three pistons. The snubbing may be changed to suit individual installations by changing pistons. By using the proper piston, any of the listed snubbers can be made to operate satisfactorily from vacuum to its maximum rated pressure on any fluid compatible with the body material. These snubbers may be installed vertically, horizontally, inverted, or at any angle.

TYPE NUMBER	GAS OR LIQUID IN PIPE LINE	PRESSURE RANGE LBS.	PIPE SIZE AND LENGTH	MATERIAL
RS1	Air, water, steam, etc.	0-3000	1/4 NPT	Brass
RS7	Thin corrosive liquid, gases	0-5,000	A = 3 1/2"	SS
RS8	Thick corrosive liquids		1/2 NPT	Brass
RS6	Oil, water, etc.	0-10,000	A = 3 5/8"	SS
RS9	Thin or thick corrosive			

ADJUSTABLE SNUBBER



MODEL	MAX. WORKING PRESS.	BODY MATERIAL	LENGTH O.A.	THREAD LENGTH	THREAD SIZE
MSB4	3,000	Brass	1.60	.50	1/4 NPT
MSB2	3,000	Brass	2.28	.80	1/2 NPT
MSS4	5,000	316SS	1.60	.50	1/4 NPT
MSS2	10,000	316SS	2.28	.80	1/2 NPT

NOTE: The adjusting screw, ball and ball retainer are Stainless Steel, Buna N Seals are standard. Teflon, Viton and Butyl Seals are available.

Adjustable Snubber

The Universal Adjustable Snubber has a ball check cut-off to block line surges, shock waves and fluid hammer; and an adjustable fine thread choke valve to tune out line pulsations. The combination of the ball cut-off and a tunable choke valve makes it an all-purpose, universal Snubber that is used on low displacement instruments such as bourdon tube gauges which require heavy dampening; and with high displacement instruments such as diaphragm, piston and bellows operated gauges, recorders and controllers, which require moderate to heavy dampening.

The adjustable choke valve is also used as a positive shut-off valve, to isolate the gauge or instrument, for servicing or replacement.

The operation of the Adjustable Snubber cut-off ball and the choke valve is shown in the chart. The cut-off ball blocks and clamps off shock and hammer transients in the line, which are above the normal pressure level in the system. The choke valve throttles and dampens out pulsations and cyclic pressure waves, and may be adjusted to dampen out to any level desired to prevent pointer oscillation on gauges, chart painting on recorders, instability in controllers or, damage to instruments, generally.

BRASS GAUGE COCKS

TYPE NO.	TYPE	CONNECTIONS	MAXIMUM PRESSURE
A10	Tee Handle - Brass	¼" Female	125 psi
A10C	Tee Handle - Chrome Plated	¼" Female	125 psi
A10E	Heavy Duty Tee Handle	¼" Female	200 psi
A11	Lever Handle - Brass	¼" Male and Female	200 psi
A12	Lever Handle - Brass	¼" Female	200 psi
A20	Tee Handle - Brass	½" Female	200 psi

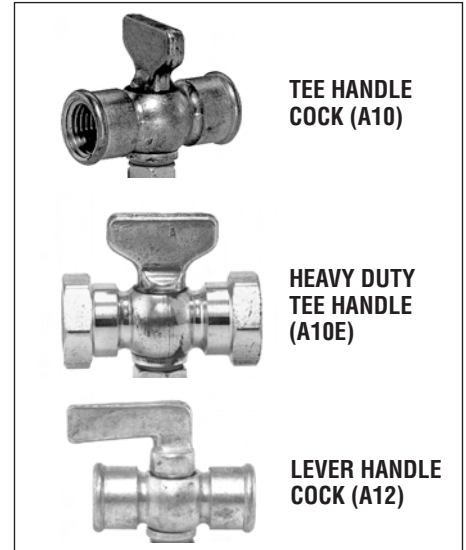
BAR STOCK NEEDLE VALVES

These valves are used primarily to closely regulate fine flow. However, they may be used as a throttling device on lines where rapid and excessively pulsating pressures would tend to effect the gauge performance or mechanism.

TYPE NO.	SIZE	MATERIAL	PRESSURE & TEMP. RATING
BBV4	¼ NPT	Brass: For oil, water, gas, etc.	600 psi @ 300°F
SSV4	¼ NPT	303 Stainless Steel: For oil, water, gas, etc.	5000 psi @ 500°F
AV34	¼ NPT	Bronze: For oil, water, gas, etc.	500 psi @ 150°F
AV32	½ NPT		
AV44	¼ NPT	Carbon Steel: Parkerized and Parcolaced, for resistance to corrosion.	475 psi @ 1,000°F 550 psi @ 900°F 600 pssi @ 850°F 10,000 psi @ 150°F
AV42	½ NPT		
AV74	¼ NPT	316 Stainless Steel provides greatest overall resistance to corrosion; very good for sub-zero service.	4,000 psi @ 150°F
AV72	½ NPT		

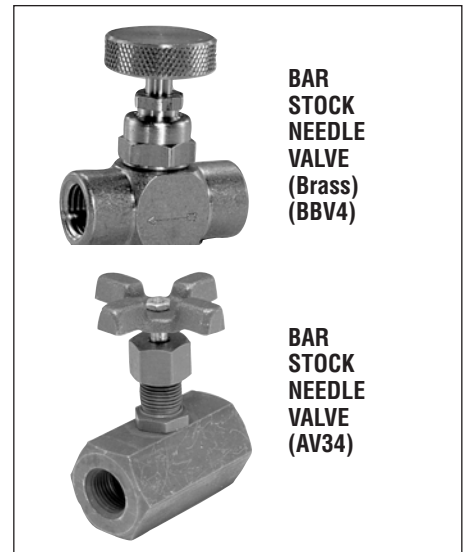
SIPHONS

When a gauge is to be used for steam pressures, a siphon filled with water is recommended between the line and gauge to prevent high temperature steam from entering the gauge bourdon tube.

TYPE NO.	SIZE	SIPHON MATERIAL	CAPACITY
A03I	¼ NPT	Iron (Schedule 40)	500 psi and 400°F
A03B		Brass	250 psi and 400°F
CPS4		Seamless Steel, extra heavy (Schedule 80)	1,000 psi and 850°F
CPSS4		Seamless Stainless Steel XH (Schedule 80)	2,000 psi and 1000°F
CPS2	½ NPT	Steel (Schedule 80)	1,000 psi and 850°F
CPSS2		Seamless Stainless Steel XH (Schedule 80)	2,000 psi and 1000°F



GAUGE TOOLS — Hand Jack: for removing pointer. Specify Type A01. **Hand Set:** for installing pointer. Specify Type A02

ECONOMY UTILITY GAUGES

Dry Gauges	41
Liquid Filled Gauges.....	42-44
Contractor Gauges	45



Dry Gauges, Steel Case, Bronze Tube, Brass Socket, ±3-2-3% Accuracy

STANDARD FEATURES

- Available in 1½", 2", 2½" and 3½" sizes
- Black finish steel case and ring with plastic window
- Panel gauge case is black finish steel with studs and chrome-plated ring.
- Panel mount gauges available in 1½", 2" and 2½" sizes
- ½ NPT lower and back connection available 1½" size; ¼ NPT lower and back connection available in 2" and 2½" sizes; ¼ NPT lower connection available in 3½" size
- Dual scale dials with bar/kPa in blue (inner scale); psi in black (outer scale); on white background

CATALOG NUMBERS

Dial Size	1½"		2"		2½"		3½"
	Back	Bottom	Back	Bottom	Back	Bottom	
Connection Location							
Connection NPT	½"	½"	¼"	¼"	¼"	¼"	¼"
Range (psi/bar/kPa)							
30"0/vac. and -1/0 bar (-100/0 kPa)	UA15H8C	UA15H8L	UA20H4C	UA20H4L	UA25H4C	UA25H4L	UA35H4L
30"0/30 psi and -1/0/2 bar (-100/0/200 kPa)	-	-	UA20J4C	UA20J4L	-	UA25J4L	UA35J4L
30"0/60 psi and -1/0/4 bar (-100/0/400 kPa)	-	-	-	UA20K4L	-	UA25K4L	UA35K4L
30"0/150 psi and -1/0/10 bar (-100/0/1000 kPa)	-	-	-	-	UA25L4C	UA25L4L	UA35L4L
30"0/300 psi and -1/0/10 bar (-100/0/2000 kPa)	-	-	-	-	-	UA25M4L	UA35M4L
0-15 psi and 1 bar (100 kPa)	UA15N8C	UA15N8L	UA20N4C	UA20N4L	UA25N4C	UA25N4L	UA35N4L
0-30 psi and 2 bar (200 kPa)	UA15A8C	UA15A8L	UA20A4C	UA20A4L	UA25A4C	UA25A4L	UA35A4L
0-60 psi and 4 bar (400 kPa)	UA15B8C	UA15B8L	UA20B4C	UA20B4L	UA25B4C	UA25B4L	UA35B4L
0-100 psi and 7 bar (700 kPa)	UA15C8C	UA15C8L	UA20C4C	UA20C4L	UA25C4C	UA25C4L	UA35C4L
0-160 psi and 11 bar (1100 kPa)	UA15D8C	UA15D8L	UA20D4C	UA20D4L	UA25D4C	UA25D4L	UA35D4L
0-200 psi and 14 bar (1400 kPa)	UA15E8C	UA15E8L	UA20E4C	UA20E4L	UA25E4C	UA25E4L	UA35E4L
0-300 psi and 21 bar (2100 kPa)	-	-	UA20F4C	UA20F4L	UA25F4C	UA25F4L	UA35F4L
0-600 psi and 42 bar (4200 kPa)	-	-	-	UA20G4L	-	UA25G4L	UA35G4L

To order: specify the "catalog number" from table above. For panel mount gauges (back connection only) add "-UC" to the 7 digit catalog number. (The following catalog numbers are not available as panel mount: UA20K4C, UA20E4C, UA25K4C, UA25E4C).



GAUGE DIMENSIONS UA15, UA20, UA25, UA35

Lower Connection Gauge Size/Type		A	B	C	D		E	F
					½"	¼"		
UA15	Inch	1.66	0.99	1.45	0.33	-	0.32	1.61
	mm	42	25	37	8	-	5	41
UA20	Inch	2.08	1.13	1.80	-	0.37	0.39	2.01
	mm	53	28	46	-	9	10	51
UA25	Inch	2.48	1.13	1.95	-	0.42	0.39	2.43
	mm	63	29	50	-	11	10	62
UA35	Inch	3.47	1.16	2.68	-	0.46	0.43	3.42
	mm	88	29	68	-	12	11	87

Back Connection Gauge Size/Type		A	B	E	F	G	H
UA15	Inch	1.66	.99	0.31	1.61	1.56	½"
	mm	42	25	8	41	40	
UA20	Inch	2.08	1.13	0.39	2.01	1.85	¼"
	mm	53	29	10	51	47	
UA25	Inch	2.48	1.13	0.39	2.44	1.87	¼"
	mm	63	29	10	62	47	

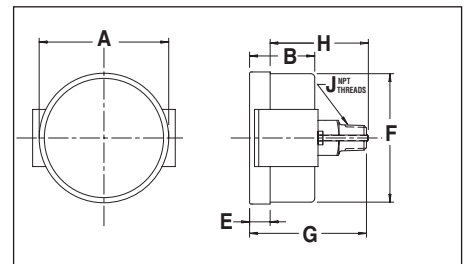
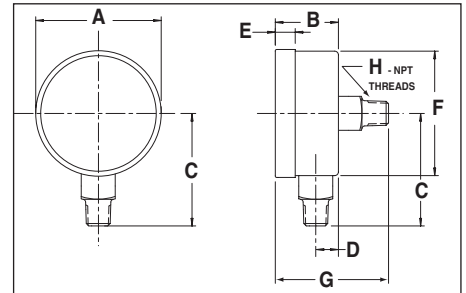

GAUGE DIMENSIONS UA15-UC, UA20-UC, UA25-UC

Back Connection Gauge Size/Type		A	B	E	F	G	H	J
UA15	Inch	1.78	1.00	0.20	1.62	1.60	1.24	½"
	mm	45	25	5	41	41	31	
UA20	Inch	2.20	1.10	0.18	2.01	1.81	1.59	¼"
	mm	56	28	4	51	46	40	
UA25	Inch	2.62	1.15	0.23	2.47	1.83	1.67	¼"
	mm	66	29	6	63	46	42	

PANEL CUT-OUT

Panel Cut-Out	Hole Diameter		Max. Panel Thickness
	Minimum Inches (mm)	Maximum Inches (mm)	
1½" Gauge	1.615	1.665	½"
2" Gauge	2.035	2.095	7/16"
2½" Gauge	2.462	2.538	7/16"

STANDARD FEATURES

- Available in 40mm, 50mm, 63mm and 100mm sizes
- Stainless steel case and ring with plastic window
- 1/8" NPT back connection available in 40mm size; 1/4" NPT lower and back connection available in 50mm and 63mm sizes; 1/4" NPT lower connection available in 100mm size
- Dual scale dials with bar/kPa in blue (inner scale); psi in black (outer scale); on white background
- Panel mount kits available

CATALOG NUMBERS

Dial Size	40mm	50mm		63mm		100mm
Connection Location	Back	Back	Bottom	Back	Bottom	Bottom
Connection NPT	1/8"	1/4"	1/4"	1/4"	1/4"	1/4"
Range (psi/bar/kPa)						
3070/ vac. and -1/0 bar(-100/0 kPa)	BY10YVC8CW	BY11YVC4CW	—	BY12YVC4CW	BY12YVC4LW	BY14YVC4LW
3070/30 psi and -1/0/2 bar (-100/0/200 kPa)	—	—	—	BY12YCB4CW	BY12YCB4LW	—
3070/60 psi and -1/0/4 bar (-100/0/400 kPa)	—	BY11YCC4CW	—	—	BY12YCC4LW	BY14YCC4LW
3070/150 psi and -1/0/10 bar (-100/0/1000 kPa)	—	—	—	BY12YCE4CW	BY12YCE4LW	—
0-15 psi and 0/1 bar (100 kPa)	—	—	—	BY12YPC4CW	—	—
0-30 psi and 0/2 bar (200 kPa)	BY10YPD8CW	—	BY11YPD4LW	BY12YPD4CW	BY12YPD4LW	BY14YPD4LW
0-60 psi and 0/4 bar (400 kPa)	BY10YPE8CW	BY11YPE4CW	BY11YPE4LW	BY12YPE4CW	BY12YPE4LW	BY14YPE4LW
0-100 psi and 0/7 bar (700 kPa)	BY10YPF8CW	BY11YPF4CW	BY11YPF4LW	BY12YPF4CW	BY12YPF4LW	BY14YPF4LW
0-160 psi and 0/11 bar (1100 kPa)	BY10YPG8CW	BY11YPG4CW	BY11YPG4LW	BY12YPG4CW	BY12YPG4LW	BY14YPG4LW
0-200 psi and 0/14 bar (1400 kPa)	—	—	—	BY12YPH4CW	BY12YPH4LW	—
0-300 psi and 0/21 bar (2100 kPa)	BY10YPJ8CW	—	BY11YPJ4LW	BY12YPJ4CW	BY12YPJ4LW	BY14YPJ4LW
0-600 psi and 0/42 bar (4200 kPa)	—	—	—	BY12YPM4CW	BY12YPM4LW	—
0-1000 psi and 0/70 bar (7000 kPa)	BY10YPP8CW	—	BY11YPP4LW	BY12YPP4CW	BY12YPP4LW	BY14YPP4LW
0-2000 psi and 0/140 bar (14,000 kPa)	—	—	—	BY12YPS4CW	BY12YPS4LW	—
0-3000 psi and 0/210 bar (21,000 kPa)	BY10YPT8CW	—	BY11YPT4LW	BY12YPT4CW	BY12YPT4LW	BY14YPT4LW
0-5000 psi and 0/350 bar (35,000 kPa)	BY10YPV8CW	—	BY11YPV4LW	BY12YPV4CW	BY12YPV4LW	—
0/10,000 psi and 0/700 bar (70,000 kPa)	—	—	BY11YPY4LW	BY12YPY4CW	BY12YPY4LW	—

To order: specify 10-digit "catalog number" from above table. For panel mount gauges (back connection only) add "-UC" to 10-digit catalog number.

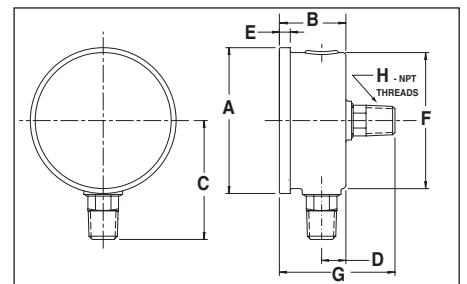

GAUGE DIMENSIONS BY10Y, BY11Y, BY12Y, BY14Y

Lower Connection Gauge Size/Type		A	B	C	D-1/4	E	F	
50 mm	BY11Y	Inch	2.21	1.11	1.86	0.37	0.19	2.01
		mm	56	28	47	9	5	51
63 mm	BY12Y	Inch	2.62	1.13	2.08	0.39	0.22	2.45
		mm	66	29	53	10	5	75
100 mm	BY14Y	Inch	4.29	1.42	3.14	0.46	0.29	3.88
		mm	109	36	80	12	7	98
Back Connection Gauge Size/Type		A	B	F	G	H		
40 mm	BY10Y	Inch	1.78	1.00	1.61	1.62	1/8"	
		mm	45	25	41	41		
50 mm	BY11Y	Inch	2.21	1.11	2.02	2.05	1/4"	
		mm	56	28	51	52		
63 mm	BY12Y	Inch	2.62	1.13	2.45	2.05	1/4"	
		mm	66	29	62	52		

PANEL MOUNT ASSEMBLY FOR 40mm, 50mm, 63mm GAUGES

Part No.		A	B	C	D	E	F	G	H	J	K
40mm Clamp	Inch	2.36	1.02	189	0.45	0.44	0.94	0.94	0.20	0.10	M5X0.8
	mm	60	26	48	11.6	11.3	24	24	5	2.50	M5X0.8
50mm Clamp	Inch	2.83	1.26	236	0.57	0.56	0.47	1.18	0.24	0.10	M5X0.8
	mm	72	32	60	14.6	14.2	30	72	6	2.50	M5X0.8
63mm Clamp	Inch	3.27	1.26	280	0.57	0.56	0.47	1.40	0.24	0.10	M5X0.8
	mm	83	32	71	14.6	14.2	12	35.5	6	2.50	M5X0.8

PANEL MOUNT PART NUMBER

ITEM - NO.
U-clamp 40
U-clamp 50
U-clamp 63

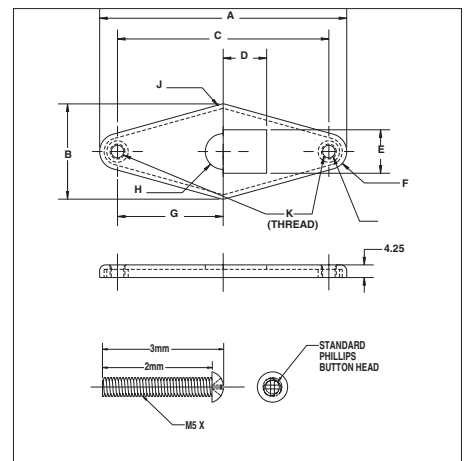

STANDARD FEATURES

- Available in 40mm, 50mm, 63mm and 100mm sizes
- Stainless steel case and ring with plastic window
- 1/8 NPT back connection available in 40mm size; 1/4 NPT lower and back connection available in 50mm and 63mm sizes; 1/4 NPT lower connection available in 100mm size
- Dual scale dials with bar/kPa in blue (inner scale); psi in black (outer scale); on white background
- Panel mount kits available

CATALOG NUMBERS

Dial Size	40mm		50mm		63mm		100mm
Connection Location	Back	Back	Bottom	Back	Bottom	Bottom	Bottom
Connection NPT	1/8	1/4	1/4	1/4	1/4	1/4	1/4
Range (psi/bar/kPa)							
30"70/ vac. and -1/0 bar(-100/0 kPa)	BY40YVC8CW	—	—	BY42YVC4CW	BY42YVC4LW	BY45YVC4LW	—
30"70/30 psi and -1/0/2 bar (-100/0/200 kPa)	—	—	—	BY42YCB4CW	BY42YCB4LW	—	—
30"70/60 psi and -1/0/4 bar (-100/0/400 kPa)	—	—	—	BY42YCC4CW	BY42YCC4LW	BY45YCC4LW	—
30"70/150 psi and -1/0/10 bar (-100/0/1000 kPa)	—	—	—	BY42YCE4CW	BY42YCE4LW	—	—
0-15 psi and 0/1 bar (100 kPa)	—	—	—	BY42YPC4CW	BY42YPC4LW	—	—
0-30 psi and 0/2 bar (200 kPa)	BY40YPD8CW	BY41YPD4CW	—	BY42YPD4CW	BY42YPD4LW	BY45YPD4LW	—
0-60 psi and 0/4 bar (400 kPa)	BY40YPE8CW	BY41YPE4CW	—	BY42YPE4CW	BY42YPE4LW	BY45YPE4LW	—
0-100 psi and 0/7 bar (700 kPa)	—	BY41YPF4CW	BY41YPF4LW	BY42YPF4CW	BY42YPF4LW	BY45YPF4LW	—
0-160 psi and 0/11 bar (1100 kPa)	BY40YPG8CW	BY41YPG4CW	BY41YPG4LW	BY42YPG4CW	BY42YPG4LW	BY45YPG4LW	—
0-200 psi and 0/14 bar (1400 kPa)	—	—	—	BY42YPH4CW	BY42YPH4LW	—	—
0-300 psi and 0/21 bar (2100 kPa)	BY40YPJ8CW	BY41YPJ4CW	—	BY42YPJ4CW	BY42YPJ4LW	BY45YPJ4LW	—
0-600 psi and 0/42 bar (4200 kPa)	—	—	—	BY42YPM4CW	BY42YPM4LW	—	—
0-1000 psi and 0/70 bar (7000 kPa)	—	—	BY41YPP4LW	BY42YPP4CW	BY42YPP4LW	BY45YPP4LW	—
0-2000 psi and 0/140 bar (14,000 kPa)	—	—	—	BY42YPS4CW	BY42YPS4LW	—	—
0-3000 psi and 0/210 bar (21,000 kPa)	—	—	—	BY42YPT4CW	BY42YPT4LW	BY45YPT4LW	—
0-5000 psi and 0/350 bar (35,000 kPa)	—	—	—	BY42YPV4CW	BY42YPV4LW	BY45YPV4LW	—
0/10,000 psi and 0/700 bar (70,000 kPa)	—	—	—	BY42YPY4CW	BY42YPY4LW	BY45YPY4LW	—

To order: specify 10-digit "catalog number" from above table. For panel mount gauges (back connection only) add "-UC" to 10-digit catalog number.

GAUGE DIMENSIONS BY40Y, BY41Y, BY42Y, BY45Y

Lower Connection Gauge Size/Type		A	B	C	D-1/4	E	F	
50 mm	BY41Y	Inch	2.21	1.11	1.86	0.37	0.19	
		mm	56	28	47	9	5	
63 mm	BY42Y	Inch	2.62	1.13	2.08	0.39	0.22	
		mm	66	29	53	10	5	
100 mm	BY45Y	Inch	4.29	1.42	3.14	0.46	0.29	
		mm	109	36	80	12	7	
Back Connection Gauge Size/Type		A	B	F	G	H		
40 mm	BY40Y	Inch	1.78	1.00	1.61	1.62	1/8	
		mm	45	25	41	41		
50 mm	BY41Y	Inch	2.21	1.11	2.02	2.05	1/4	
		mm	56	28	51	52		
63 mm	BY42Y	Inch	2.62	1.13	2.45	2.05	1/4	
		mm	66	29	62	52		

PANEL MOUNT ASSEMBLY DIMENSIONS FOR 40mm, 50mm, 63mm GAUGES

Part No.	A	B	C	D	E	F	G	H	J	K
40mm Clamp	Inch	2.36	1.02	189	0.45	0.44	0.94	0.94	0.20	0.10
	mm	60	26	48	11.6	11.3	24	24	5	2.50
50mm Clamp	Inch	2.83	1.26	236	0.57	0.56	0.47	1.18	0.24	0.10
	mm	72	32	60	14.6	14.2	30	72	6	2.50
63mm Clamp	Inch	3.27	1.26	280	0.57	0.56	0.47	1.40	0.24	0.10
	mm	83	32	71	14.6	14.2	12	35.5	6	2.50

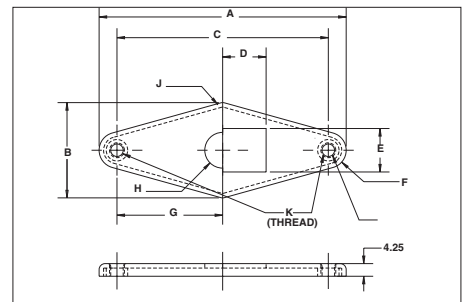
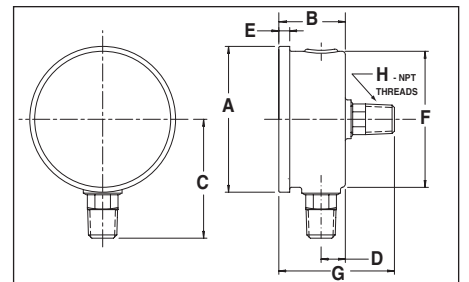

PANEL MOUNT PART NUMBER

ITEM - NO.
U-clamp 40
U-clamp 50
U-clamp 63

STANDARD FEATURES

- Available in 63mm size
- Cast brass case and brass plated plastic ring with plastic window
- ¼ NPT lower and back connection available
- Dual scale dials with kPa in blue (outer scale); psi in black (inner scale); on white background



BY12JPV4LW

BY12JPE4CW

CATALOG NUMBERS

Dial Size	63mm	
	Back	Bottom
Connection Location	Back	Bottom
Connection NPT	¼	¼
Range (psi & kPa)		
30"/0/ vac. and -100/0 kPa	BY12JVC4CW	
30"/0/30 psi and -100/0/200 kPa		
30"/0/60 psi and -100/0/400 kPa	BY12JCC4CW	BY12JCC4LW
30"/0/150 psi and -100/0/1000 kPa		
0-15 psi and 100 kPa		
0-30 psi and 200 kPa	BY12JPD4CW	BY12JPD4LW
0-60 psi and 400 kPa	BY12JPE4CW	BY12JPE4LW
0-100 psi and 700 kPa		BY12JPF4LW
0-160 psi and 1100 kPa		BY12JPG4LW
0-200 psi and 1400 kPa		
0-300 psi and 2100 kPa	BY12JPJ4CW	BY12JPJ4LW
0-600 psi and 4200 kPa		
0-1000 psi and 7000 kPa		BY12JPP4LW
0-2000 psi and 14,000 kPa		
0-3000 psi and 21,000 kPa		BY12JPT4LW
0-5000 psi and 35,000 kPa	BY12JPV4CW	BY12JPV4LW
0/10,000 psi and 70,000 kPa	BY12JPY4CW	BY12JPY4LW

To order: specify 10-digit "catalog number" from above table.

GAUGE DIMENSIONS BY12J

Lower Connection Gauge Size/Type		A	B	C	D-¼	E	F	
63 mm	BY12J	Inch	2.60	1.50	2.20	0.41	1.21	2.44
		mm	66	38	56	10	31	62
Back Connection Gauge Size/Type		A	B	F	G			
63 mm	BY12J	Inch	2.60	1.50	2.44	2.46		
		mm	66	38	62	62		

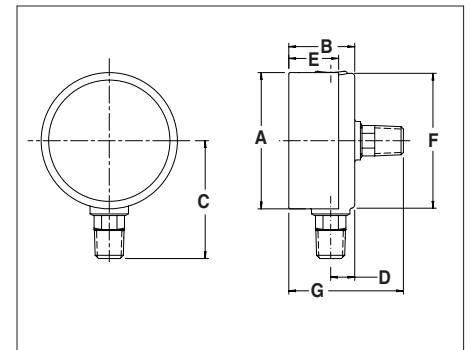

STANDARD FEATURES

- 4 1/2" diameter
- Corrosion Resistant Stainless Steel Case and Ring, Plastic Lens.
- Zero adjusting screw.
- Soft soldered phosphor bronze tube with brass socket. Suitable for steam, water, air, oil, gas or any medium not corrosive to copper alloys.
- Bronze/brass movement.
- Easy to read dial; white background with bold black numerals and graduations, 270° arc.
- 1/4 NPT bottom connection only.

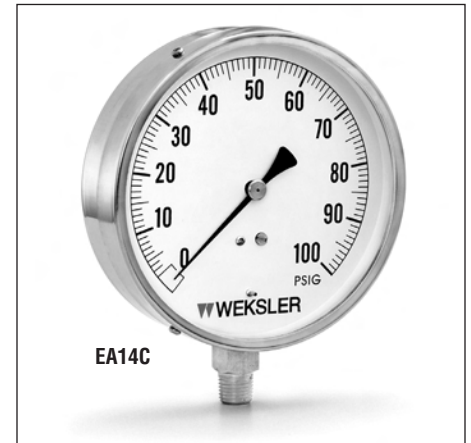
PRESSURE RANGES

CATALOG NO	DIAL RANGES	FIGURE INTERVALS	SMALLEST GRADUATION
EA14A	0- 30 psi	5 psi	1/2 psi
EA14B	0- 60 psi	10 psi	1 psi
EA14C	0-100 psi	10 psi	1 psi
EA14D	0-160 psi	20 psi	2 psi
EA14E	0-200 psi	20 psi	2 psi
EA14F	0-300 psi	50 psi	5 psi
EA14G	0-500 psi	50 psi	5 psi

VACUUM RANGES

EA14H	30"-0 Hg. Vac	5 in.	1/2 in.
-------	---------------	-------	---------

COMPOUND RANGES

EA14J	30"-0- 30 psi	10" & 5 psi	1" & 1 psi
EA14K	30"-0-100 psi	15" & 10 psi	5" & 1 psi
EA14L	30"-0-150 psi	30" & 25 psi	5" & 5 psi

TO ORDER: SPECIFY 5 DIGIT "CATALOG NUMBER" FROM ABOVE TABLE.

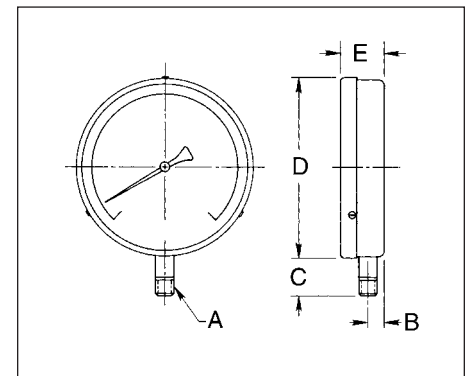
DIMENSIONS

GAUGE DIMENSIONS – EA14C

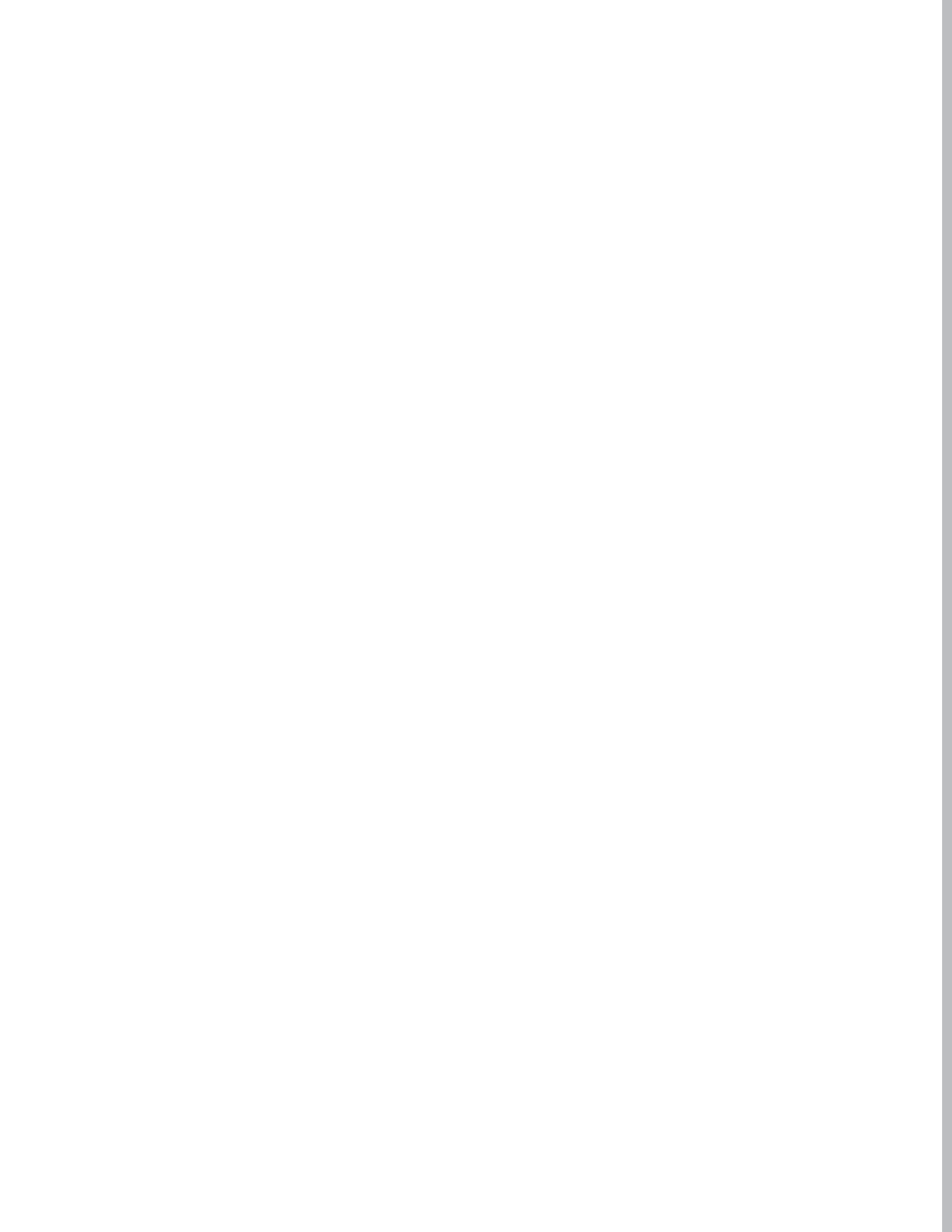
A	B	C	D	E
1/4 NPT	7/16	1 1/16	4 15/16	1 3/16
	(11)	(27)	(126)	(30)



LINE ASSEMBLIES

1115A/1115P Line Assemblies49

Line Assemblies Type 1115A/1115P All Welded

Weksler® line assemblies are offered in a wide variety of configurations to suit all of your applications. Our standard assembly is in an all welded design of 300 series stainless components. The capillary is 304 stainless steel with an O.D. of 125 x .062 I.D. A spiral wound armor shields the assembly.

$\frac{1}{4}$ " or $\frac{1}{2}$ " male or female connections are available. Other connections available upon request. PVC jacketed line assemblies are also available.

- All welded construction
- Type 1115A is our standard stainless steel armored capillary
- Type 1115P stainless steel armored capillary, with the addition of PVC sheathing for maximum corrosion resistance
- The assemblies have standard line lengths of five feet in increments of five feet
- Line lengths in one foot increments are available with one foot being the minimum allowed, 150 feet being the maximum

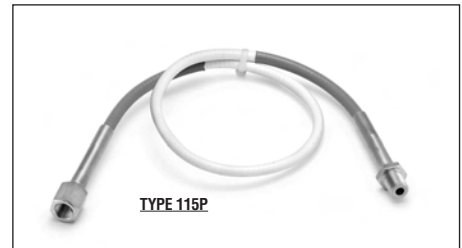
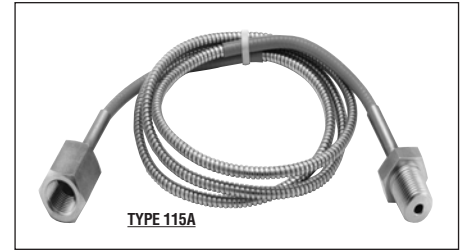

SELECTION TABLES

**Table A –
Process Connection**

Process Connection	Size	Code
Threaded – male NPT	$\frac{1}{4}$	02
Threaded – male NPT	$\frac{1}{2}$	04
Threaded – female NPT	$\frac{1}{4}$	25
Threaded – female NPT	$\frac{1}{2}$	50

**Table B –
Type**

Description	Code
Stainless steel armored capillary	1115A
Stainless steel armored capillary w/PVC sheathing	1115P

**Table C –
Instrument Connection**

Instrument Connection	Size	Code
Threaded – male NPT	$\frac{1}{4}$	02
Threaded – male NPT	$\frac{1}{2}$	04
Threaded – female NPT	$\frac{1}{4}$	25
Threaded – female NPT	$\frac{1}{2}$	50

**Table D –
Example Lengths**

Example Lengths	Feet	Code
Increments of	1	001
Increments of	5	005
Increments of	25	025
Increments of	100	100

TO ORDER THIS TYPE 1115 LINE ASSEMBLY:

1. From **Table A**...select PROCESS CONNECTION SIZE (e.g., 02 for $\frac{1}{4}$ " male NPT)
2. From **Table B**...select TYPE (e.g., 1115A for stainless steel armored)
3. From **Table C**...select INSTRUMENT CONNECTION SIZE (e.g., 25 for $\frac{1}{4}$ " female NPT)
4. From **Table D**...determine DESIRED LENGTH (e.g., 005 for five foot long assembly)
5. Insert . . . WS at the end of completed product code.

Coded order: 02-1115A-25-005-WS

BIMETAL THERMOMETERS

Introduction	53
Adjustable Angle	54
3" Dial Size – Rigid Forms.....	55
5" Dial Size – Rigid Forms.....	56
3" Dial Size – Heavy Duty.....	57
Pocket Bimetal	58
Sanitary Wells, Conversion Kit, Duct Flange	59
Thermowells	61-63



RANGE

The maximum operating pressure should not exceed 75% of the full-scale range. The normal operating range should be in the middle half of the range (between 25% and 75% of the full-scale range); whenever possible.

DIAL SIZE

Select a dial size that allows you to comfortably read the dial from the normal distance when installed.

ACCURACY

All Weksler BiMetal Thermometers have an accuracy of $\pm 1\%$ of the full-scale range. For accurate readings stem must be immersed at least 2 inches in liquids and 4 inches in gases.

UNDER/OVER RANGE PROTECTION

Temporary exposure to temperatures under or over 50% of the full-scale range will not impair accuracy (up to 500°F or 260°C maximum).

CASE ASSEMBLY

The case, bezel, stem and fittings are stainless steel (300 series). The head assembly is sealed to exclude dirt, dust and moisture on 3" and 5" dial sizes, all joints are welded.

DIALS

Dials are white with clear black graduations and numerals and are easy to read.

FACE

A gasketed glass window is standard on 3" and 5" dial sizes. Where breakage is a concern, a plastic or shatterproof glass window is optional at extra cost. On 1" and 2" dial sizes a plastic window is standard (no options available). Plastic windows are not suitable where head temperature exceeds 150°F (65°C).

EXTERNAL ADJUSTMENT

An external adjustment at the rear of the 3" and 5" case permits adjustment at a specific point or pointer repositioning during calibration check.

VIBRATION AND SHOCK

If present, use of either a heavy duty bimetal, MIL SPEC Bimetal or a remote mounted gas actuated thermometer is recommended.

HIGH PRESSURE OR CORROSIVE APPLICATIONS

In these applications, use of a separable thermowell is recommended. In addition to protecting the thermometer, thermowells facilitate removal of the thermometer without having to shut down the system.

STANDARD RANGES

- All Stainless Steel Construction
- External Recalibration Adjustment
- White dial with black markings
- Accurate to ±1% of Scale Range
- Gasketed Glass Face
- Case is sealed to exclude dirt, dust and moisture
- 3" and 5" dial sizes
- Angularly adjustable frame permits positioning of dial to accommodate viewing requirements

3" AND 5" DIAL SIZE CATALOG NUMBERS

STEM LENGTH	FIXED THREAD		UNION CONNECTED	
	3"	5"	3"	5"
2½"	CF02	AF02	CU02	AU02
4"	CF04	AF04	CU04	AU04
6"	CF06	AF06	CU06	AU06
9"	CF09	AF09	CU09	AU09
12"	CF12	AF12	CU12	AU12
15"	CF15	AF15	CU15	AU15
18"	CF18	AF18	CU18	AU18
24"	CF24	AF24	CU24	AU24

NOTE: Union connected types must be used with thermowells, longer length available on special order.

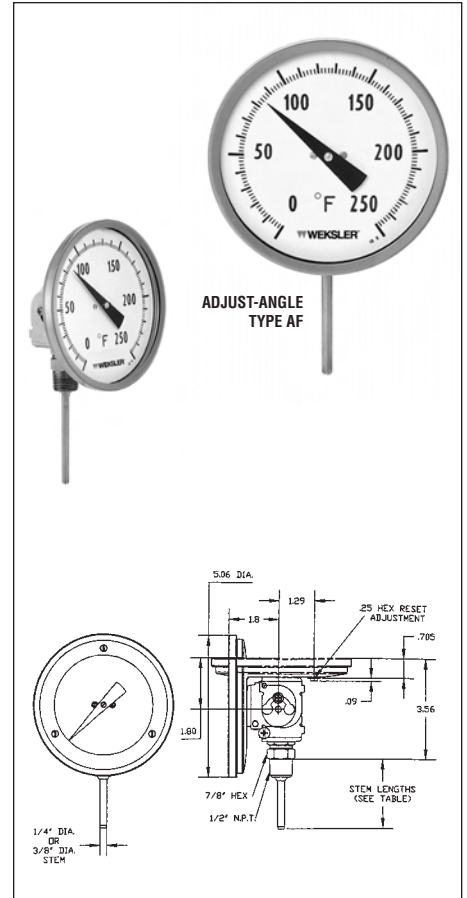

STANDARD RANGES

CODE	Fahrenheit
FC	-80 to 120°F
FE	-40 to 120°F
FG	0 to 150°F
FJ	0 to 200°F
FL	0 to 250°F
FM	30 to 240°F
FN	30 to 130°F †
FR	50 to 300°F
FS	50 to 400°F
FT	50 to 550°F
FX	150 to 750°F †
FY	200 to 1000°F* †
Celsius	
CD	-50 to 50°C
CJ	0 to 100°C
CM	-10 to 110°C
CN	0 to 50°C †
CR	0 to 150°C
CS	0 to 200°C
CU	0 to 300°C
CX	50 to 450°C †
CY	100 to 550°C* †

CODE	DUAL SCALE	
	Fahrenheit (on outside)	Celsius (on inside)
DE	-40/120°F and	-40/50°C
DF	40/160°F and	-40/70°C
DN	30/130°F and	0/55°C †
DJ	0/200°F and	-20/94°C
DL	0/250°F and	-20/120°C
DR	50/300°F and	10/150°C
DS	50/400°F and	10/200°C
DT	50/550°F and	10/290°C
DX	100/800°F* and	40/430°C †
DY	200/1,000°F and	100/550°C* †

*Not recommended for continuous service above 800°F (425°C). For such temperatures see pg. 63.
†Minimum stem length for these ranges 4".

**SEPARABLE THERMOWELLS AVAILABLE
SEE PAGES 59 - 63**

OPTIONAL FEATURES	
CODE	Description
EL	Liquid Filling for Catalog No's AF, 3A, 5A only
PD	Plastic Window
SG	Shatter Proof Glass
NN	Paper Tag
NH	Stainless Steel Tag
DM	Dial Markings
C4	Calibration Certificate

HOW TO ORDER

A F 0 6 4 4 F M X

1. Basic 4-digit Catalog No. From Table Above _____
2. Stem Diameter: "4" = .250"O.D. (Standard); "5" = .375"O.D. (Extra Cost) _____
3. Thread Size: "4" = ½ NPT Male (AF Series); "U" = ½ NPT Male Swivel Nut (AU Series) _____
4. 2 Digit Range Code from Range Tables Above _____
5. Option(s): "X" = None Required; "9" = Option(s) Required (Extra Cost) _____

If option(s) are required specify: Plastic Face, Shatterproof Glass Face, Paper Tag, Stainless Steel Tag

STANDARD FEATURES

- All Stainless Steel Construction
- External Recalibration Adjustment
- White dial with black markings
- Accurate to ±1% of Scale Range
- Gasketed Glass Face
- Case is sealed to exclude dirt, dust and moisture
- 3" dial size

CATALOG NUMBERS*		
STEM LENGTH	90° BACK ANGLE FORM	STRAIGHT FORM
2½"	3A02	3S02
4"	3A04	3S04
6"	3A06	3S06
9"	3A09	3S09
12"	3A12	3S12
15"	3A15	3S15
18"	3A18	3S18
24"	3A24	3S24

Longer stem lengths available on special order.

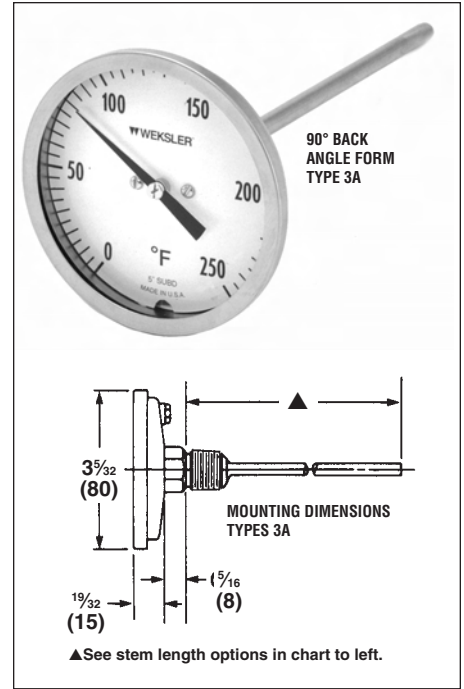

STANDARD RANGES

CODE	Fahrenheit
FC	-80 to 120°F
FE	-40 to 120°F
FG	0 to 150°F
FJ	0 to 200°F
FL	0 to 250°F
FM	30 to 240°F
FN	30 to 130°F †
FR	50 to 300°F
FS	50 to 400°F
FT	50 to 550°F
FX	150 to 750°F †
FY	200 to 1000°F* †

CODE	Celsius
CD	-50 to 50°C
CJ	0 to 100°C
CM	-10 to 110°C
CN	0 to 50°C †
CR	0 to 150°C
CS	0 to 200°C
CU	0 to 300°C
CX	50 to 450°C †
CY	100 to 550°C* †

CODE	DUAL SCALE	
	Fahrenheit (on outside)	Celsius (on inside)
DE	-40/120°F	and -40/50°C
DF	40/160°F	and -40/70°C
DN	30/130°F	and 0/55°C †
DJ	0/200°F	and -20/94°C
DL	0/250°F	and -20/120°C
DR	50/300°F	and 10/150°C
DS	50/400°F	and 10/200°C
DT	50/550°F	and 10/290°C
DX	100/800°F*	and 40/430°C †
DY	200/1,000°F	and 100/550°C* †

*Not recommended for continuous service above 800°F (425°C). For such temperatures see pg. 63.
 †Minimum stem length for these ranges 4".

OPTIONAL FEATURES	
CODE	Description
EL	Liquid Filling for Catalog No's AF, 3A, 5A only
PD	Plastic Window
SG	Shatter Proof Glass
NN	Paper Tag
NH	Stainless Steel Tag
DM	Dial Markings
C4	Calibration Certificate

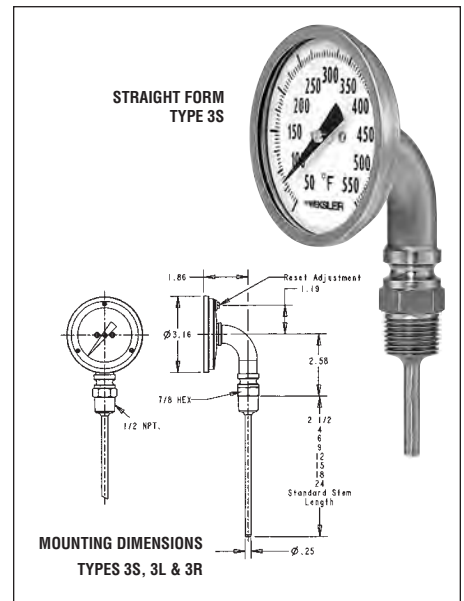

**SEPARABLE THERMOWELLS AVAILABLE
SEE PAGES 59 - 63**

HOW TO ORDER

3 S 0 4 4 4 D R X

1. Basic 4-digit Catalog No. From Table Above _____
2. Stem Diameter: "4" = .250" O.D. (Standard); "5" = .375" O.D. (Extra Cost) _____
3. Thread Size: "4" = 1/2 NPT Male; "U" = 1/4 NPT Male (Extra Cost) _____
4. 2 Digit Range Code from Range Tables Above _____
5. Option(s): "X" = Non Required Option(s) Required (Extra Cost) Select code from above table _____

STANDARD FEATURES

- All Stainless Steel Construction
- External Recalibration Adjustment
- White dial with black markings
- Accurate to ±1% of Scale Range
- Gasketed Glass Face
- Case is sealed to exclude dirt, dust and moisture
- 5" dial size

CATALOG NUMBERS*		
STEM LENGTH	90° BACK ANGLE FORM	STRAIGHT FORM
2½"	5A02	5S02
4"	5A04	5S04
6"	5A06	5S06
9"	5A09	5S09
12"	5A12	5S12
15"	5A15	5S15
18"	5A18	5S18
24"	5A24	5S24

Longer stem lengths available on special order

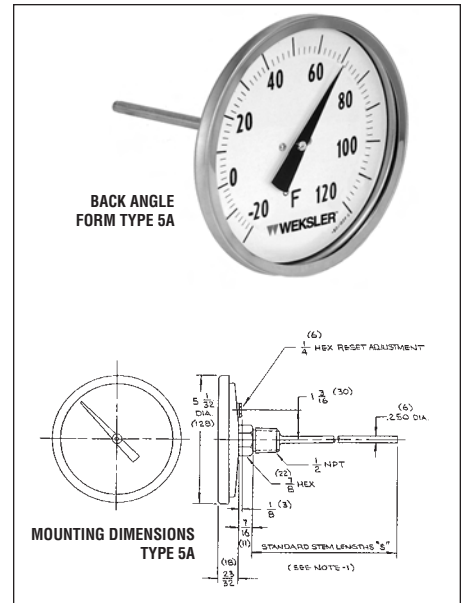

STANDARD RANGES

CODE	Fahrenheit
FC	-80 to 120°F
FE	-40 to 120°F
FG	0 to 150°F
FJ	0 to 200°F
FL	0 to 250°F
FM	30 to 240°F
FN	30 to 130°F †
FR	50 to 300°F
FS	50 to 400°F
FT	50 to 550°F
FX	150 to 750°F †
FY	200 to 1000°F* †

CODE	Celsius
CD	-50 to 50°C
CJ	0 to 100°C
CM	-10 to 110°C
CN	0 to 50°C
CR	0 to 150°C
CS	0 to 200°C
CU	0 to 300°C
CX	50 to 450°C †
CY	100 to 550°C* †

CODE	DUAL SCALE	
	Fahrenheit (on outside)	Celsius (on inside)
DE	-40/120°F	and -40/50°C
DF	40/160°F	and -40/70°C
DN	30/130°F	and 0/55°C †
DJ	-0/200°F	and -20/94°C
DL	0/250°F	and -20/120°C
DR	50/300°F	and 10/150°C
DS	50/400°F	and 10/200°C
DT	50/550°F	and 10/290°C
DX	100/800°F*	and 40/430°C †
DY	200/1,000°F	and 100/550°C* †

*Not recommended for continuous service above 800°F (425°C). For such temperatures see pg. 63.
 †Minimum stem length for these ranges 4".

CODE	DESCRIPTION
EL	Liquid Filling for Catalog No's AF, 3A, 5A only
PD	Plastic Window
SG	Shatter Proof Glass
NN	Paper Tag
NH	Stainless Steel Tag
DM	Dial Markings
C4	Calibration Certificate

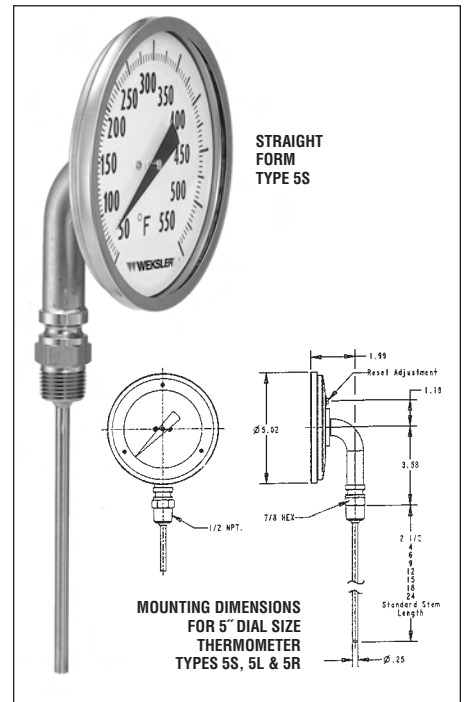

**SEPARABLE THERMOWELLS AVAILABLE
SEE PAGES 59 - 63**

HOW TO ORDER

5 A 0 6 4 4 F J X

1. Basic 4-digit Catalog No. From Table Above _____
2. Stem Diameter: "4" = .250" O.D. (Standard); "5" = .375" O.D. (Extra Cost) _____
3. Thread Size: "4" = 1/2 NPT Male; "U" = 1/4 NPT Male (Extra Cost) _____
4. 2 Digit Range Code from Range Tables Above _____
5. Option(s): "X" = Non Required Option(s) Required (Extra Cost) Select code from above table _____

STANDARD FEATURES

- Shock and Vibration Resistant
- Stainless Steel Construction
- Plastic Crystal
- Dished Anti-Parallax Dial for Easy Reading
- External Recalibration Adjustment at Rear of Case
- Accurate to 1% of Scale Range (when tested without well)
- Interchangeable with 5" Scale Size "Submarine" Thermometers Having Same Stem Length
- 3/4"-28 UN2A Union Connection Assembly Must be used with Well (or Bushing)

STEM LENGTH	CATALOG NUMBERS	
	90° BACK ANGLE FORM	STRAIGHT FORM
2"	H3A2	H3S2
4"	H3A4	H3S4
6"	H3A6	H3S6

NOTE: A minimum of 2" insertion (immersion) is required for accurate readings and proper response.

CODE	Fahrenheit
D	-40 to 120°F in 2° divs.*
H	0 to 200°F in 2° divs.
L	20 to 240°F in 2° divs.
P	50 to 300°F in 2° divs.
Q	50 to 400°F in 5° divs.
R	50 to 500°F in 5° divs.
S	50 to 750°F in 10° divs.
Celsius	
1	-50 to 50°C in 1° divs.*
2	-10 to 110°C in 1° divs.
5	0 to 150°C in 2° divs.
6	0 to 200°C in 2° divs.
8	0 to 300°C in 5° divs.

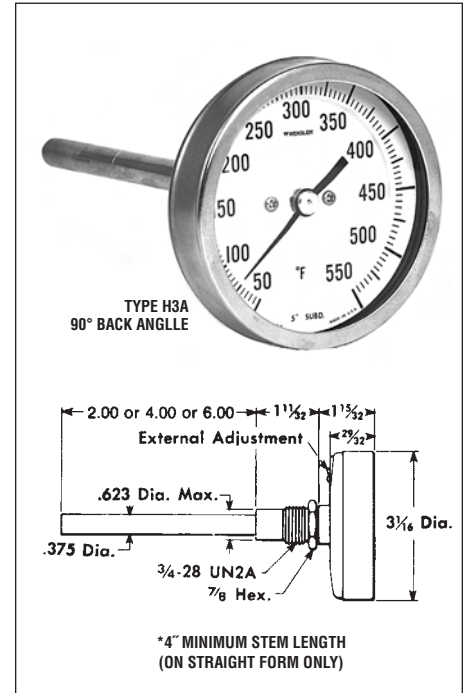

HOW TO ORDER

H 3 S 4 H

1. Basic 4-digit Catalog No. _____
2. Range Code _____

**THERMOWELLS FOR HEAVY DUTY BIMETAL THERMOMETERS
.385" BORE – 3/4-28" FEMALE THREAD (INTERNAL)**

THREADED TYPE – 3/4-14 NPT MALE

THERMOMETER STEM LENGTH	WELL LENGTH (OVERALL)	CATALOG NO.		
		NAVAL BRASS	304 SS	MONEL
2"	3 1/4"	W3N1	W3G1	W3M1
4"	5 1/4"	W5N1	W5G1	W5M1
6"	7 1/4"	W7N1	W7G1	W7M1

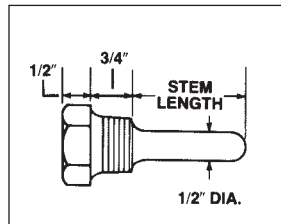

WELDING/BRAZING TYPE – 3/4 SOCKET WELD

THERMOMETER STEM LENGTH	WELL LENGTH (OVERALL)	CATALOG NO.		
		PHOS. BRONZE	COPPER NICKEL	316 SS
2"	3 5/16"	W4R4	W4C4	W4F4
4"	5 5/16"	W6R5	W6C5	W6F5
6"	7 5/16"	W8R6	W8C6	W8F6

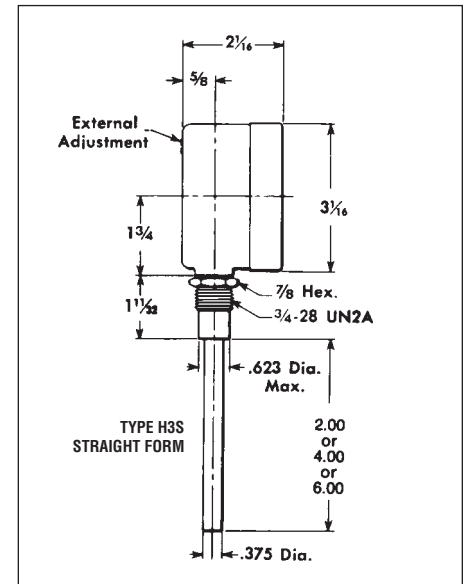
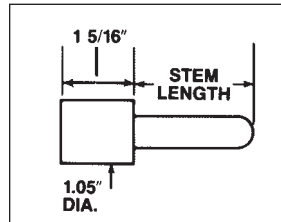

To Order: Specify 4 digit catalog no. from above tables

STANDARD FEATURES

- 1" dial
- 5" stem length
- .142" stem diameter
- Complete with pocket case and clip
- Standard with plastic crystal and recalibration feature

CATALOG NUMBER	STANDARD RANGES
1R05A	-40 to 160°F in 2° divs.
1R05B	25 to 125°F in 1° divs.
1R05C	0 to 220°F in 2° divs.
1R05D	50 to 550°F in 5° divs.
1R05E	-50 to 100°C in 2° divs.
1R05F	-10 to 110°C in 2° divs.
1R05G	0 to 150°C in 2° divs.
1R05H	0 to 250°C in 5° divs.

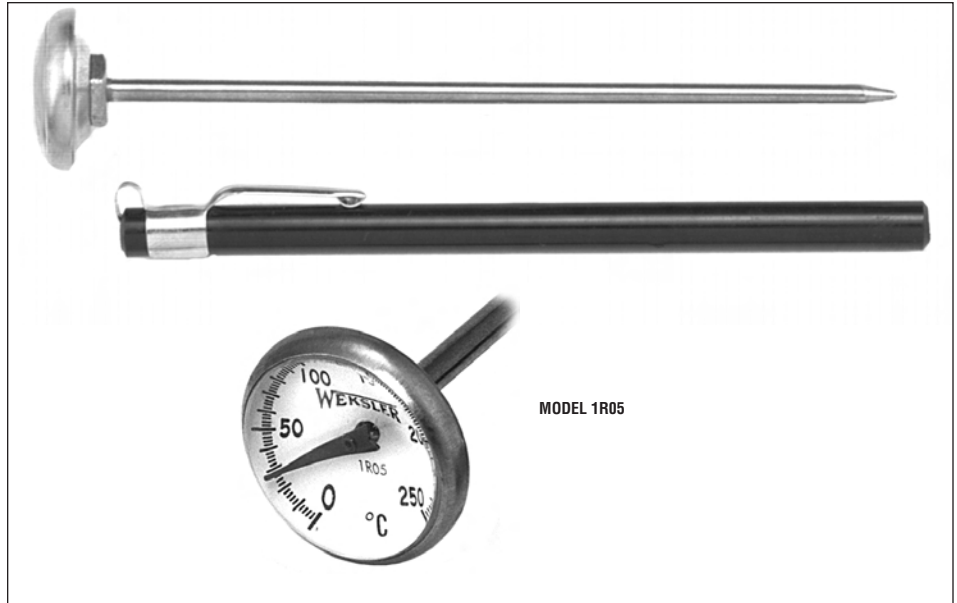

MODEL 1R05

STANDARD FEATURES

- 2" dial
- All Stainless Steel Construction
- Accurate to ±1% of Scale Range
- Dual Scale (Both °F and °C) Ranges

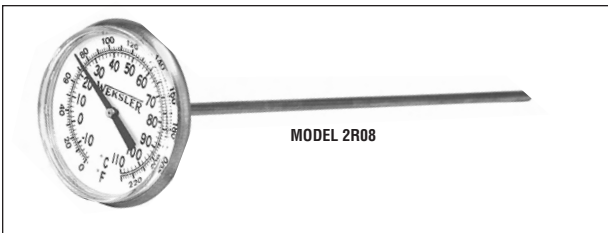

MODEL 2R08



MODEL 2T02

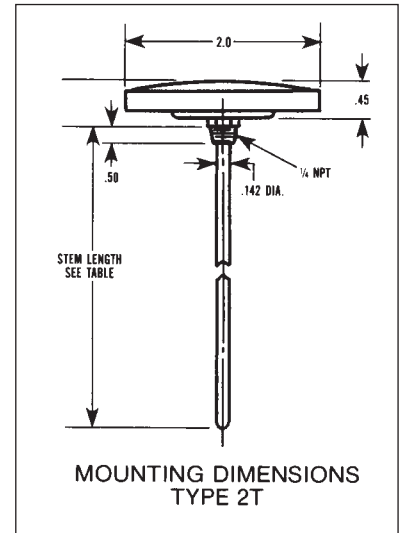

MOUNTING CLIP FOR 1" and 2" PN TPC

CATALOG NUMBER	DUAL SCALE (BOTH °F AND °C)		TYPE
	FAHRENHEIT ON OUTER – CELSIUS ON INNER SCALE		
2R08A	-40 to 160°F in 2° divs.	and -40 to 70°C in 2° divs.	8" Plain Stem With Recalibration Feature
2R08B	25 to 125°F in 1° divs.	and -5 to 50°C in 1° divs.	
2R08J	0 to 180°F in 2° divs.	and -18 to 83°C in 1° divs.	
2R08C	0 to 220°F in 1° divs.	and -10 to 110°C in 2° divs.	
2R08K	50 to 400°F in 5° divs.	and 10 to 106°C in 2° divs.	
2R08D	50 to 550°F in 5° divs.	and 10 to 290°C in 5° divs.	
2T02A	-40 to 160°F in 2° divs.	and -40 to 70°C in 2° divs.	2½" Stem ¼ NPT Fixed Thread
2T02C	0 to 220°F in 2° divs.	and -10 to 110°C in 2° divs.	
2T04A	-40 to 160°F in 2° divs.	and -40 to 70°C in 2° divs.	4" Stem ¼ NPT Fixed Thread
2T04B	25 to 125°F in 1° divs.	and -5 to 50°C in 1° divs.	
2T04C	0 to 220°F in 2° divs.	and -10 to 110°C in 2° divs.	

HOW TO ORDER

Specify 5 digit catalog number from above tables

THERMOWELL MEETS USDA, FDA AND 3A SANITARY STANDARD 09-08

Sanitary instruments are designed for applications in the food, dairy, pharmaceutical, cosmetic, and beverage industries. The standard Tri-clamp fittings have no exposed threads and prevent the process from entering the instruments.

CATALOG NO.	CLAMP SIZE	STEM LENGTH	'U' DIMENSION
D8J4	1 1/2"	4"	2 1/2"
D8J6	1 1/2"	6"	4 1/2"
D9J4	2"	4"	2 1/2"
D9J6	2"	6"	4 1/2"



HOW TO ORDER

Order thermowell by 4 digit catalog number from table above.

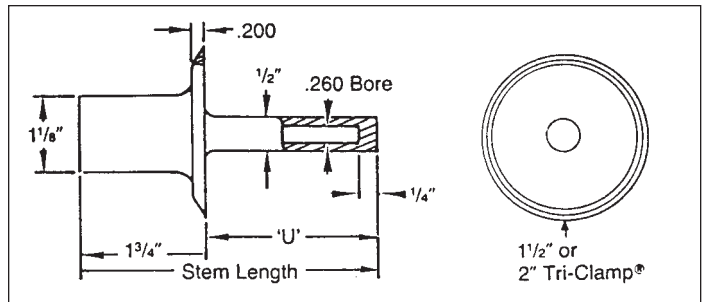

BIMETAL TO INDUSTRIAL WELL CONVERSION KIT

With this kit, an existing Industrial Thermometer Well can be used to accept a Bimetal Dial thermometer. Kit consisting of a liner, an adaptor nut, a spring and heat conducting medium.

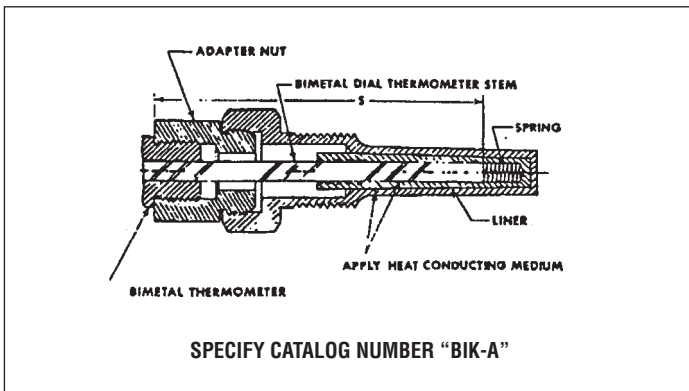

1/2 NPT FLANGE

Satin finish chrome plated brass. For use in air ducts, dryers, ovens, etc.

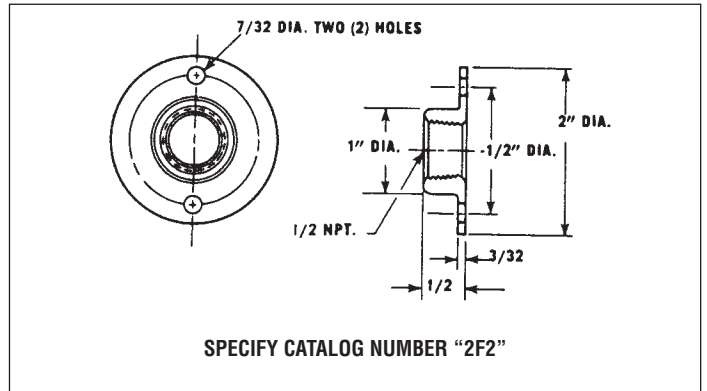

**FOR INDUSTRIAL BIMETAL THERMOMETERS
WITH .250" DIAMETER ELEMENTS**

- .385" bore available for use with instruments with .375" diameter elements
- All Weksler standard thermowells are bored from solid bar stock

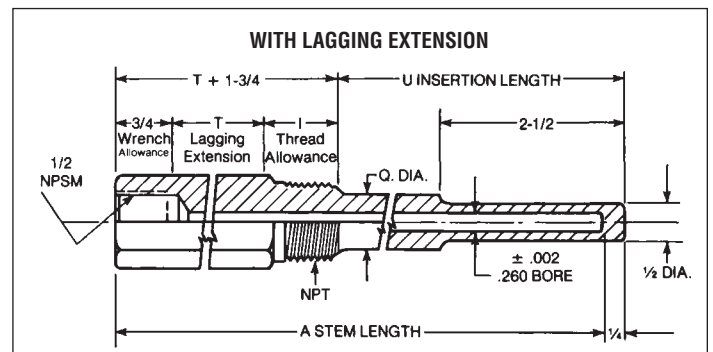
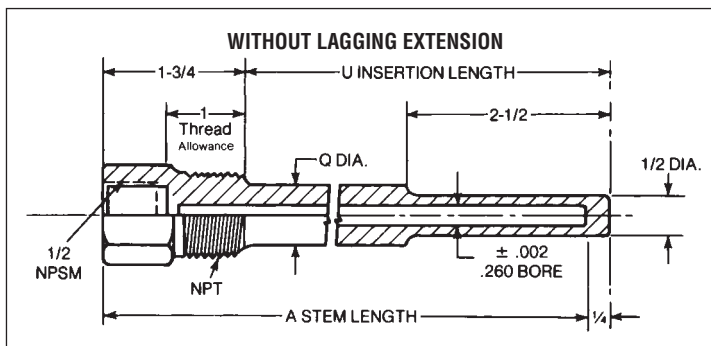
3/4 NPT – CATALOG NUMBERS

A	U	Q	BRASS	STEEL	304 SS	316 SS
4	2½	—	S3B4	S3S4	S3G4	S3J4
6	4½	¾	S3B6	S3S6	S3G6	S3J6
9	7½	¾	S3B9	S3S9	S3G9	S3J9
12	10½	¾	S3B2	S3S2	S3G2	S3J2
15	13½	¾	S3B5	S3S5	S3G5	S3J5
18	16½	¾	S3B8	S3S8	S3G8	S3J8
24	22½	¾	S3BT	S3ST	S3GT	S3JT

3/4 NPT – CATALOG NUMBERS

A	U	T	Q	BRASS	304 STEEL	316 SS	SS
6	2½	2	—	L3B6	L3S6	L3G6	L3J6
9	4½	3	¾	L3B9	L3S9	L3G9	L3J9
12	7½	3	¾	L3B2	L3S2	L3G2	L3J2
15	10½	3	¾	L3B5	L3S5	L3G5	L3J5
18	13½	3	¾	L3B8	L3S8	L3G8	L3J8
24	19½	3	¾	L3BT	L3ST	L3GT	L3JT

1 NPT – CATALOG NUMBERS

A	U	Q	BRASS	STEEL	304 SS	316 SS
4	2½	—	S4B4	S4S4	S4G4	S4J4
6	4½	7/8	S4B6	S4S6	S4G6	S4J6
9	7½	7/8	S4B9	S4S9	S4G9	S4J9
12	10½	7/8	S4B2	S4S2	S4G2	S4J2
15	13½	7/8	S4B5	S4S5	S4G5	S4J5
18	16½	7/8	S4B8	S4S8	S4G8	S4J8
24	22½	7/8	S4BT	S4ST	S4GT	S4JT

1 NPT – CATALOG NUMBERS

A	U	T	Q	BRASS	304 STEEL	316 SS	SS
6	2½	2	—	L4B6	L4S6	L4G6	L4J6
9	4½	3	7/8	L4B9	L4S9	L4G9	L4J9
12	7½	3	7/8	L4B2	L4S2	L4G2	L4J2
15	10½	3	7/8	L4B5	L4S5	L4G5	L4J5
18	13½	3	7/8	L4B8	L4S8	L4G8	L4J8
24	19½	3	7/8	L4BT	L4ST	L4GT	L4JT

Brass wells are not recommended for installations involving high pressures and/or temperatures over 400°F.

Brass cap and chain available to keep bore clean when not in use.

.260" bore standard. If .385" bore is required:

(1) Add the letter K at the end of the catalog no.;

(2) "Q" diameter is changed to 49/64" along entire length of insertion ("U" dimension).

For pressure – temperature rating use Table 1 on page 89.

NOTE: 2½" STEM THERMOMETERS USE SPECIAL LIMITED SPACE WELLS.

LIMITED SPACE WELLS

Fits Weksler 3" and 5" bimetal thermometers with 2½" stem length. It is recommended that these be used only when space is such a critical factor that wells for 4" stem length bi-metals cannot be utilized.

IMPORTANT NOTE: The above limited space thermowells should not be used with Weksler 3" or 5" bimetals with the following ranges: 25/125°F, -40/120°F, 0/150°F, 50/500°F, 150/750°F, 0/50°C, -50/50°C, 0/300°C and 100/400°C. These ranges must use thermometers with 4" minimum stem length.

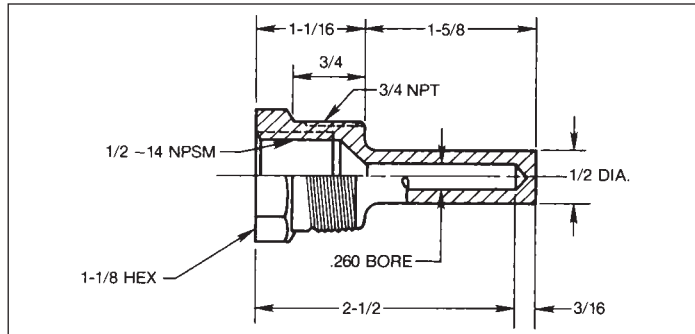

CATALOG NUMBERS				
	BRASS	STEEL	304 SS	316 SS
3/4 NPT	S3B1	S3S1	S3G1	S3J1
1 NPT	S4B1	S4S1	S4G1	S4J1

Brass wells are not recommended for installations involving high pressures and/or temperatures over 400°F.

HEAVY DUTY THREADED WELLS

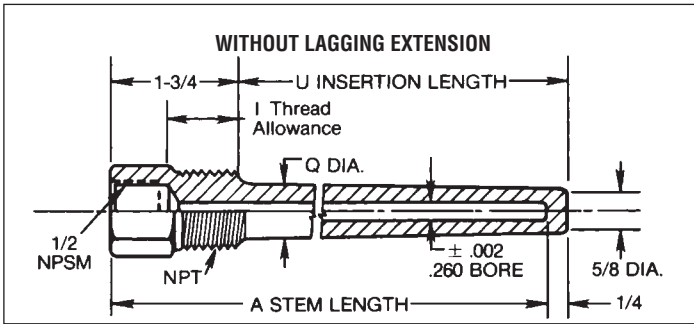

¾ NPT – CATALOG NUMBERS

A	U	Q	STEEL	304 SS	316 SS
4	2½	—	S3S4H	S3G4H	S3J4H
6	4½	⅞	S3S6H	S3G6H	S3J6H
9	7½	⅞	S3S9H	S3G9H	S3J9H
12	10½	⅞	S3S2H	S3G2H	S3J2H
15	13½	⅞	S3S5H	S3G5H	S3J5H
18	16½	⅞	S3S8H	S3G8H	S3J8H
24	22½	⅞	S3STH	S3GTH	S3JTH

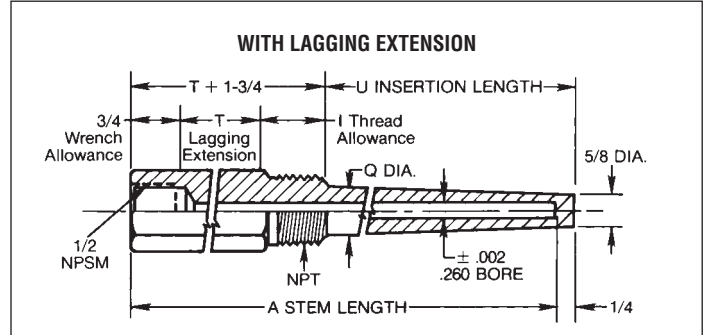

¾ NPT – CATALOG NUMBERS

A	U	T	Q	STEEL	304 SS	316 SS
6	2½	2	⅞	L3S6H	L3G6H	L3J6H
9	4½	3	⅞	L3S9H	L3G9H	L3J9H
12	7½	3	⅞	L3S2H	L3G2H	L3J2H
15	10½	3	⅞	L3S5H	L3G5H	L3J5H
18	13½	3	⅞	L3S8H	L3G8H	L3J8H
24	19½	3	⅞	L3STH	L3GTH	L3JTH

1 NPT – CATALOG NUMBERS

A	U	Q	STEEL	304 SS	316 SS
4	2½	1⅙	S4S4H	S4G4H	S4J4H
6	4½	1⅙	S4S6H	S4G6H	S4J6H
9	7½	1⅙	S4S9H	S4G9H	S4J9H
12	10½	1⅙	S4S2H	S4G2H	S4J2H
15	13½	1⅙	S4S5H	S4G5H	S4J5H
18	16½	1⅙	S4S8H	S4G8H	S4J8H
24	22½	1⅙	S4STH	S4GTH	S4JTH

1 NPT – CATALOG NUMBERS

A	U	T	Q	STEEL	304 SS	316 SS
6	2½	2	1⅙	L4S6H	L4G6H	L4J6H
9	4½	3	1⅙	L4S9H	L4G9H	L4J9H
12	7½	3	1⅙	L4S2H	L4G2H	L4J2H
15	10½	3	1⅙	L4S5H	L4G5H	L4J5H
18	13½	3	1⅙	L4S8H	L4G8H	L4J8H
24	19½	3	1⅙	L4STH	L4GTH	L4JTH

Brass cap and chain available to keep bore clean when not in use.

.260" bore standard. If .385" bore is required:

(1) change the last digit of the catalog no. from H to L;

(2) "Q" diameter will be 1⅙" on all and diameter at the end of taper (bottom of well) will be 49/64".

For pressure and temperature rating use Table 2 on page 89.

NOTE: ALL WEKSLER STANDARD THERMOWELLS ARE BORED FROM SOLID BAR STOCK.

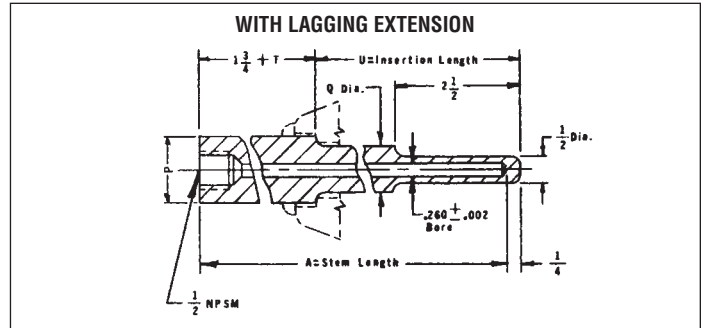
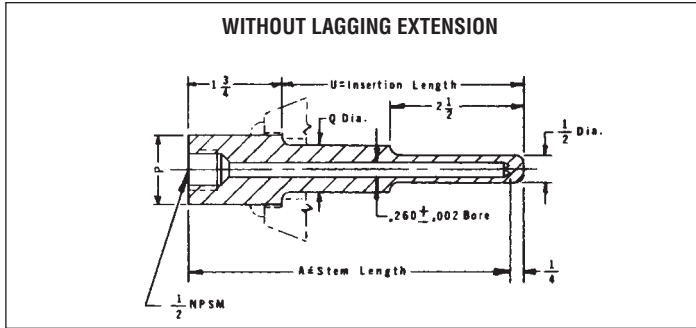

3/4 NPT – CATALOG NUMBERS

A	U	Q	STEEL	304 SS	316 SS
4	2½	½	S5S4	S5G4	S5J4
6	4½	¾	S5S6	S5G6	S5J6
9	7½	¾	S5S9	S5G9	S5J9
12	10½	¾	S5S2	S5G2	S5J2
15	13½	¾	S5S5	S5G5	S5J5
18	16½	¾	S5S8	S5G8	S5J8
24	22½	¾	S5ST	S5GT	S5JT

3/4 NPT – CATALOG NUMBERS

A	U	T	Q	STEEL	304 SS	316 SS
6	2½	2	½	L5S6	L5G6	L5J6
9	4½	3	¾	L5S9	L5G9	L5J9
12	7½	3	¾	L5S2	L5G2	L5J2
15	10½	3	¾	L5S5	L5G5	L5J5
18	13½	3	¾	L5S8	L5G8	L5J8
24	19½	3	¾	L5ST	L5GT	L5JT

1 NPT – CATALOG NUMBERS

A	U	Q	STEEL	304 SS	316 SS
4	2½	½	S6S4	S6G4	S6J4
6	4½	⅞	S6S6	S6G6	S6J6
9	7½	⅞	S6S9	S6G9	S6J9
12	10½	⅞	S6S2	S6G2	S6J2
15	13½	⅞	S6S5	S6G5	S6J5
18	16½	⅞	S6S8	S6G8	S6J8
24	22½	⅞	S6ST	S6GT	S6JT

1 NPT – CATALOG NUMBERS

A	U	T	Q	STEEL	304 SS	316 SS
6	2½	2	½	L6S6	L6G6	L6J6
9	4½	3	⅞	L6S9	L6G9	L6J9
12	7½	3	⅞	L6S2	L6G2	L6J2
15	10½	3	⅞	L6S5	L6G5	L6J5
18	13½	3	⅞	L6S8	L6G8	L6J8
24	19½	3	⅞	L6ST	L6GT	L6JT

*NOMINAL PIPE SIZE ("P" DIMENSION)
¾" Weld Connection = 1.050" Diameter
1" Weld Connection = 1.315" Diameter

Brass cap and chain available to keep bore clean when not in use.
 .260" bore standard. If .385" bore is required:
 (1) add the letter K to the end of the catalog no. ;
 (2) "Q" dimension is changed to 49/64" along entire length of insertion ("U" dimension).
 For pressure and temperature rating use Table below.
NOTE: ALL WEKSLER STANDARD THERMOWELLS ARE BORED FROM SOLID BAR STOCK.

**PRESSURE-TEMPERATURE RATING
 (LBS. PER SQ. INCH)**

(Weld-in Type)

(Heavy Duty Threaded)

TABLE 1

MATERIAL	TEMPERATURE – °F						
	70°	200°	400°	600°	800°	1000°	1200°
Brass 5000	4200	1000	—	—	—	—	—
Carbon Steel	5200	5000	4800	4600	3500	1500	—
A.I.S.I.-304	7000	6200	5600	5400	5200	4500	1650
A.I.S.I.-316	7000	7000	6400	6200	6100	5100	2500
Monel 6500	6000	5400	5300	5200	1500	—	—

TABLE 2

MATERIAL	TEMPERATURE – °F						
	70°	200°	400°	600°	800°	1000°	1200°
Brass	5300	4250	1100	—	—	—	—
Carbon Steel	5950	5750	5450	5250	4000	1750	—
A.I.S.I.-304	7800	7050	6400	6150	6000	5190	1875
A.I.S.I.-316	7800	7800	7250	7100	6950	5800	2720
Monel	7450	6850	6150	6100	5940	1750	—

GLASS THERMOMETERS

Adjustable Angle Glass Thermometers	67
Adjustable Angle Air Duct Thermometers	68
Adjust Angle Digital Thermometers.....	69
Dimensions, Thermowells	70
Navy/Marine Thermometer	71
Economy Glass Thermometer	71

Adjust Angle Thermometer, Mercury Free, Standard Model A935AF5

STANDARD FEATURES

- Mercury Free.
- Molded Valox® – V-shaped black case for ranges up to and including 300°F
- Die cast black aluminum V-shaped case for ranges above 300°F.
- Glass front excludes dust and dirt.
- White aluminum scale with bold black graduations and figures.
- Mercury Free blue liquid in glass with magnifying lens for easy readability.
- Accuracy is $\pm 1\%$ of full scale.
- Easy adjustment permits case and stem to be rotated 360°.
- 3½", 6", 9" & 12" stems available.
- 1¼"-18" NEF swivel nut.

OPTIONS

- Plastic window available for both 7" and 9" scale.
- Aluminum case available for low ranges (300°F and below).
- Lower connect (straight form) and back connect (back angle form) available.

RANGES

	MINOR GRADS	RANGE CODE
FAHRENHEIT		
-40/110F	2°	F1
0/120F	1°	F2
0/160F	2°	F3
30/180F	2°	F4
30/240F	2°	F5
30/300F	5°	F6
50/400F ⁽¹⁾	5°	F7
50/550F ⁽¹⁾	5°	F8
CELSIUS		
-20/45C	1°	C1
0/50C	1°	C2
0/100C	1°	C3
0/160C ⁽¹⁾	2°	C4
0/200C ⁽¹⁾	2°	C5
0/300C ⁽¹⁾	5°	C6
DUAL SCALE		
-40/110F & -40/43C	2°	D1
0/120F & -15/48C	1°	D2
0/160F & -15/70C	2°	D3
30/180F & 0/82C	2°	D4
30/240F & 0/115C	2°	D5
30/300F & 0/150C	5°	D6
50/400F & 10/200C ⁽¹⁾	5°	D7
50/550F & 10/290C ⁽¹⁾	5°	D8

(1) Must be supplied with optional aluminum case.

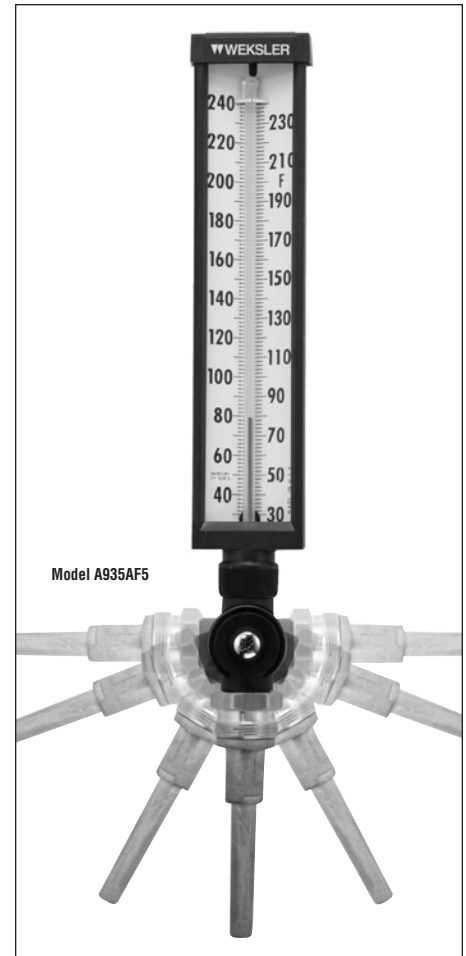

HOW TO ORDER

1. Product Type: **A**
2. Scale Size: 7 = 7" Scale; 9 = 9" Scale **9**
3. Stem Length: 35 = 3½"; 60 = 6"; 90 = 9"; 12 = 12" **35**
4. Connection Location: A = Adjust Angle **A**
5. Range (see table) **F5**
6. Options: AL = Aluminum Case*; PD = Plastic Window **— AL**

*Aluminum case is required for ranges over 300°F

STANDARD FEATURES

- Mercury Free.
- Molded Valox® – V-shaped black case supplied as standard.
- Glass front excludes dust and dirt.
- White aluminum scale with bold black graduations and flanges.
- Mercury Free blue liquid in glass with magnifying lens for easy readability.
- Accuracy is $\pm 1\%$ of full scale.
- Easy adjustment permits case and stem to be rotated 360°.
- 3½", 6", 9" & 12" stems available.
- Protective slotted bulb guard, ¾" diameter aluminum stem and 3" diameter union flange

OPTIONS

- Plastic window available for both 7" and 9" scale.
- Lagging extension.
- Aluminum case.

RANGES

MINOR FAHRENHEIT	RANGE GRADS	CODE
-40/110F	2°	F1
0/120F	1°	F2
0/160F	2°	F3
30/180F	2°	F4
30/240F	2°	F5
CELSIUS		
-20/45C	1°	C1
0/50C	1°	C2
0/100C	1°	C3
DUAL SCALE		
-40/110F & -40/43C	2°	D1
0/120F & -15/48C	1°	D2
0/160F & -15/70C	2°	D3
30/180F & 0/82C	2°	D4
30/240F & 0/115C	2°	D5

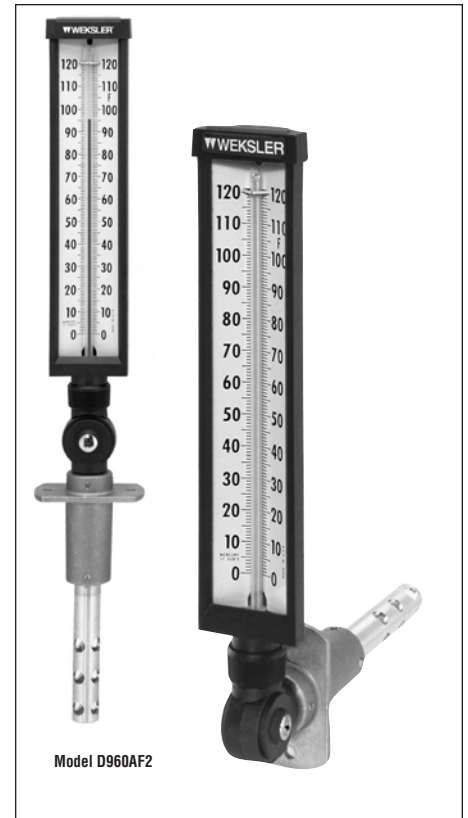
HOW TO ORDER

- D** **9** **60** **A** **F2** — **AL**
1. Product Type:
A = Air Duct Thermometer
 2. Scale Size: 7 = 7" Scale; 9 = 9" Scale
 3. Stem Length: 35 = 3½"; 60 = 6"; 90 = 9"; 12 = 12"
 4. Connection Location: A = Adjust Angle
 5. Range (see table)
 6. Options: PD = Plastic Window

LIGHT-POWERED ADJUSTABLE ANGLE DIGITAL THERMOMETER

The Weksler™ light-powered industrial thermometer offers an environmentally friendly alternative to mercury-filled industrial thermometers. The light-powered industrial thermometer can help reduce inventory requirements with its switchable °F and °C feature, which offers a wide variety of ranges in a single unit (–40/300°F and –40°/150°C). The high impact ABS case can be adjusted for viewing from any angle. Stem lengths of 3½" and 6" are available and are interchangeable with standard glass column industrial thermometers. The light-powered industrial thermometer features a ½" LCD digital display.

SPECIFICATIONS

Switchable Range:
–40/300°F – –40/150°C

Accuracy:
1% of reading or 1° whichever is greater

Display:
½" LCD digits

Resolution:
1/10° between –19.9/199.9°F or 28/93°C

Update Rate:
10 seconds

Recalibration:
Internal potentiometer

Sensor:
Glass passivator thermistor

ACCESSORIES

Thermowells For Adjustable Angle Thermometers:
See page 5

PHYSICAL CHARACTERISTICS

Case:
High-impact ABS

Stem Assemblies, Industrial Glass:
Full conformance with Fed. Spec. GGT-321D

Stem Lengths:
3½" and 6"

Standard Connection:
1¼"-18 NEF Swivel Nut

Weight: 10 oz.

DIMENSIONS

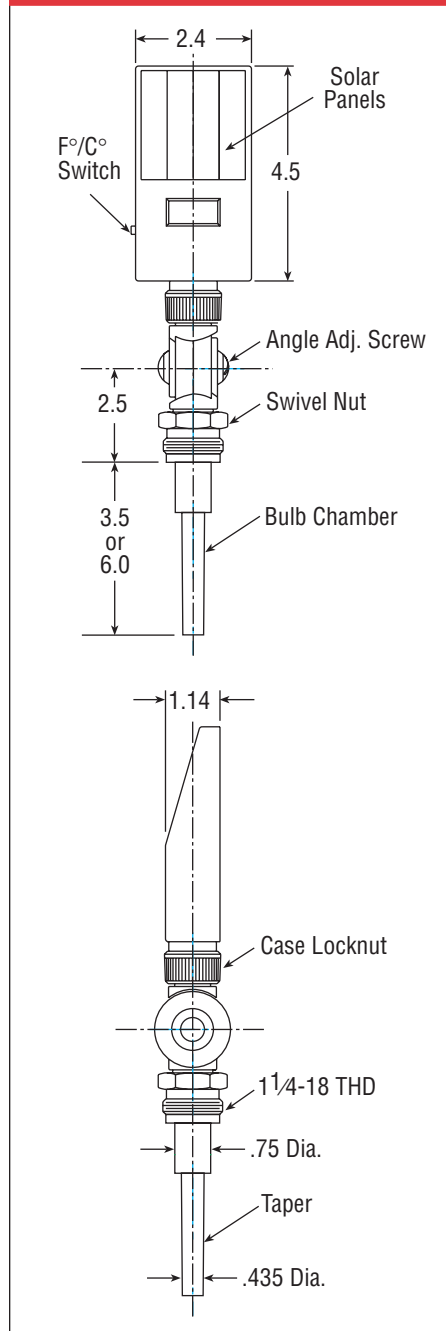

HOW TO ORDER

1. Product Type: **AD** = Adjust Angle Digital Thermometer
2. Stem Length: **35** = 3½"; **60** = 6"
4. Connection Location: **A** = Adjust Angle
5. Range: **FC** = Switchable Range –40/300°F or –40/150°C

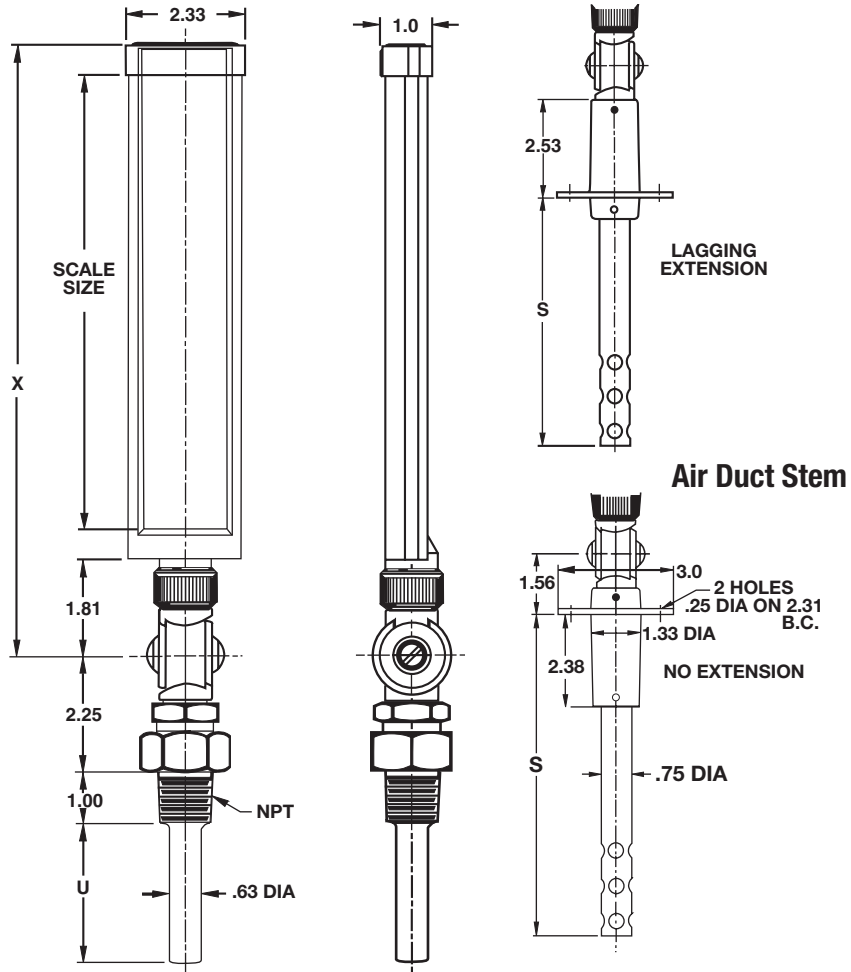

THERMOWELLS FOR ADJUST ANGLE THERMOMETERS

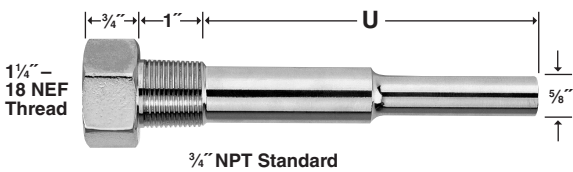

THERMOMETER STEM LENGTH	"U" DIM.	3/4" NPT - CATALOG NUMBER			
		BRASS	STEEL	304 SS	316 SS
3 1/2"	2 1/2"	G1E3D2	G3E3D2	G6E3D2	G4E3D2
6"	5"	G1M3D2	G3M3D2	G6M3D2	G4M3D2
9"	8"	G1S3D2	G3S3D2	G6S3D2	G4S3D2
12"	11"	G1T3D2	G3T3D2	G6T3D2	G4T3D2

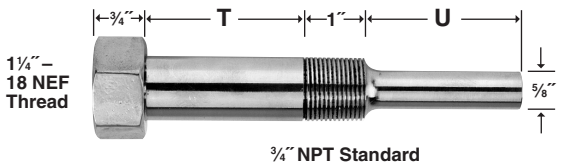

THERMOMETER STEM LENGTH	"T" DIM.	"U" DIM.	3/4" NPT - CATALOG NUMBER			
			BRASS	STEEL	304 SS	316 SS
3 1/2"	1"	1 1/2"	G1E3D2B	G3E3D2B	G6E3D2B	G4E3D2B
6"	2 1/2"	2 1/2"	G1M3D2E	G3M3D2E	G6M3D2E	G4M3D2E
9"	2 1/2"	5 1/2"	G1S3D2E	G3S3D2E	G6S3D2E	G4S3D2E
12"	2 1/2"	8 1/2"	G1T3D2E	G3T3D2E	G6T3D2E	G4T3D2E

Navy/Marine Thermometer
STANDARD FEATURES

- Molded Valox® – V-shaped gray case.
- White aluminum scale with bold black graduations and flanges.
- 2" and 4" stems available.
- 3¼" overall length thermowell (optional) to be used with 2" stem.
- 5¼" overall length thermowell (optional) to be used with 4" stem.
- Red reading with magnifying lens for easy readability.

RANGES

DUAL SCALE	MINOR GRADS	RANGE CODE
-40/110F & -40/43C	2°/2°	D1
20/180F & -5/80C	2°/2°	D0
30/240F & 0/115C	2°/2°	D5
50/400F & 10/200C	5°/2°	D7

PART NUMBERS*

CONNECTION LOCATION	STEM LENGTHS	
	2"	4"
Lower	S520L	S540L
Back	S520R	S540R

*Include range code (above) at end of above # to complete the part number.

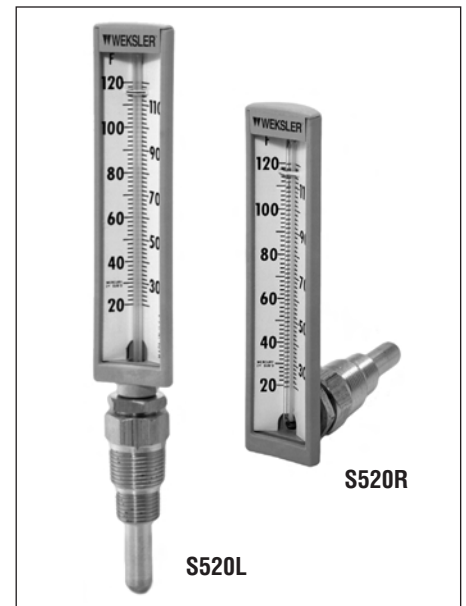
THERMOWELL DIMENSIONS – ¼-28" Female Thread (Internal)

WELL CLASS	STEM LENGTH OF THERMOMETER	OVERALL LENGTH OF WELL	CATALOG #	
			BRASS	304SS
a	2 inch	3¼"	N/A	W3G1
	4 inch	5¼"	N/A	W5G1
c	2 inch	3¼"	W3B3	W3G3
	4 inch	5¼"	W5B3	W5G3

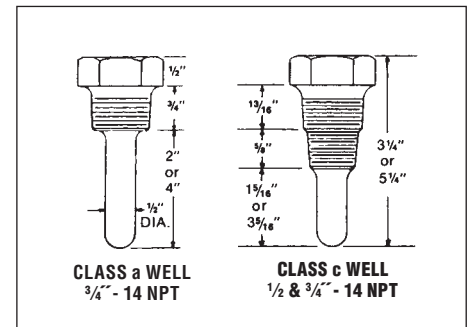
Economy Thermometer
STANDARD FEATURES

- Molded Valox® – V-shaped gray case.
- Red reading spirit filled tube with magnifying lens for easy readability.
- 40/260F and 5/125C is standard range (2°F divisions and 1°C divisions)
- White aluminum scale with bold black graduations and figures.
- 2" stem supplied as standard.
- Supplied standard with removable ½ NPT brass well, 2" length (1.375" insertion).

PART NUMBERS

CONNECTION LOCATION	2" STEM
Lower	E520L
Back	E520R

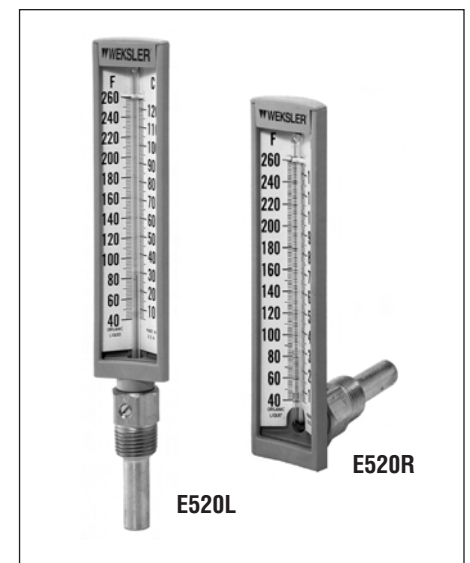



GAS ACTUATED THERMOMETERS

Introduction	75
Remote or Direct Mounted Thermometers.....	76
How to Order Remote or Direct Gas Actuated Thermometers	77-78
Econo Gas Actuated Thermometers	79
How to Order Econo Gas Actuated Thermometers	80-81
Case Styles, Materials, Descriptions, Dimensions....	82-85
Optional Features	86
Thermowells	87
Bulb Fittings	88
Temperature Conversion Table	89

RANGE

The maximum operating pressure should not exceed 75% of the full-scale range. The normal operating range should be in the middle half of the range (between 25% and 75% of the full-scale range); whenever possible.

DIAL SIZE

Select a dial size that allows you to comfortably read the dial from the normal distance when installed.

ACCURACY

All Weksler gas actuated dial thermometers have an accuracy of $\pm 1\%$ of the full-scale range. For accurate readings the entire sensitive portion of the bulb must be fully immersed into the medium being measured.

CASE

A wide variety of case styles and materials are offered. Determine how the thermometer is to be mounted: direct, surface (wall) or flush (in panel). Determine the desired case material: polypropylene, aluminum (black enameled) or stainless steel (300 series).

FACE

A gasketed glass window is standard. Where breakage is a concern, a plastic or shatterproof glass window is optional at extra cost. Plastic windows are not suitable where head temperature exceeds 150°F (65°C).

POINTER

All Weksler gas actuated thermometers have adjustable pointers. This permits pointer repositioning during calibration check or allows maximum precision at a selected point within the scale range.

MOUNTING

Weksler gas actuated thermometers are available in remote mounted types (with capillary tubing between case and sensing bulb) and direct mounted types (sensing bulb is attached directly to case). Remote mounted types allow the temperature to be read at a location remote from the actual temperature source. Remote mounting is also desirable to isolate the head (case, scale, pointer and internal parts) from the damaging effects of shock, vibration or excessive heat that may be present at the temperature source. Direct mounted thermometers are available in "adjust angle" types which allow the head of the thermometer to be positioned for the most desirable viewing angle or rigid (non-adjustable types with fixed bottom or rear connections. Direct mounted units are installed directly on pipes, tanks or other vessels.

BULB TYPES

Weksler gas actuated thermometers are available with various styles of plain bulbs or union connection bulbs. The bulb is the sensing element at the tip of the thermometer that reacts to temperature changes. The entire thermometer including the bulb, head assembly and capillary tubing (on remote types) is filled with an inert nitrogen gas offering fast response and linear dial graduations. Plain bulbs are those without threaded fittings for sensing air temperature or liquid temperatures in open tanks, vats, sinks, etc. Union connected bulbs have threaded swivel nuts that hold the bulb into a bulb fitting such as a thermowell, bushing or flange.

HIGH PRESSURE OR CORROSIVE APPLICATIONS

In these applications, use of a separable thermowell is recommended. In addition to protecting the thermometer, thermowells facilitate removal of the thermometer without having to shut down the system.

STANDARD FEATURES

- Uniformly graduated scales
- Accurate to $\pm 1\%$ of range span
- 3½", 4½", 6" and 8½" dial sizes
- Adjustable pointer
- Fast response
- Inert gas fill – ideal for applications where Mercury is prohibited
- Stainless steel bulb
- Stainless steel (302) interlocked spiral armor over stainless steel (347) capillary tubing (lengths up to 100 ft.)
- Bronze bushed rotary type brass movement – stainless steel movement optional at extra cost
- Rigid or adjustable angle forms

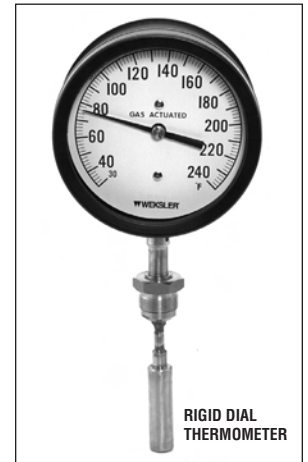
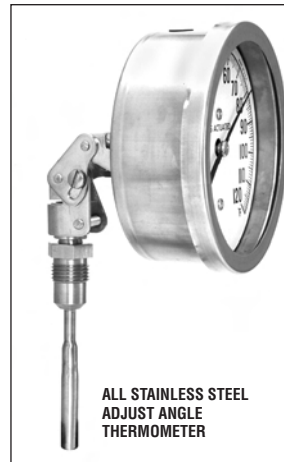
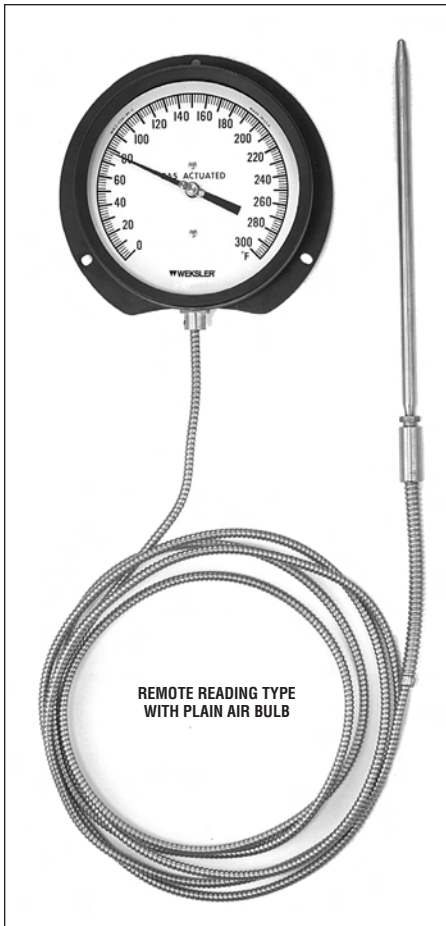
TABLE 1
REMOTE AND DIRECT MOUNTED TYPES

BASE CATALOG NO.	DIAL SIZE	TYPE
313B	3½"	REMOTE MOUNTED
413B	4½"	
613B	6"	
813B	8½"	
453B	4½"	ALL STAINLESS STEEL ADJUSTABLE ANGLE
333B	3½"	ADJUSTABLE ANGLE
433B	4½"	
633B	6"	
833B	8½"	RIGID (NOT ADJUSTABLE)
323B	3½"	
423B	4½"	
623B	6"	
823B	8½"	

STANDARD TYPE "E" CAPILLARY TUBING

0.280" O.D. Stainless Steel Interlocked Spiral (302) Armor Over Stainless Steel Capillary (347)

TABLE 2 – BULB TYPE AND SIZE







FOR ALL MOUNTED TYPES		CODE															
<p>PLAIN BULB FOR AIR TEMPERATURE</p>  <p>Optional Fittings: A16 Bulb Mounting Bracket</p> <p>12" Long .375" Diameter</p>		A															
<p>PLAIN BULB FOR LIQUIDS IN OPENTANKS, VATS, SINKS, ETC.</p>  <p>Optional Fittings: A1 1/2 NPT Compression Fitting A12-2 Set Screw Flange</p> <p>6" Long .50" Diameter</p>		C															
<p>PLAIN BULB WITH 12" BENDABLE EXTENSION</p>  <p>3" x .375" Diameter Bulb</p> <p>3" x .625" Diameter Bulb</p>		1 E															
<p>SLIDING UNION CONNECTION WITH 12" BENDABLE EXTENSION</p>  <p>3" x .375" Diameter Bulb, 1/2 NPT Swivel Nut</p> <p>Optional Fittings: All "K" Series Thermowells 2F2 Flange</p>		3															
<p>SLIDING UNION CONNECTION WITH 12" BENDABLE EXTENSION</p>  <p>3" x .625" Diameter Bulb, 1"-20 NEF-2B Swivel Nut</p> <p>Optional Fittings: All "5F" Series Thermowells All "5F" Series Bushings</p>		N															
<p>3/8" O.D. – 1/2"-14 NPSM Swivel Nut</p> <p>Union Connection (fixed length) Wells, busings or flanges required for installation</p> 	<table border="1"> <thead> <tr> <th>CODE</th> <th>STEM LENGTH</th> <th>FITS WELL*</th> </tr> </thead> <tbody> <tr> <td>4</td> <td>4"</td> <td>4 1/4" O.A.</td> </tr> <tr> <td>6</td> <td>6"</td> <td>6 1/2" O.A.</td> </tr> <tr> <td>9</td> <td>9"</td> <td>9 1/4" O.A.</td> </tr> <tr> <td>2</td> <td>12"</td> <td>12 1/4" O.A.</td> </tr> </tbody> </table> <p>*Uses "K" Series Thermowells (See page)</p>	CODE	STEM LENGTH	FITS WELL*	4	4"	4 1/4" O.A.	6	6"	6 1/2" O.A.	9	9"	9 1/4" O.A.	2	12"	12 1/4" O.A.	
CODE	STEM LENGTH	FITS WELL*															
4	4"	4 1/4" O.A.															
6	6"	6 1/2" O.A.															
9	9"	9 1/4" O.A.															
2	12"	12 1/4" O.A.															
<p>5/8" O.D. – 1"-20 NEF-2B Swivel Nut**</p> 	<table border="1"> <thead> <tr> <th>CODE</th> <th>STEM LENGTH</th> <th>FITS WELL*</th> </tr> </thead> <tbody> <tr> <td>J</td> <td>3 1/2"</td> <td>4 1/4" O.A.</td> </tr> <tr> <td>K</td> <td>6"</td> <td>6 3/4" O.A.</td> </tr> <tr> <td>L</td> <td>9"</td> <td>9 3/4" O.A.</td> </tr> <tr> <td>M</td> <td>12"</td> <td>12 3/4" O.A.</td> </tr> </tbody> </table> <p>**Uses "5F" Series Thermowells "5F" Series Bushings (See page)</p>	CODE	STEM LENGTH	FITS WELL*	J	3 1/2"	4 1/4" O.A.	K	6"	6 3/4" O.A.	L	9"	9 3/4" O.A.	M	12"	12 3/4" O.A.	
CODE	STEM LENGTH	FITS WELL*															
J	3 1/2"	4 1/4" O.A.															
K	6"	6 3/4" O.A.															
L	9"	9 3/4" O.A.															
M	12"	12 3/4" O.A.															

TABLE 3 – CASE STYLES

WALL MOUNTED TYPES	
CODE	CASE TYPE
P	Molded polypropylene, Turret Type Standard – 4 1/2" dial size only.
A	Aluminum, Rear Flange Black Aluminum Bayonet Ring Standard – 3 1/2", 6" dial sizes. Extra cost option – 4 1/2" dial size.
G	Aluminum, Rear Flange Chrome Like Bayonet Ring Standard – 8 1/2" dial size only.
X	Stainless Steel, Rear Flange Stainless Steel Bayonet Ring Extra cost option – 4 1/2" and 8 1/2" dial sizes only.
FLUSH PANEL MOUNTED STYLES	
E	Aluminum Case Black Threaded Front Flange Ring Extra cost option – all dial sizes.
B	Aluminum Case, Semi-Flush Mounting Black Aluminum Bayonet Ring Extra cost option – 3 1/2", 4 1/2", 6" dial sizes.
H	Aluminum Case, Semi-Flush Mounting Chrome like Bayonet Ring Extra cost option – 8 1/2" dial size only.
V	Stainless Steel Case and Bayonet Ring Front Flange – Semi-Flush Mounting Extra cost option – 4 1/2" dial sizes only.
W	Aluminum Case Hinged Front Plastic Bezel Extra cost option – 4 1/2", 6" dial sizes only. (back conn. only)
DIRECT MOUNTED TYPES	
CODE	CASE TYPE
P	Molded polypropylene, Turret Type Standard on 4 1/2" dial size only.
C	Aluminum, Flangeless Black Aluminum Bayonet Ring. Standard on 3 1/2", 4 1/2" and 6" dial sizes.
Y	Stainless Steel, Flangeless Stainless Steel Bayonet Ring Standard on base catalog No. 453B Extra cost option for all other 4 1/2" dial sizes only.

For complete case description and dimensions refer to pages 108-111

TABLE 4

CONNECTION LOCATION CODE	AVAILABILITY			
	ALL SS ADJ. ANGLE	ADJUST ANGLE	RIGID TYPE	REMOTE MOUNT
C = Center Back	•	•		
L = Lower		•	•	•
R = Rear			•	•

TABLE 5

CODE	CASE FEATURE
0	None
2	Flush mounting ring and contact
F	Flush mounting ring only
C	Contact

TABLE 6

CODE	CAPILLARY TYPE
E	Stainless steel armored
Q	PVC coated
X	None required

TABLE 7 – BULB DIMENSIONS

CODE	LENGTH	DIAMETER
NE	12"	3/8 (.375)
GG	6"	1/2 (.50)
CE	3"	3/8 (.375)
CJ	3"	5/8 (.625)
EE	4"	3/8 (.375)
GE	6"	3/8 (.375)
KE	9"	3/8 (.375)
DJ	3 1/2"	5/8 (.625)
GJ	6"	5/8 (.625)
KJ	9"	5/8 (.625)
NJ	12"	5/8 (.625)

TABLE 8

CODE	OPTIONS
0	NONE
D	25" bendable extension
E	30" bendable extension

TABLE 9 – STANDARD RANGES

CODE	FAHRENHEIT	CODE	DUAL (F&C)	CODE	CELCIUS
FA	-100/100	DA	-40/104F & -40/40C	CA	-100/100
FB	-40/110	DB	-40/180F & -40/82C	CB	-40/180
FC	-40/180	DD	-20/120F & -30/50C	CC	-40/110
FD	-20/120	DD	0/120F & -20/50C	CD	0/100
FE	0/100	DE	0/150F & -18/66C	CE	0/120
FF	0/120	DF	0/300F & -20/120C	CF	0/150
FG	0/150	DG	0/500F & -18/260C	CG	0/200
FH	0/200	DH	30/240F & 0/115C	CH	0/300
FI	0/300	DI	50/550F & 10/290C	CI	0/400
FJ	0/400	DJ	200/1000F & 95/540C	CJ	0/500
FK	0/500	DK	400/1200F & 200/650C	CK	200/650
FL	20/240	DL	0/1000F & 18/38C	CM	30/50
FM	30/240	DO	50/750F & 10/399C	CR	30/150
FN	50/550				
FO	50/750				
FP	200/1000				
FQ	400/1200				

TABLE 10

CODE	LENGTH OF CAPILLARY TUBING LENGTHS UP TO 100'
00	None
02	2'
12	12'
1C	100'

HOW TO ORDER

4 5 3 B 4 Y C 0 X EE 0 FA 00 ()

- Specify 4-digit Base Catalog No. from Table 1 _____
- Add Bulb Digit from Table 2 _____
- Add Case Style Digit from Table 3 _____
- Add Connection Location Digit from Table 4 _____
- Add Case Feature Digit from Table 5 (enter "0" if none) _____
- Add Capillary Type Digit from Table 6 (enter "X" if none required) _____
- Add Bulb Dimension Digits from Table 7 _____
- Add Bendable extension Length Digit Options from Table 8 (enter "0" if none required) _____
- Add Range Code Digits from Table 9 _____
- Add Length of Capillary Digit(s) from Table 10 (enter "00" if none required) _____
- Add Optional Feature Code from Page 86 if needed _____

Direct or Remote Mounted Econo Gas-Actuated Thermometers

STANDARD FEATURES

- Uniformly graduated scales
- Accurate to $\pm 1\%$ of range span
- 3 $\frac{1}{2}$ " and 4 $\frac{1}{2}$ " dial sizes
- Adjustable pointer
- Fast response
- Inert gas fill – ideal for applications where Mercury is prohibited
- Copper Bulb, $\frac{1}{2}$ " diameter with brass fittings
- Bronze bushed rotary type brass movement

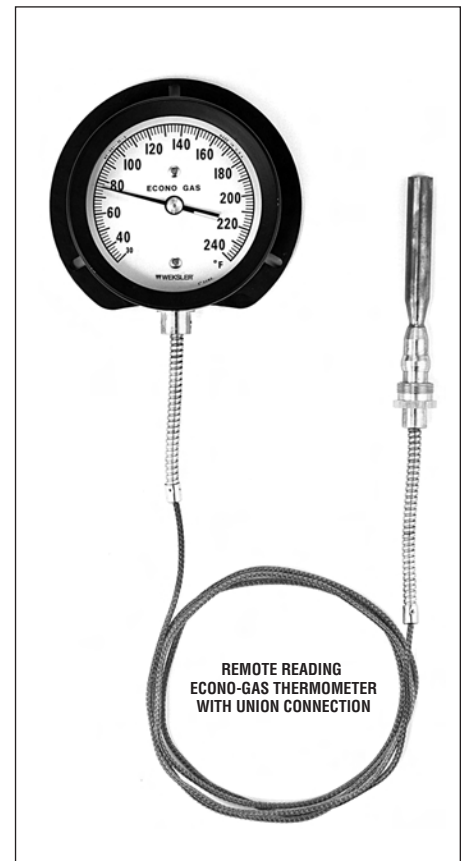
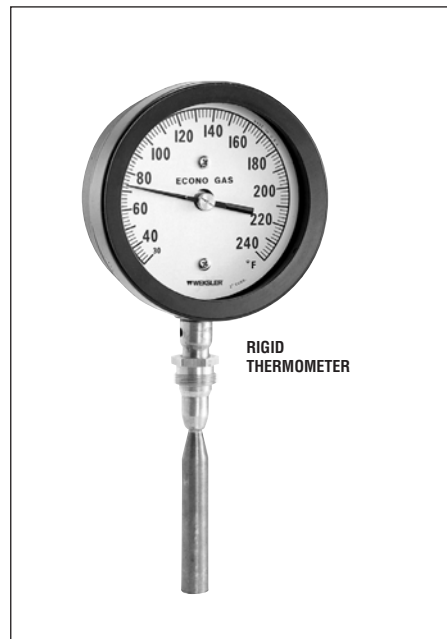
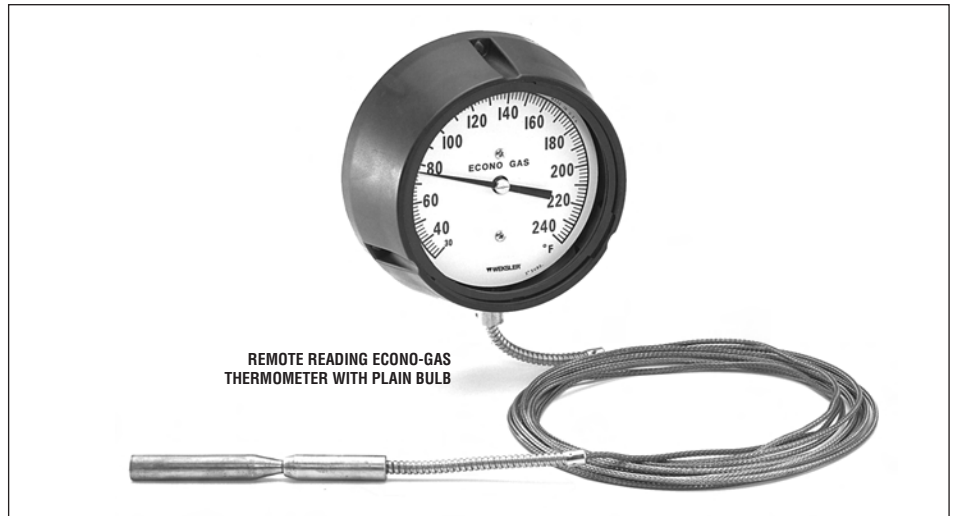

STANDARD TYPE "P" CAPILLARY TUBING



0.125" O.D. Copper Braided Protective Covering Over Copper Capillary
AVAILABLE LENGTHS: 5, 10, 15, 20, 25 or 30 feet.





TABLE 1

REMOTE AND DIRECT MOUNTED TYPES		
BASE CATALOG NO.	DIAL SIZE	TYPE
313E 413E 613E	3½" 4½" 6"	REMOTE MOUNTED
333E 433E	3½" 4½"	ADJUSTABLE ANGLE
323E 423E	3½" 4½"	RIGID (NOT ADJUSTABLE)

TABLE 3 – CASE STYLES

WALL MOUNTED TYPES	
CODE	CASE TYPE
P	Molded polypropylene, Turret Type Standard – 4½" dial size only.
A	Aluminum, Rear Flange Black Aluminum Bayonet Ring Standard – 3½" dial size. Extra cost option – 4½" dial size.
X	Stainless Steel, Rear Flange Stainless Steel Bayonet Ring Extra cost option – 4½" dial size.
FLUSH PANEL MOUNTED STYLES	
E	Aluminum Case Black Threaded Front Flange Ring Extra cost option – all dial sizes.
B	Aluminum Case, Semi-Flush Mounting Black Aluminum Bayonet Ring Extra cost option
V	Stainless Steel Case and Bayonet Ring Front Flange – Semi-Flush Mounting Extra cost option – 4½" dial sizes only.
W	Aluminum Case Hinged Front Plastic Bezel Extra cost option – 4½" dial size.
DIRECT MOUNTED TYPES	
CODE	CASE TYPE
P	Molded polypropylene, Turret Type Standard on 4½" dial size. (Not available in other dial sizes.)
C	Aluminum, Flangeless Black Aluminum Bayonet Ring. Standard on 3½" dial size. Extra cost option for 4½" dial size.
Y	Stainless Steel, Flangeless Stainless Steel Bayonet Ring Extra cost option for 3½" or 4½" dial sizes

TABLE 2 – BULB TYPE AND SIZE
FOR ALL MOUNTED TYPES

PLAIN BULB FOR LIQUIDS IN OPEN TANKS, VATS, SINKS, ETC.		CODE									
	6" Long X .50" Diameter	3.5" C									
Optional Fittings: A1 ½ NPT Compression Fitting A12-2 Set Screw Flange		6" D									
PLAIN BULB WITH 12" BENDABLE EXTENSION											
	3" x .50" Diameter Bulb	E									
SLIDING UNION CONNECTION WITH 12" BENDABLE EXTENSION											
	3.5" x .625" Diameter Bulb, 1"-20 NEF-2B Swivel Nut	N									
Optional Fittings: All "5F" Series Thermowells All "5F" Series Bushings											
DIRECT MOUNTED TYPES											
½" O.D. Bulb – ¾"-24 NS-2 Swivel Nut with Compression Fitting											
Union Connection (fixed length) Wells, bushings or flanges required for installation	<table border="1"> <thead> <tr> <th>CODE</th> <th>STEM LENGTH</th> <th>FITS WELL*</th> </tr> </thead> <tbody> <tr> <td>J</td> <td>3½"</td> <td>4½" O.A.</td> </tr> <tr> <td>K</td> <td>6"</td> <td>6½" O.A.</td> </tr> </tbody> </table>	CODE	STEM LENGTH	FITS WELL*	J	3½"	4½" O.A.	K	6"	6½" O.A.	
CODE	STEM LENGTH	FITS WELL*									
J	3½"	4½" O.A.									
K	6"	6½" O.A.									
	Optional Fittings: "4B Series" Thermowells "4B Series" Bushings All-2 Flange										

For complete case description and dimensions refer to pages 108-111

TABLE 4

CONNECTION LOCATION	AVAILABILITY	
	ADJUST ANGLE	RIGID TYPE
CODE		
L = Lower	•	•
R = Rear		•

TABLE 5

CODE	CASE FEATURE
0	None
2	Flush mounting ring and contact
F	Flush mounting ring only
C	Contact

TABLE 6

CODE	CAPILLARY TYPE
X	None required
P	Copper with braided copper covering

TABLE 7 – BULB DIMENSIONS

CODE	LENGTH	DIAMETER
DG	3 1/2"	1/2 (.50)
GG	6"	1/2 (.50)
CG	3"	1/2 (.50)

TABLE 8

CODE	OPTIONS
0	None
D	25" bendable extension
E	30" bendable extension

TABLE 9 – STANDARD RANGES

CODE	FAHRENHEIT	DIVISIONS
FD	-20 to 120°F	1°
FE	0 to 100°F	1°
FR	30 to 150°F	1°
FM	30 to 240°F	2°
FI	0 to 300°F	2°
CODE	CELSIUS	DIVISIONS
CM	-30 to 50°C	1°
CD	0 to 100°C	1°
CR	30 to 150°C	1°
CODE	DUAL	DIVISIONS
DL	0 to 100°F -18 to 38°C	1°
DH	30 to 240°F 0 to 115°C	2°

TABLE 10

CODE	LENGTH OF CAPILLARY TUBING
00	None
2	2'
12	12'
30*	30'

*Maximum capillary length

HOW TO ORDER

4 3 3 E J V L O X DG O FD 00 ()

1. Specify 4-digit Base Catalog No. from Table 1 _____
2. Add Bulb Digit from Table 2 _____
3. Add Case Style Digit from Table 3 _____
4. Add Connection Location Digit from Table 4 _____
5. Add Case Feature Digit from Table 5 (enter "0" if none) _____
6. Add Capillary Type Digit from Table 6 (enter "X" if none required) _____
7. Add Bulb Dimension Digits from Table 7 _____
8. Add Bendable extension Length Digit Options from Table 8 (enter "0" if none required) _____
9. Add Range Code Digits from Table 9 _____
10. Add Length of Capillary Digit(s) from Table 10 (enter "00" if none required) _____
11. Add Optional Feature Code from Page 112 if needed _____

SURFACE (WALL) OR DIRECT MOUNT TYPES



Snap-in glass retaining ring.
Standard for 4½" remote or direct mount types (except all stainless steel adjust angle).

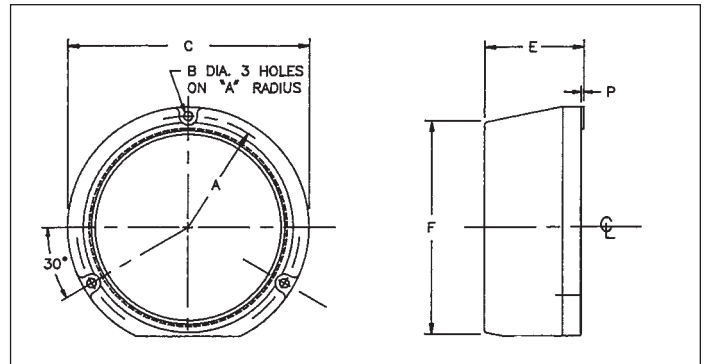

STYLE	DIAL SIZE(S)	MATERIAL
P	4½" Only	Polypropylene

GAUGE SIZE		A	B	C	E	F	P
4½	INCH	2 ¹¹ / ₁₆	¼	5 ¹³ / ₁₆	2 ⁷ / ₁₆	5 ¹ / ₁₆	¼
	MM	68	6	148	62	129	2

FLUSH MOUNTING RING KIT FOR STYLE "P" CASE

CATALOG NUMBER	FOR USE WITH	PANEL CUT-OUT DIAMETER
TR45	4½" "P" Case	5.675"

Kit consists of flush mounting ring plus necessary hardware for mounting (screws, washers, spacer posts).

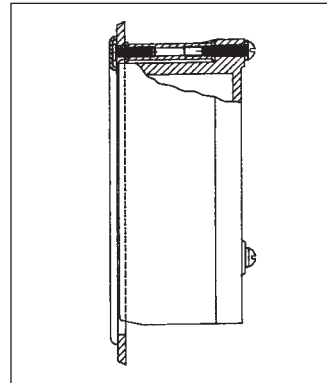

SURFACE (WALL) MOUNT TYPES



Style "A" has bayonet type glass retaining ring.

Style "G" has chrome like slip on glass retaining ring.

Style "A" is standard on 3½" and 6" dial size remote mount thermometers and is optional for 4½" dial size.

Style "G" is standard on 8½" dial size remote mount thermometers.

STYLE	DIAL SIZE(S)	MATERIAL
A	3½" - 4½" - 6"	Aluminum Black Textured Enamel Finish
G	8½" Only	

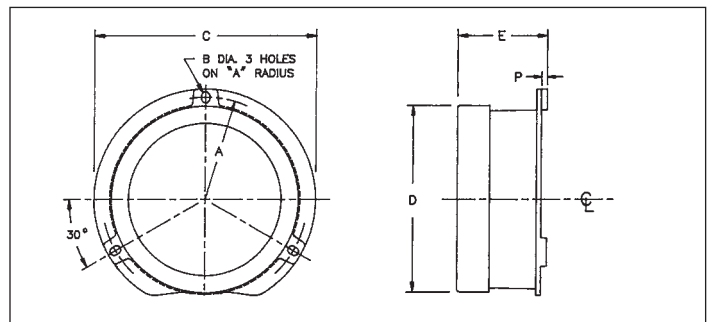

GAUGE SIZE		A	B	C	E	F	P
3½	INCH	2 ¹ / ₈	¾	5	4	2 ¹ / ₁₆	¼
	MM	64	5	127	102	52	3
4½	INCH	2 ¹¹ / ₁₆	¾	5 ⁵ / ₈	4 ⁹ / ₁₆	2 ⁷ / ₁₆	¼
	MM	68	5	149	125	62	3
6	INCH	3 ⁹ / ₁₆	¼	7 ⁵ / ₈	6 ⁷ / ₁₆	2 ¹ / ₂	¼
	MM	90	6	194	164	64	3
8½	INCH	4 ¹³ / ₁₆	¼	10 ¹ / ₄	8 ¹³ / ₁₆	2 ⁵ / ₁₆	¼
	MM	122	6	260	227	59	2

NOTE: ALL DIMENSIONS ARE APPROXIMATE.

SURFACE (WALL) MOUNT TYPES (Cont.)



BAYONET TYPE GLASS RETAINING RING
4 1/2" dial size remote mount thermometers.

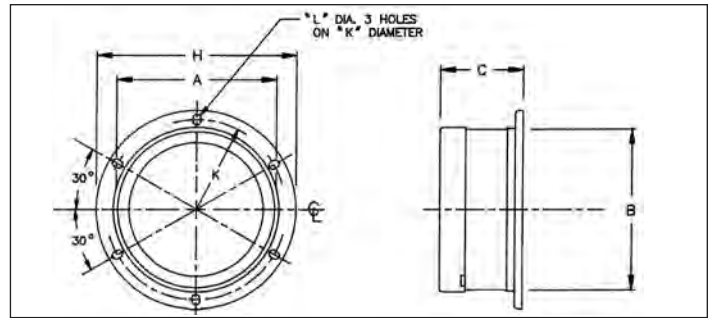

GAUGE SIZE		A	B	C	H	K	L
4 1/2	INCH	4 7/8	4 9/16	2 5/16	6	5 1/16	7/32
	MM	124	116	59	152	144	6

STYLE	DIAL SIZE(S)	MATERIAL
X	4 1/2"	Stainless Steel (300 Series)

DIRECT MOUNT TYPES (Flangless Case)



Style "C" is standard on 3 1/2" and 6" dial size direct mount thermometers and is extra cost option for 4 1/2" dial size.

Glass retaining ring is Bayonet type on style "C" and slip-on type on style "I".

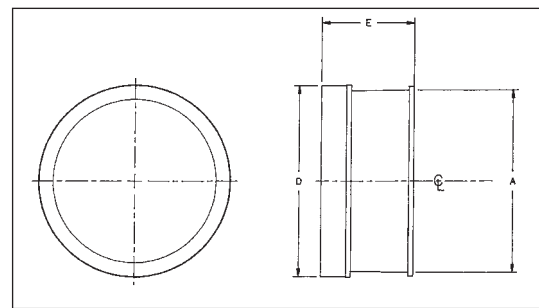

GAUGE SIZE		A	BEZEL-D		E
			BAY'NT	SLIP	
3 1/2	INCH	3 3/8	4 1/8	-	2
	MM	98	105	-	51
4 1/2	INCH	4 15/16	5	-	2 5/8
	MM	125	127	-	60
6	INCH	6 7/16	6 1/2	-	2 7/16
	MM	164	165	-	62

STYLE	DIAL SIZE(S)	MATERIAL
C	3 1/2" - 4 1/2" - 6"	Aluminum Black Textured Enamel Finish



BAYONET TYPE GLASS RETAINING RING
Standard on all stainless steel adjust angle, extra cost on all other 3 1/2" or 4 1/2" dial size direct mount thermometers.

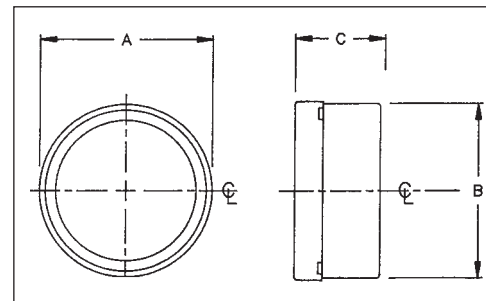

GAUGE SIZE		A	B	C
4 1/2	INCH	4 7/8	4 1/16	2 3/16
	MM	124	116	56

STYLE	DIAL SIZE(S)	MATERIAL
Y	4 1/2"	Stainless Steel (300 Series)

NOTE: ALL DIMENSIONS ARE APPROXIMATE.

FLUSH PANEL MOUNT TYPES



Flanged threaded glass retaining ring for full flush mounting.

Extra cost option on all dial size remote mount thermometers.

NOTE: Rear (back) connections are recommended for flush mounting. Bottom connection is also available.

NOTE: Style "E" formerly was style "AF".

STYLE	DIAL SIZE(S)	MATERIAL
E	3½", 4½", 6" and 8½"	Aluminum Black Textured Enamel Finish

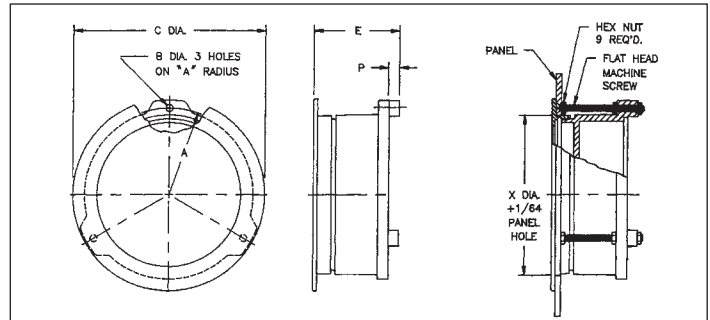

GAUGE SIZE	A	B	C	D	E	P	X	SCREW SIZE
3½	INCH	2 ³ / ₁₆	7 ¹ / ₃₂	5	4 ¹⁵ / ₁₆	2	4	10-32 x 2½
	MM	56	6	127	125	51	102	
4½	INCH	2 ¹¹ / ₁₆	7 ¹ / ₃₂	5 ⁷ / ₈	6	2 ⁷ / ₁₆	5	10-32 x 2½
	MM	68	6	149	152	62	127	
6	INCH	3½	9 ¹ / ₃₂	7 ⁵ / ₈	7 ³ / ₄	2 ¹ / ₁₆	6½	¼-20 x 2½
	MM	89	7	194	197	62	165	
8½	INCH	4 ¹³ / ₁₆	9 ¹ / ₃₂	10 ¹ / ₈	10 ³ / ₈	2 ⁵ / ₁₆	9	¼-20 x 2½
	MM	122	7	257	264	59	229	

HINGED FRONT TYPE FOR FLUSH MOUNTING



Molded plastic hinged front ring allows easy access to dial and pointer.

Extra cost option on 4½" and 6" dial size remote mount thermometers.

NOTE: Only available with rear (back) connection.

STYLE	DIAL SIZE(S)	MATERIAL
W	4½" and 6"	Aluminum Black Textured Enamel Finish

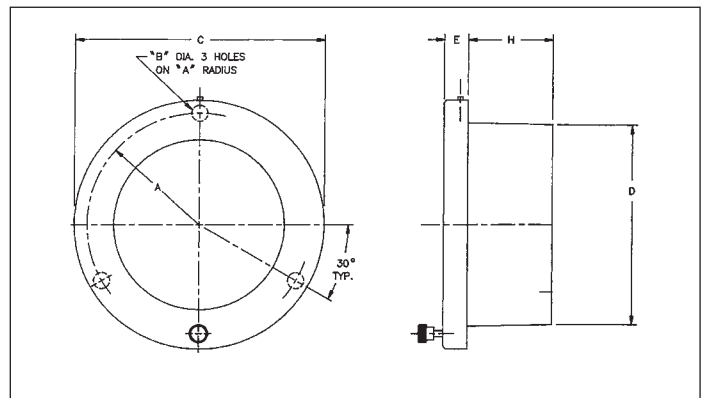

GAUGE SIZE	A	B	C	D	E	H	X
4½	INCH	2 ¹¹ / ₁₆	3 ¹ / ₁₆	6 ³ / ₁₆	4 ⁷ / ₈	5 ⁵ / ₈	4 ¹⁵ / ₁₆
	MM	68	5	157	124	16	125
6	INCH	3½	3 ¹ / ₁₆	7 ¹³ / ₁₆	6 ⁵ / ₈	1 ³ / ₄	6 ⁷ / ₁₆
	MM	89	5	198	168	44	164

X-PANEL HOLE CUT-OUT DIAMETER

FLUSH PANEL MOUNT TYPES

Front flanged case for semi-flush mounting.

Style "B" has Bayonet type glass retaining ring.

Style "H" has chrome like slip on glass retaining ring.

Extra cost option on all remote mount thermometers.

NOTE: Only available with rear (back) connection.

STYLE	DIAL SIZE(S)	MATERIAL
B	3½" - 4½" - 6"	Aluminum Black Textured Enamel Finish
H	8½" Only	

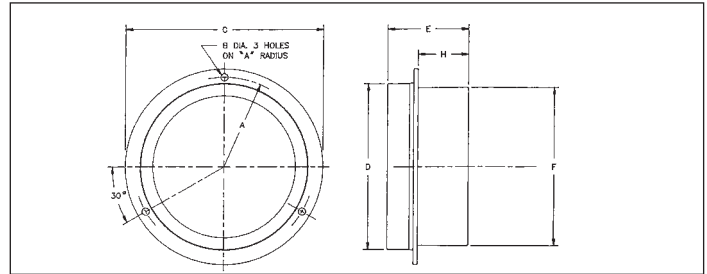

GAUGE SIZE		A	B	C	D	E	F	H	X
3½	INCH	2¼	¼	4 ¹⁵ / ₁₆	4 ¹ / ₈	2	3 ¹³ / ₁₆	1 ¹ / ₃₂	3 ¹⁵ / ₁₆
	MM	57	6	125	105	51	97	26	100
4½	INCH	2 ¹ / ₁₆	¼	5 ⁵ / ₈	5	2¼	4¾	1½	4 ⁷ / ₈
	MM	68	6	149	127	57	121	38	124
6	INCH	3½	¾	7 ⁹ / ₁₆	6½	2 ⁷ / ₁₆	6 ⁵ / ₁₆	1 ⁷ / ₁₆	6 ⁵ / ₁₆
	MM	89	7	192	165	62	157	37	160

X-PANEL HOLE CUT-OUT DIAMETER



Front flanged case for semi-flush mounting.

Bayonet type glass retaining ring.

Extra cost option 4½" dial size remote mount thermometers.

NOTE: Only available with rear (back) connection.

STYLE	DIAL SIZE(S)	MATERIAL
V	4½"	Stainless Steel (300 Series)

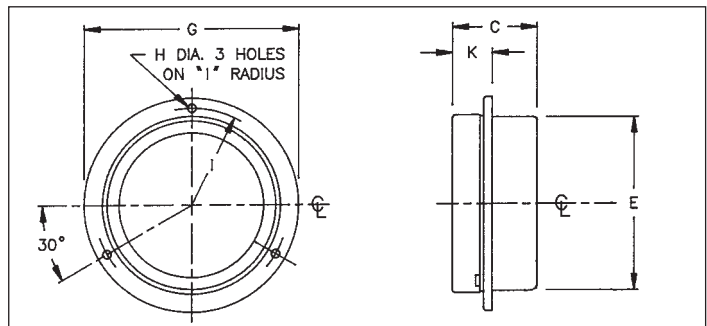

GAUGE SIZE		A	B	C	H	K	L
4½	INCH	2 ¹ / ₈	4 ⁹ / ₁₆	5 ¹⁵ / ₁₆	7 ⁷ / ₃₂	2 ¹ / ₁₆	1 ³ / ₁₆
	MM	54	116	151	6	68	21

NOTE: ALL DIMENSIONS ARE APPROXIMATE.

FEATURES	OPTION CODE
Plastic Lens	PD
Shatterproof Glass	SG
Movable Red Set Hand	SH
Dual Red Set Hands	ST
Markings on Dial	DM
Maximum Indicating Hand	EP
Minimum Indicating Hand	EQ
Paper Tag Attached to Instrument	NN
Stainless Steel Tag Attached by Wire	NH
Special Dials (Minimum Quantity Required)	SS

ELECTRIC CONTACTS – 4½" DIAL SIZE ONLY

The electric contact feature is a switching mechanism actuated by the indicating pointer. Switch points are adjustable and can be set throughout the 270° arc. Contacts are used to activate alarms and relays.

(Not recommended for continuous switching).



STANDARD FEATURES

- High impact polycarbonate enclosure for ambient temperature up to 150°F
- Full scale contact adjustment from front of enclosure
- Magnetically assisted, silver alloy contact
- Accuracy ±2% of scale arc (add to instrument accuracy)
- Rated for ¼ amp, 110 volt AC non-inductive load
- Available in type P, E, W, Y cases

MODEL	GSHA (Code E1)	GHLDA (Code E2)
DESCRIPTION	Single adjustable contact designed to "make" on the rise.	Double adjustable contact designed to "make" on the rise at the high setpoint and "make" on the drop at the low setpoint "off-in-between"
CONNECTION	2' lead wires exit side of case thru a conduit fitting.	2' lead wires exit thru fitting in lower portion of enclosure.
WIRING DIAGRAM		

CONNECTING TUBING

TUBING TYPES	ARMOR MATERIAL	CAPILLARY MATERIAL	TUBING TYPE NO.
	PVC Over 0.280" O.D. Zinc Plated Steel Interlocked Spiral	Stainless Steel (347)	Q
	0.1875" O.D. Stainless steel (316), Smooth Bendable	Stainless Steel (347)	G
	0.125" O.D. Stainless Steel Braid (321)	Stainless Steel (347)	O

NOTE: Optional tubing types not available on "Econo Gas" type.

“K” SERIES THERMOWELLS

(Fits 3/8" O.D. Bulb with 1/2" NPSM Swivel Nut)

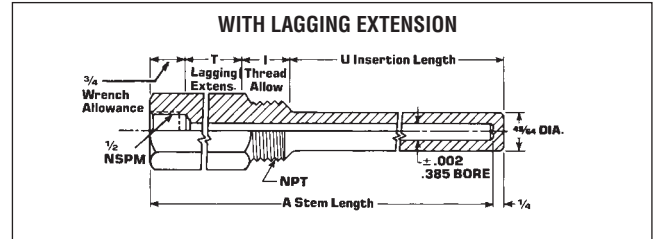
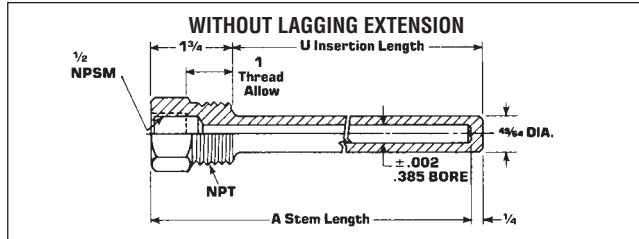

PART NUMBERS - 3/4 NPT					
A	U	BRASS	STEEL	304 SS	316 SS
4	2 1/2	S3B4K	S3S4K	S3G4K	S3J4K
6	4 1/2	S3B6K	S3S6K	S3G6K	S3J6K
9	7 1/2	S3B9K	S3S9K	S3G9K	S3J9K
12	10 1/2	S3B2K	S3S2K	S3G2K	S3J2K

PART NUMBERS - 3/4 NPT*						
A	U	T	BRASS	STEEL	304 SS	316 SS
6	2 1/2	2 1/2	L3B6K	L3S6K	L3G6K	L3J6K
9	4 1/2	3 1/2	L3B9K	L3S9K	L3G9K	L3J9K
12	7 1/2	3 1/2	L3B2K	L3S2K	L3G2K	L3J2K

*1 NPT AVAILABLE AT EXTRA COST, CHANGE 2ND DIGIT FROM 3 TO 4.

“5F” SERIES THERMOWELL

(Fits 5/8" O.D. Bulb with 1-20 NEF-2B Swivel Nut)

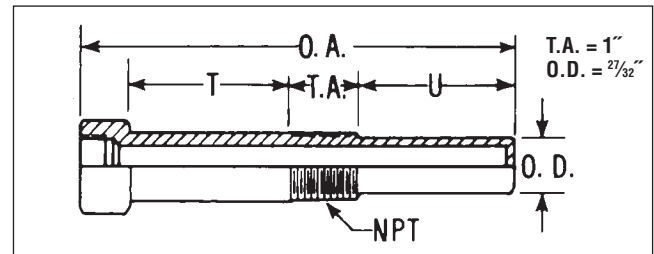
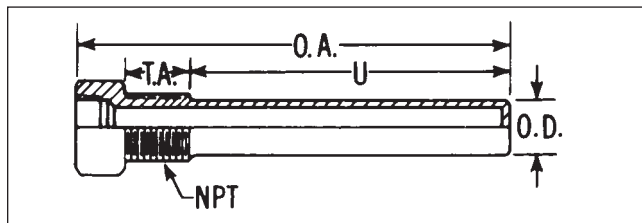

PART NUMBERS - 3/4 NPT**					
O.A. LENGTH	U DIM.	BRASS	STEEL	304 SS	316 SS
4 1/4	2 1/2	D1E5F2	D3E5F2	D6E5F2	D4E5F2
6 1/4	5	D1M5F2	D3M5F2	D6M5F2	D4M5F2
9 1/4	8	D1S5F2	D3S5F2	D6S5F2	D4S5F2
12 1/4	11	D1T5F2	D3T5F2	D6T5F2	D4T5F2

PART NUMBERS - 3/4 NPT**						
O.A. LENGTH	U DIM.	T DIM.	BRASS	STEEL	304 SS	316 SS
6 1/4	2 1/2	2 1/2	D1M5F2E	D3M5F2E	D6M5F2E	D4M5F2E
9 1/4	5 1/2	2 1/2	D1S5F2E	D3S5F2E	D6S5F2E	D4S5F2E
12 1/4	8 1/2	2 1/2	D1T5F2E	D3T5F2E	D6T5F2E	D4T5F2E

**1 NPT AVAILABLE AT EXTRA COST, CHANGE 6TH DIGIT FROM 2 TO 3.

“4B” SERIES THERMOWELLS - for econo thermometers

(Fits 1/2" O.D. Bulb with 3/4-24 NS-2 Swivel Nut)

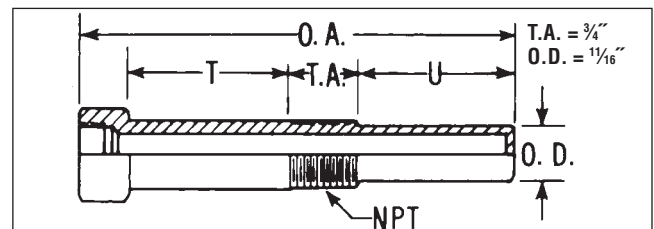
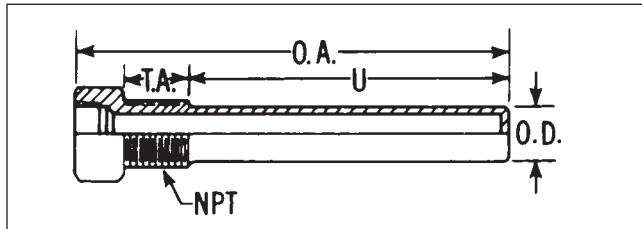

PART NUMBERS - 1/2 NPT***					
O.A. LENGTH	U DIM.	BRASS	STEEL	304 SS	316 SS
4	2 3/4	D1D4B1	D3D4B1	D6D4B1	D4D4B1
6 1/2	5 1/4	D1V4B1	D3V4B1	D6V4B1	D4V4B1
9 1/2	8 1/4	D1Z4B1	D3Z4B1	D6Z4B1	D4Z4B1
12 1/2	11 1/4	D1T4B1	D3T4B1	D6T4B1	D4T4B1

PART NUMBERS - 1/2 NPT***						
O.A. LENGTH	U DIM.	T DIM.	BRASS	STEEL	304 SS	316 SS
6 1/2	2 3/4	2 1/2	D1V4B1E	D3V4B1E	D6V4B1E	D4V4B1E
9 1/2	5 1/4	2 1/2	D1Z4B1E	D3Z4B1E	D6Z4B1E	D4Z4B1E
12 1/2	8 1/4	2 1/2	D1T4B1E	D3T4B1E	D6T4B1E	D4T4B1E

***3/4 NPT AVAILABLE AT EXTRA COST, CHANGE 6TH DIGIT FROM 1 TO 2.

FLANGES (2" O.D.) For use in air ducts, dryers, ovens, etc.

1/2 NPT FLANGE

Satin finish chrome plated brass.
For use with bulb style "3" only.

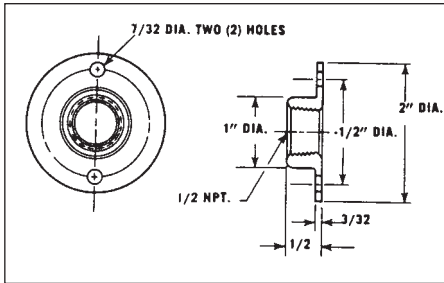

PART NUMBER 2F2

SET SCREW FLANGE

Brass.
For use on plain bulb.
(Style "C" only).

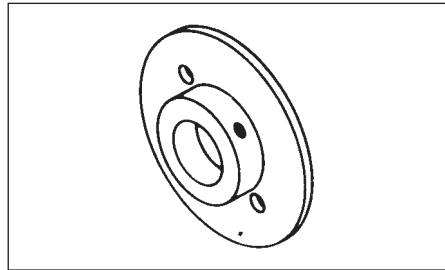

PART NUMBER A12-2

3/4"-24 NS-2 FLANGES

Brass.
For use with Econo-gas.
Bulb styles J, K and N only.

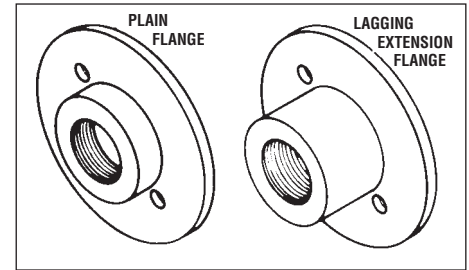

PART NUMBER A11-2 PART NUMBER A13-2

THREADED BUSHINGS

SERIES	INTERNAL THREAD	MALE THREAD	TYPE	BRASS	PART NUMBER	
					304 SS	316 SS
"4B"	3/4"-24 NS-2	1/2 NPT	Standard	D124B1	D624B1	D424B1
			Lagging	D124B1E	D624B1E	D424B1E
"5F"	1"-20 NEF-2B	3/4 NPT	Standard	D145F2	D645F2	D445F2
			Lagging	D145F2E	D645F2E	D445F2E

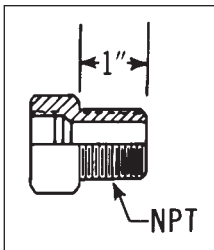

STANDARD BUSHING

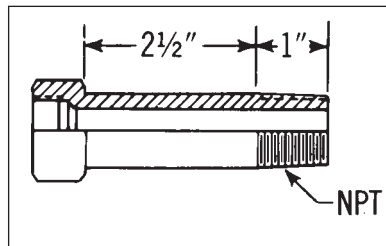

LAGGING EXTENSION BUSHING

1/2 NPT COMPRESSION UNION

For use on 1/2" O.D. rigid extension plain bulbs.
(Bulb Style "C").

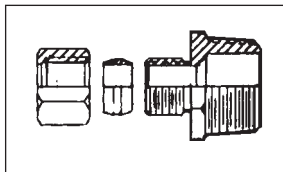

PART NUMBER	THREAD	MATERIAL
1A	1/2 NPT	Brass
1A-SS	1/2 NPT	304 SS

MOUNTING BRACKET

Used to support Type "A" air temperature bulb; 5" wall clearance provides good air circulation and minimum radiation effect. Nickel plated brass standard. For bulb style "A" only.

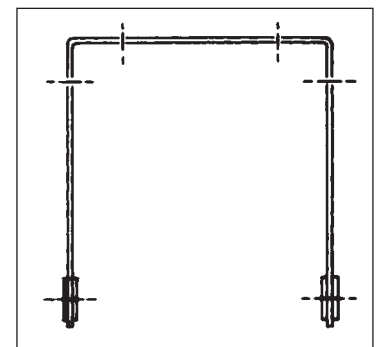

PART NUMBER A16



Temperature Conversion Table

NOTE: The numbers in the center of each column refer to the temperature either in degrees Celsius or Fahrenheit which it is desired to convert into the

other scale. If converting from Fahrenheit degrees to Celsius degrees the equivalent temperature will be found in the left column, while if converting from

degrees Celsius to degrees Fahrenheit the answer will be found in the column on the right.

-459.4 to -10			-9 to +50			51 to 110			120 to 700			710 to 1300		
C		F	C	F		C	F		C	F		C	F	
-273	-459.4		-22.8	-9	15.8	10.6	51	123.8	48.9	120	248	377	710	1310
-268	-450		-22.2	-8	17.6	11.1	52	125.6	54.4	130	266	382	720	1328
-262	-440		-21.7	-7	19.4	11.7	53	127.4	60.0	140	284	388	730	1346
-257	-430		-21.1	-6	21.2	12.2	54	129.2	65.6	150	302	393	740	1364
-251	-420		-20.6	-5	23.0	12.8	55	131.0	71.1	160	320	399	750	1382
-246	-410		-20.0	-4	24.8	13.3	56	132.8	76.7	170	338	404	760	1400
-240	-400		-19.4	-3	26.6	13.9	57	134.6	82.2	180	356	410	770	1418
-234	-390		-18.9	-2	28.4	14.4	58	136.4	87.8	190	374	416	780	1436
-229	-380		-18.3	-1	30.2	15.0	59	138.2	93.3	200	392	421	790	1454
-223	-370		-17.8	0	32.0	15.6	60	140.0	98.9	210	410	427	800	1472
-218	-360		-17.2	1	33.8	16.1	61	141.8	100	212	413.6	432	810	1490
-212	-350		-16.7	2	35.6	16.7	62	143.6	104	220	428	438	820	1508
-207	-340		-16.1	3	37.4	17.2	63	145.4	110	230	446	443	830	1526
-201	-330		-15.6	4	39.2	17.8	64	147.2	116	240	464	449	840	1544
-196	-320		-15.0	5	41.0	18.3	65	149.0	121	250	482	454	850	1562
-190	-310		-14.4	6	42.8	18.9	66	150.8	127	260	500	460	860	1580
-184	-300		-13.9	7	44.6	19.4	67	152.6	132	270	518	466	870	1598
-179	-290		-13.3	8	46.4	20.0	68	154.4	138	280	536	471	880	1616
-173	-280		-12.8	9	48.2	20.6	69	156.2	143	290	554	477	890	1634
-169	-273	-459.4	-12.2	10	50.0	21.1	70	158.0	149	300	572	482	900	1652
-168	-270	-454	-11.7	11	51.8	21.7	71	159.8	154	310	590	488	910	1670
-162	-260	-436	-11.1	12	53.6	22.2	72	161.6	160	320	608	493	920	1688
-157	-250	-418	-10.6	13	55.4	22.8	73	163.4	166	330	626	499	930	1706
-151	-240	-400	-10.0	14	57.2	23.3	74	165.2	171	340	644	504	940	1724
-146	-230	-382	-9.44	15	59.0	23.9	75	167.0	177	350	662	510	950	1742
-140	-220	-364	-8.89	16	60.8	24.4	76	168.8	182	360	680	516	960	1760
-134	-210	-346	-8.33	17	62.6	25.0	77	170.6	188	370	698	521	970	1778
-129	-200	-328	-7.78	18	64.4	25.6	78	172.4	193	380	716	527	980	1796
-123	-190	-310	-7.22	19	66.2	26.1	79	174.2	199	390	734	532	990	1814
-118	-180	-292	-6.67	20	68.0	26.7	80	176.0	204	400	752	538	1000	1832
-112	-170	-274	-6.11	21	69.8	27.2	81	177.8	210	410	770	543	1010	1850
-107	-160	-256	-5.56	22	71.6	27.8	82	179.6	216	420	788	549	1020	1868
-101	-150	-238	-5.00	23	73.4	28.3	83	181.4	221	430	806	554	1030	1886
-95.6	-140	-220	-4.44	24	75.2	28.9	84	183.2	227	440	824	560	1040	1904
-90.0	-130	-202	-3.89	25	77.0	29.4	85	185.0	232	450	842	566	1050	1922
-84.4	-120	-184	-3.33	26	78.8	30.0	86	186.8	238	460	860	571	1060	1940
-78.9	-110	-166	-2.78	27	80.6	30.6	87	188.6	243	470	878	577	1070	1958
-73.3	-100	-148	-2.22	28	82.4	31.1	88	190.4	249	480	896	582	1080	1976
-67.8	-90	-130	-1.67	29	84.2	31.7	89	192.2	254	490	914	588	1090	1994
-62.2	-80	-112	-1.11	30	86.0	32.2	90	194.0	260	500	932	593	1100	2012
-56.7	-70	-94.0	-0.56	31	87.8	32.8	91	195.8	266	510	950	599	1110	2030
-51.1	-60	-76.0	0	32	89.6	33.3	92	197.6	271	520	968	604	1120	2048
-45.6	-50	-58.0	0.56	33	91.4	33.9	93	199.4	277	530	986	610	1130	2066
-40.0	-40	-40.0	1.11	34	93.2	34.4	94	201.2	282	540	1004	616	1140	2084
-38.9	-38	-36.4	1.67	35	95.0	35.0	95	203.0	288	550	1022	621	1150	2102
-37.8	-36	-32.8	2.22	36	96.8	35.6	96	204.8	293	560	1040	627	1160	2120
-36.7	-34	-29.2	2.78	37	98.6	36.1	97	206.6	299	570	1058	632	1170	2138
-35.6	-32	-25.6	3.33	38	100.4	36.7	98	208.4	304	580	1076	638	1180	2156
-34.4	-30	-22.0	3.89	39	102.2	37.2	99	210.2	310	590	1094	643	1190	2174
-33.3	-28	-18.4	4.44	40	104.0	37.8	100	212.0	316	600	1112	649	1200	2192
-32.2	-26	-14.8	5.00	41	105.8	38.3	101	213.8	321	610	1130	654	1210	2210
-31.1	-24	-11.2	5.56	42	107.6	38.9	102	215.6	327	620	1148	660	1220	2228
-30.0	-22	-7.6	6.11	43	109.4	39.4	103	217.4	332	630	1166	666	1230	2246
-28.9	-20	-4.0	6.67	44	111.2	40.0	104	219.2	338	640	1184	671	1240	2264
-27.8	-18	-0.4	7.22	45	113.0	40.6	105	221.0	343	650	1202	677	1250	2282
-26.7	-16	3.2	7.78	46	114.8	41.1	106	222.8	349	660	1220	682	1260	2300
-25.6	-14	6.8	8.33	47	116.6	41.7	107	224.6	354	670	1238	688	1270	2318
-24.4	-12	10.4	8.89	48	118.4	42.2	108	226.4	360	680	1256	693	1280	2336
-23.3	-10	14.0	9.44	49	120.2	42.8	109	228.2	366	690	1274	699	1290	2354
			10.0	50	122.0	43.3	110	230.0	371	700	1292	704	1300	2372

INTERPOLATION FACTORS

C	F	C	F
0.56	1	3.89	7
1.11	2	4.44	8
1.67	3	5.00	9
2.22	4	5.56	10
2.78	5		
3.33	6		



Weksler Instruments
250 E. Main Street, Stratford, CT 06614
Tel: 203-378-8281 • Fax: 203-385-0408
www.ashcroft.com