



INSTALLATION, OPERATION & MAINTENANCE INSTRUCTIONS

1455 Kleppe Lane ♦ Sparks, NV 89431-6467 ♦ (775) 359-4712 ♦ Fax (775) 359-7424
E-mail: haws@hawsco.com ♦ website: www.hawsco.com

No. 2081781 (18)

Model 8317CTFP (120V) & 8317CTFP.220V

NOTE TO INSTALLER: Please leave this information with the Maintenance Department.

LIMITED WARRANTY

HAWS warrants that this specific product is guaranteed against defective material or poor workmanship for a period of **one year from date of shipment**. HAWS liability under this warranty shall be discharged by furnishing without charge F.O.B. HAWS Factory any goods, or part thereof, which shall appear to the Company upon inspection to be of defective material or not of first class workmanship, provided that claim is made in writing to Haws within a reasonable period after receipt of the product. Where claims for defects are made, the defective part or parts shall be delivered to the Company, prepaid, for inspection. HAWS will not be liable for the cost of repairs, alterations or replacements, or for any expense connected therewith made by the owner or his agents, except upon written authority from HAWS, Sparks, Nevada. HAWS will not be liable for any damages caused by defective materials or poor workmanship, except for replacements, as provided above. Buyer agrees that Haws has made no other warranties either expressed or implied in addition to those above stated, except that of title with respect to any of the products or equipment sold hereunder and that HAWS shall not be liable for general, special, or consequential damages claimed to arise under the contract of sale.

The emergency equipment manufactured by HAWS is warranted to function if installation and maintenance instructions provided are adhered to. The units also must be used for the purpose for which they were intended. This product is intended to supplement first-aid treatment. Due to widely varying conditions, Haws cannot guarantee that the use of this emergency equipment will prevent serious injury or the aggravation of existing or prior injuries.

NO OTHER WARRANTIES EXPRESSED OR IMPLIED ARE AUTHORIZED, PROVIDED OR GIVEN BY HAWS.

SHOULD YOU EXPERIENCE DIFFICULTY WITH THE INSTALLATION OF THIS MODEL PLEASE CALL:

TECHNICAL SUPPORT: 1-800-766-5612

FOR CUSTOMER SERVICE: 1-888-640-4297

RECOMMENDED TOOLS: Pipe joint sealant, screwdriver, pipe wrench, three (3) rust resistant anchors (3/8" diameter), silicone caulking, level.

LOCATION OF UNIT: The Model 8317CTFP (120V) & 8317CTFP.220V Emergency Shower Eye / Face Wash should be installed in close proximity to potential accident areas. It should be clearly identified, free from obstructions and easy to access. Suitable for use in Class 1, Division 2 Group B,C,& D areas. Temperature rating T6 (85° C).

ELECTRICAL SUPPLY FOR MODEL 8317CTFP: Electrical power required for standard heat traced unit is **120 VAC**. Average power consumption at 50° F (10° C) ambient temperature is 125 watts. Maximum less lighting is 150 watts. Connection at input junction box is 3/4" NPT. **DURING POTENTIALLY FREEZING PERIODS; INSURE THAT UNIT IS CONNECTED TO A CONTINUOUS POWER SUPPLY.**

ELECTRICAL SUPPLY FOR MODEL 8317CTFP.220V: Electrical power required for standard heat traced unit is **220 VAC**. Average power consumption at 50° F (10° C) ambient temperature is 125 watts. Maximum less lighting is 150 watts. Connection at input junction box is 3/4" NPT. **DURING POTENTIALLY FREEZING PERIODS; INSURE THAT UNIT IS CONNECTED TO A CONTINUOUS POWER SUPPLY.**

WATER SUPPLY: The minimum recommended line is 1-1/4" IPS with 30-90 psi (2-6 ATM) flowing pressure. An inlet filter is recommended where sediment or mineral content is a problem. Inlet connection is 1-1/4" IPS. **WATER SUPPLY MUST BE FREEZE PROTECTED.**

MAINTENANCE: In freezing conditions, wipe eye/face wash head and dust cover dry after each use to prevent unwanted ice buildup. SP158B Freeze Protection Valve is a field serviceable item Refer to SP158B Manual for more information.

WARNING: Fire and shock hazards: Must use a ground fault electrical protection device (30mA GFEPD) for Heat Trace. Electrical fault currents may be insufficient to trip a conventional circuit breaker.

INSTALLATION PROCEDURE

Refer to Installation Drawings for clarification. Use pipe joint sealant on all connections.

STEP 1: Prepare the emergency shower foundation locating three 3/8" anchors (not supplied), for shower floor flange. Note flange hole positions so shower head eye/face wash and supply inlet will be in proper direction. Raise shower into position and shim under floor flange if required to maintain upright vertical.

STEP 2: Connect water supply as follows: **This model is designed for either a top water supply or a bottom water supply.** This model is shipped with a complete 1-1/4" IPS union connected at the top supply inlet. At the bottom supply inlet there is only half of a 1-1/4" IPS union. The other half of the union is connected to a freeze protection bleed valve located inside the shipping carton. Remove outer half of the 1-1/4" union from the top water inlet. Assemble the half union onto 1-1/4" IPS male thread of either the top or bottom water supply.

Complete supply connection at the desired 1-1/4" union. Attach the other half union with the freeze valve attached to the other unused union and complete the connection. Refer to SP158B Freeze Protection Valve installation instructions on Sheets 2 and 3 of installation drawing.

Turn on water supply and check for leaks, then operation of eye/face wash and shower together. If flow of either is inadequate check troubleshooting chart. Heat trace (supplied), insulate and weather seal inlet union and above ground supply (by others). If flow switch is used, heat-trace and insulate 6" above flow switch tee.

INSTALLATION PROCEDURE...

STEP 3: Connect electrical power supply conduit to input junction box using suitable conduit fitting into 3/4" NPT inlet. Install optional area light and indicator light, if desired. **For MODEL 8317CTFP (120V):** connect **120 volt AC** line to 16 gauge shower wires as follows: Black = 120 VAC, White = Neutral, Green = Ground. **For MODEL 8317CTFP.220V:** Connect **220 volt AC** line to 16 gauge shower wires as follows: Black = 220 VAC, Red = 2nd Hot, Green = Ground. Turn on power supply to complete installation. (See Electrical Schematic Drawing, Sheet 4 of Installation Drawing).

OPERATING INSTRUCTIONS

Power to the 8317CTFP (120V) & 8317CTFP.220V may be left on year round. The non-adjustable thermostat will shut off heat cable when air temperature rises to 55° - 65° F (12° - 18° C). Heat cycle will repeat when air temperature drops to between 45° -55° F (7° - 13°C). Periodic check of water temperature from shower or eye/face wash will confirm normal operating temperatures between 45°- 95°F (7°-35°C).

This unit is heated by low power heat trace cable suitable for freeze protection but not suitable for providing a warm shower from a cold water supply. Moments after activating shower, water temperature will drop to supply temperature.

ANSI recommends a comfortable shower temperature range of 60°F (15°C) to 100°F (38°C). For the protection of the user, we strongly recommend that some system be installed to provide tempered (warm) water to this shower and eye/face wash. Heat trace cable used on this shower heats slowly and may take 90 minutes to complete a full heat cycle.

No drain connection at bleed valve(s) is normally required. Valve(s) will remain closed unless power outage, high ambient temperature (with optional scald protection valve, only) or malfunction occurs (see Troubleshooting).

NOTE: IF GROUND WATER IS BELOW 38°F (3.3°C) SIMPLY TESTING SHOWER MIGHT CAUSE BLEED VALVE TO OPEN. ONCE OPENED, COLD GROUND WATER WILL KEEP BLEED VALVE OPEN. SEE TROUBLESHOOTING GUIDE FOR PROCEDURE TO CLOSE BLEED VALVE ONCE OPENED.

Periodic tests for proper function of shower and eye/face wash should be performed and recorded on inspection tags attached to unit or in separate maintenance logbook (preferred).

IMPORTANT SAFETY NOTICE

THE NATIONAL ELECTRICAL CODE REQUIRES GROUND-FAULT EQUIPMENT PROTECTION ON EACH HEATING CABLE BRANCH CIRCUIT. TO REDUCE THE RISK OF FIRE CAUSED BY DAMAGE OR IMPROPER INSTALLATION, CIRCUIT BREAKERS SUCH AS SQUARE D QO-EPD AND QOB-EPD OR EQUIVALENT, WITH A 30mA TRIP LEVEL, SHOULD BE USED. PLEASE SUBSTITUTE THESE BREAKERS WHEREVER REFERENCE IS MADE TO CONVENTIONAL BREAKERS IN THIS DOCUMENT. ALTERNATIVE DESIGNS PROVIDING COMPARABLE LEVELS OF GROUND-FAULT PROTECTION MAY ALSO BE ACCEPTABLE.

TROUBLESHOOTING

| PROBLEM | REPAIR CHECKLIST |
|---|--|
| 1. Continuous flow from freeze bleed valve. | 1. If bleed water temperature is above 45°F (7°C), service bleed valve. For specific instruction regarding removal, maintenance and re-installment of this model, contact Haws Technical Support at 1-800-640-5612. If below 45°F (7°C), verify electric power to unit, then check thermostat. See item 3 below. Once opened, cold supply water, (45°F (7°C)), will keep freeze bleed valve open. To shut bleed valve, it must be warmed above 45°F (7°C). |
| 2. Continuous flow from scald bleed valve. (Optional valve). | 2. If bleed water temperature is below 90°F (32°C), service bleed valve. For specific instruction regarding removal, maintenance and re-installment of this model, contact Haws Technical Support at 1-800-640-5612. Above 100°F (38°C) may be due to direct sunlight or excess ambient temperature. |
| 3. Shower and eye/face wash water temperature below 40°F or above 100°F. | 3. Shut off electric power. All electric connections are made inside external junction box. Thermostat is mounted in top port of junction box. Disconnect thermostat leads from terminal block and wire nut in junction box. Check thermostat continuity: open circuit above 65°F (18°C), closed below 45°F (7°C). Thermostat is not adjustable and should be replaced if either of the continuity checks are incorrect. If unit is subject to freezing temperatures, temporarily disconnect thermostat and reconnect wiring to bypass thermostat and protect shower from freezing until replacement thermostat can be installed. Self-regulating heat trace cable will not overheat shower until air temperature rises above 85°F (30°C). |
| 4. Insufficient flow at shower and eye/face wash. | 4. Verify minimum 30 PSI (2 ATM), 28 gallon (106 liters per minute) available supply. Check for blockage in lines. |
| 5. Insufficient flow at eye/face wash only. | 5. Probable clogging of flow control due to inadequate line flushing. Turn water supply off. Unscrew eye/face wash heads and adapter to gain access and clean flow control. |
| 6. Insufficient water flow at the showerhead, however, eye/face wash is sufficient. | 6. Probable clogging of flow control inside showerhead. Unscrew showerhead off of elbow and clean rubber flow control. |
| 7. Shower and eye/face wash valve stem leak. | 7. Remove shower arm or eye/face wash push flag. Peel black trim strip from shower and separate housing halves. Peel back or remove insulation to gain access to valve. Remove "U" bracket from valve stem and tighten valve stem hex packing nut to stop leak. Reassemble bracket, insulation, shower housing and valve arm. |
| 8. Shower and eye/face wash valve leaks. (Does not shut off completely). | 8. Disconnect power to unit. Disassemble as in item 6. Check valve arm stop tang for damage. Repair or replace valve assembly. Heat cable is looped around valve and should be pulled away from valve. Remove valve. Reverse above steps to reassemble. |

PARTS BREAKDOWN

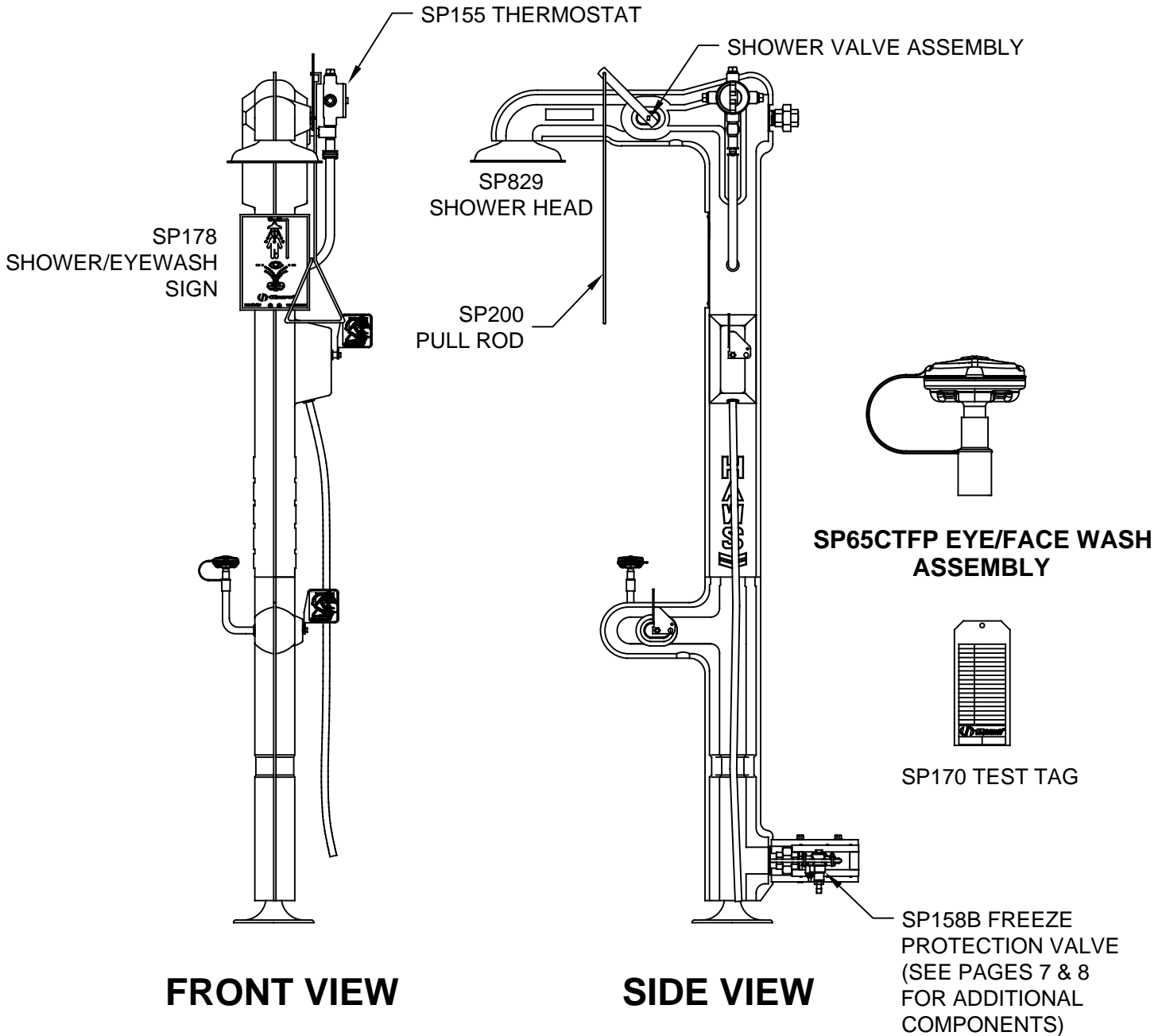

FRONT VIEW

SIDE VIEW

WHEN ORDERING PARTS PLEASE SPECIFY MODEL NUMBER.

| | | | | | |
|---|------------------|--------------------------|-------------------------------|---|--|
|  | | Haws [®] | | 1455 KLEPPE LANE SPARKS, NEVADA 89431 (775) 359-4712 FAX (775) 359-7424 E-MAIL: HAWS@HAWSCO.COM WEBSITE: WWW.HAWSCO.COM | |
| | | | | ECN NO. REVISED PER BY ECN: 5241 VWC | MODEL(S) 8317CTFP(120V) - 8317CTFP.220V |
| DRAWN RTM | DATE 3/29/05 | CHKD VWC | | | |
| APPROVED FV | DATE 11/23/17 | SCALE: NA | DRAWING TYPE: PARTS BREAKDOWN | SIZE: A | SHEET 1 OF 1 |

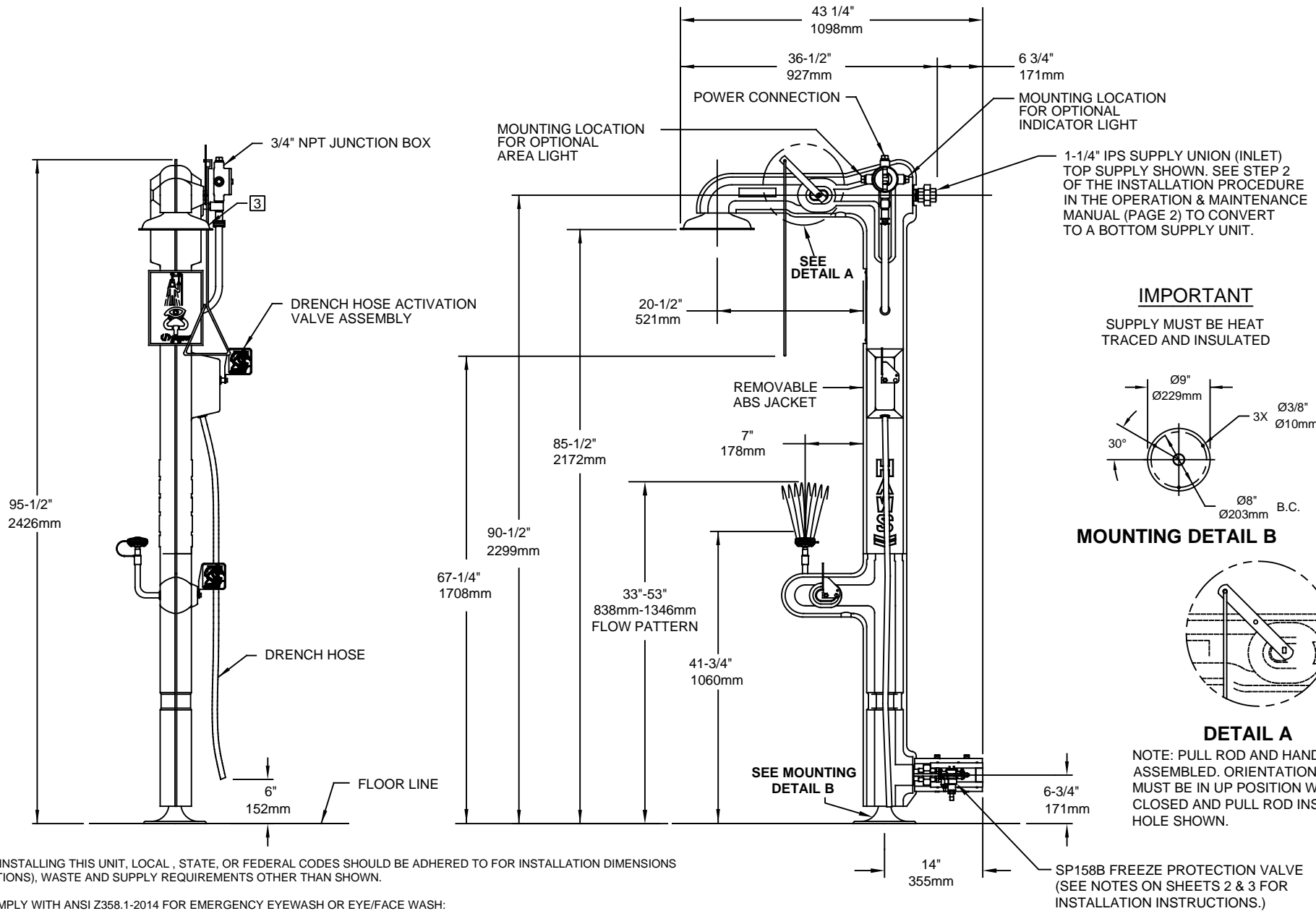

IMPORTANT
SUPPLY MUST BE HEAT TRACED AND INSULATED

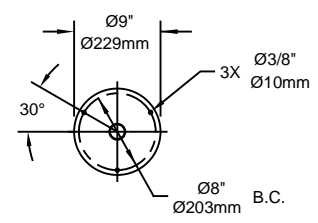

MOUNTING DETAIL B

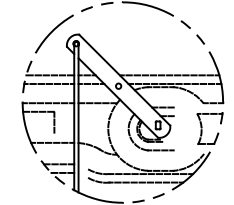

DETAIL A

NOTE: PULL ROD AND HANDLE NOT ASSEMBLED. ORIENTATION OF HANDLE MUST BE IN UP POSITION WHEN FULLY CLOSED AND PULL ROD INSERTED IN HOLE SHOWN.

- NOTES:
1. WHEN INSTALLING THIS UNIT, LOCAL, STATE, OR FEDERAL CODES SHOULD BE ADHERED TO FOR INSTALLATION DIMENSIONS (LOCATIONS), WASTE AND SUPPLY REQUIREMENTS OTHER THAN SHOWN.
 2. TO COMPLY WITH ANSI Z358.1-2014 FOR EMERGENCY EYEWASH OR EYE/FACE WASH: EYEWASH OR EYE/FACE WASH SHALL BE POSITIONED SUCH THAT FLUSHING FLUID PATTERN IS NOT LESS THAN 33" (838mm) AND NO GREATER THAN 53" (1346mm) FROM SURFACE ON WHICH USER STANDS; AND 6.0" (153mm) MINIMUM FROM WALL OR NEAREST OBSTRUCTION.
 3. DO NOT USE REGULAR PIPE SEALANT. IF NECESSARY USE DOW CORNING 832 SEALANT PLACING FIVE SMALL BEADS ON MALE THREADS, JUST ABOVE THE FIRST THREAD.
 4. DIMENSIONS MAY VARY BY ±1/2" (13 mm).

(NOTES CONTINUED ON SHEET 2.)

1455 KLEPPE LANE
SPARKS, NEVADA 89431
(775) 359-4712 FAX (775) 359-7424
E-MAIL: HAWS@HAWSCO.COM
WEBSITE: WWW.HAWSCO.COM

| | | | |
|--------------|-------------------------------|--|-----------------------------|
| ECN NO. 4632 | REVISED PER BY: ECN: 5241 VWC | MODEL(S) 8317CTFP(120V) / 8317CTFP.220V | PART NUMBER 0002081781.D |
| DRAWN: RTM | DATE: 3/29/05 | CHKD.: VWC | REVISION |
| APPROVED: FV | DATE: 11/23/17 | SCALE: NA | DRAWING TYPE: INSTALLATION |
| | | SIZE: A | SHEET 1 OF 4 |

NOTES: (CONTINUED FROM SHEET 1 OF 4)

4. FREEZE PROTECTION VALVE INSTALLATION INSTRUCTIONS:

- A** INSTALL VALVE SUB-ASSEMBLY INTO FEMALE SECTION OF UNION AND TIGHTEN WATER-TIGHT.
- B** FORM HEAT TRACE CABLE AROUND VALVE AND PLUG, APPLY 2X CABLE-TIES TO HEAT TRACE CABLE, AS SHOWN, ENSURING THAT HEAT TRACE CABLE IS PRESSED FIRMLY AGAINST SIDES OF VALVE (PUSH ANY LOOSE HEAT TRACE CABLE BACK INSIDE JACKET THROUGH RUBBER GROMMET). TRIM EXCESS CABLE-TIE STRAPPING.
- C** SLIDE INNER TUBE W/ PLUGGED END OVER VALVE WITH ADHESIVE SEAM FACING BOTTOM AND NON-PLUGGED END OF TUBE BUTTED UP AGAINST UNION SURFACE. REMOVE 2X ADHESIVE TAPE FROM SEAM AND SQUEEZE ADHESIVE SEAMS TOGETHER AROUND VALVE. APPLY 2X CABLE-TIES TO TUBE, IN APPROXIMATE LOCATIONS SHOWN. TRIM EXCESS CABLE-TIE STRAPPING.

(NOTES CONTINUED ON SHEET 3 OF 4)

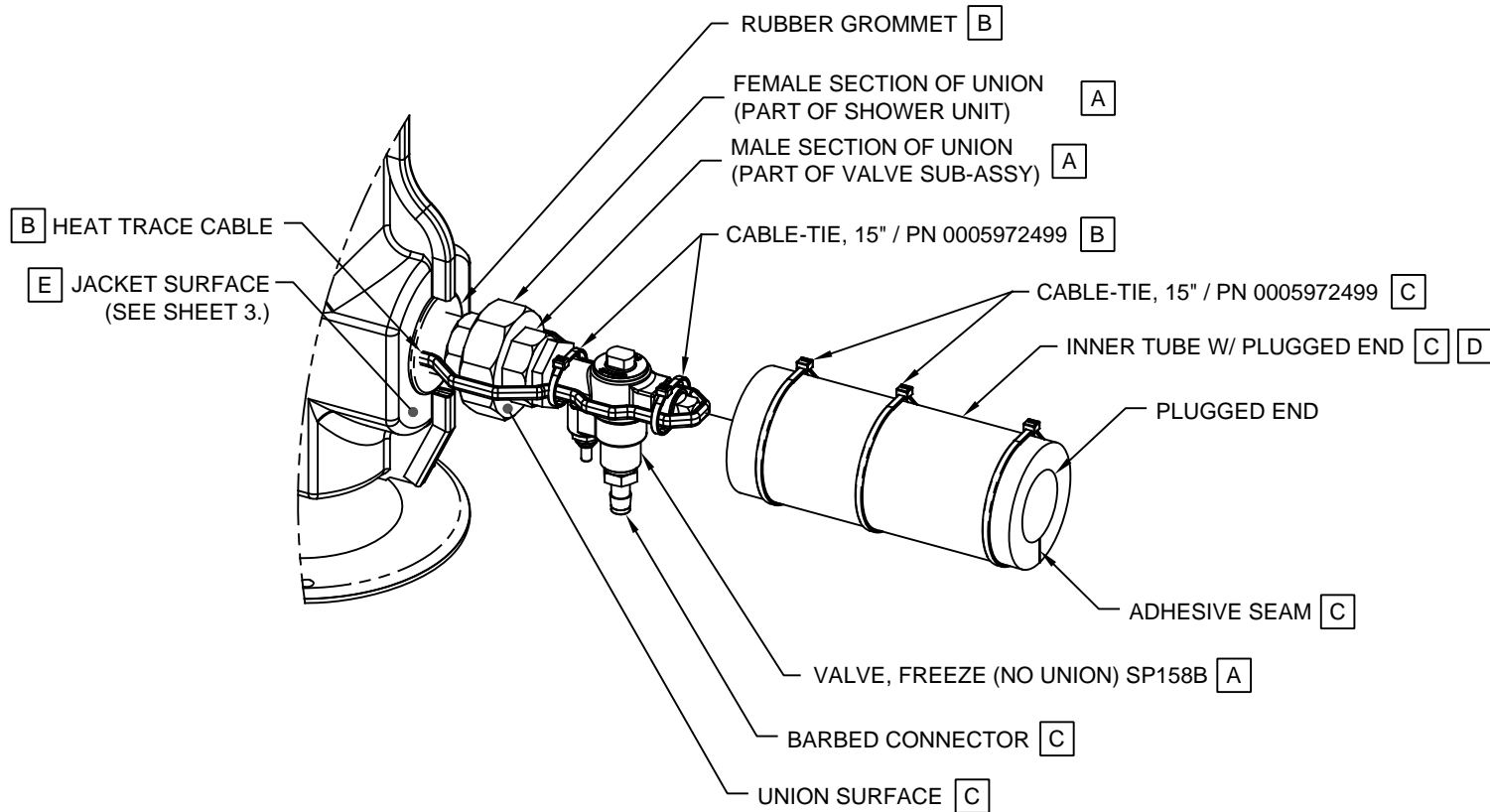

SP158B VALVE SHOWN CONNECTED TO BOTTOM UNION FOR REFERENCE ONLY. VALVE CAN BE INSTALLED AT TOP OR BOTTOM.

| | | | |
|---|--|---|--|
|  | | 1455 KLEPPE LANE SPARKS, NEVADA 89431 (775) 359-4712 FAX (775) 359-7424 E-MAIL: HAWS@HAWS.CO.COM WEBSITE: WWW.HAWS.CO.COM | |
| | | ECN NO. 4632 DRAWN: VWC APPROVED: FV | REVISED PER BY: ECN: 5241 VWC DATE: 12/2/12 DATE: 11/23/17 |
| SCALE: NA | | DRAWING TYPE: INSTALLATION | SIZE: A SHEET 2 OF 4 |

NOTES: (CONTINUED FROM SHEET 2 OF 4)

5. FREEZE PROTECTION VALVE INSTALLATION INSTRUCTIONS (CONTINUED):

D WRAP OUTER TUBE OVER INNER TUBE ENCAPSULATED VALVE WITH ADHESIVE SEAM ORIENTED PERPENDICULAR TO SEAM OF INNER TUBE. PUSH OUTER TUBE UP AGAINST JACKET SURFACE. WHEN TUBE IS MOUNTED FIRMLY AGAINST JACKET SURFACE, SQUEEZE TUBE AT BARBED CONNECTOR SUCH THAT BARBED NIPPLE PUSHES THROUGH OUTER TUBE WALL. (PUSHING CONNECTOR THROUGH WALL WILL EXTRUDE A CYLINDRICAL PLUG OF TUBING TO BREAK FREE. DISCARD PLUG.) PUSH TUBE DOWN EVEN FURTHER SO THAT HOLE IN TUBE STRETCHES AROUND HEXAGONAL BOSS OF CONNECTOR. SQUEEZE OUTER TUBE TIGHT UNTIL ADHESIVE SEAMS ARE CLOSE ENOUGH TO SEAL. REMOVE PROTECTIVE TAPE AND SEAL SEAMS.

E TO ENSURE PROPER INSULATION OF UNION; THERE MUST BE NO SPACE BETWEEN OUTER TUBE AND JACKET SURFACE (SEE SHEET 2 FOR SURFACE CALLOUT). THEREFORE, SLICE TWO PLACES, TOP SIDE AND BOTTOM SIDE, COMPLETELY THROUGH OUTER TUBE TO A LENGTH EQUAL TO DEPTH OF TRIM SEAL. FORCE SLICED TUBE AROUND TRIM SEAL AND PUSH TUBE TIGHTLY AGAINST JACKET, AS SHOWN. APPLY 2X CABLE-TIE HEAD, AND 2X CABLE-TIE STRAP, TO TUBE, IN APPROXIMATE LOCATIONS SHOWN. TRIM EXCESS STRAPPING.

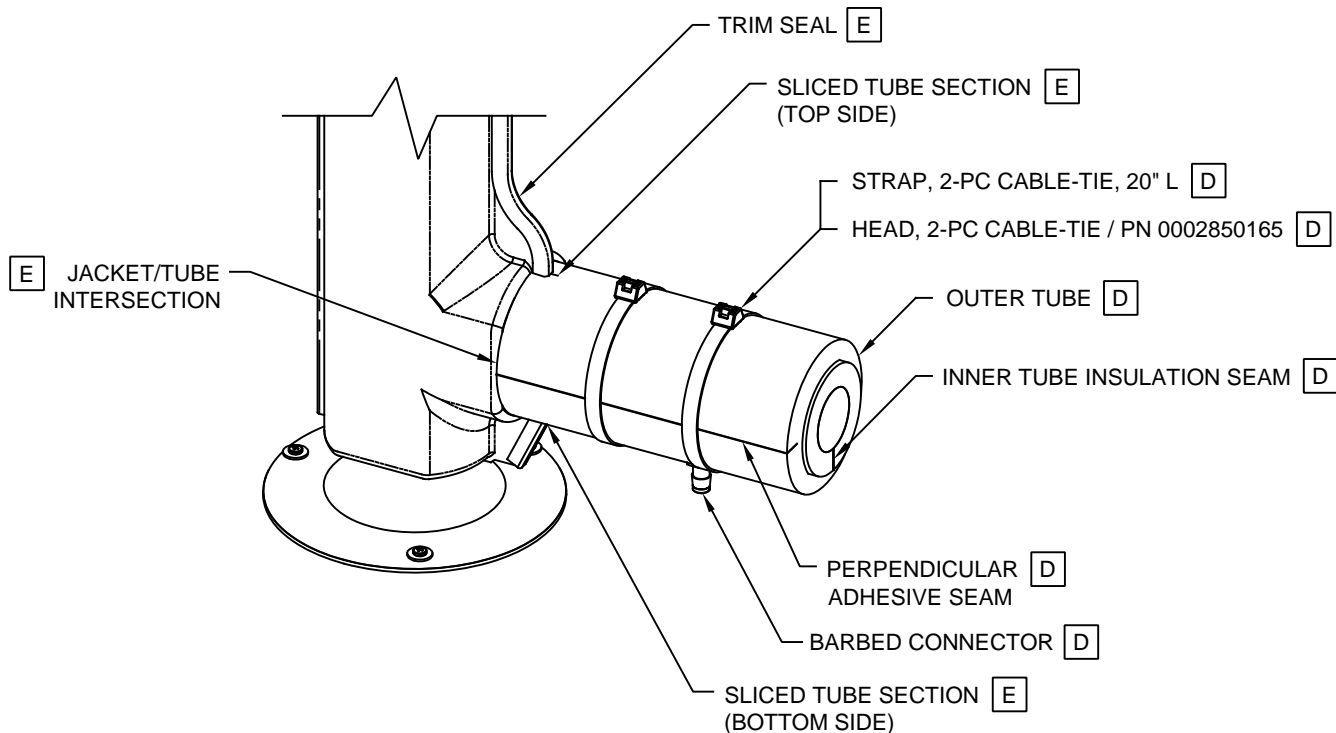

SP158B VALVE SHOWN CONNECTED TO BOTTOM UNION FOR REFERENCE ONLY. VALVE CAN BE INSTALLED AT TOP OR BOTTOM.

| | | | |
|---|--|---|---|
|  | | 1455 KLEPPE LANE SPARKS, NEVADA 89431 (775) 359-4712 FAX (775) 359-7424 E-MAIL: HAWS@HAWSO.COM WEBSITE: WWW.HAWSO.COM | |
| | | ECN NO. 4632 DRAWN: VWC APPROVED: FV | REVISED PER: ECN: 5241 DATE: 12/2/12 DATE: 11/23/17 |
| PART NUMBER 0002081781.D | | | REVISION 18 |
| SCALE: NA | | DRAWING TYPE: INSTALLATION | SIZE: A SHEET 3 OF 4 |

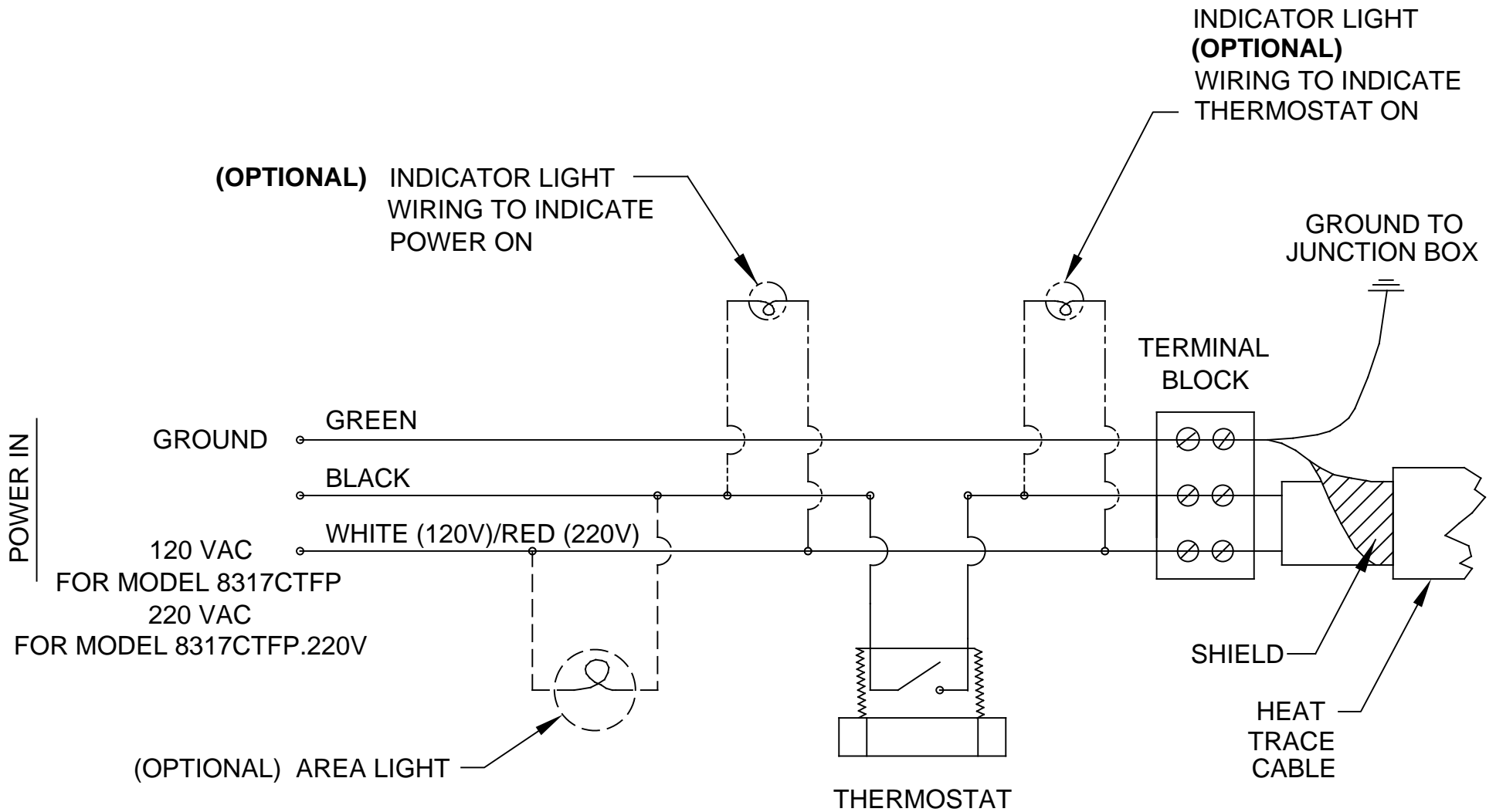

ELECTRICAL SCHEMATIC

(8317CTFP ONLY SUPPORTS TWO OPTIONS AT A TIME)

| | | | |
|---|--------------------------|---|--|
|  | | 1455 KLEPPE LANE SPARKS, NEVADA 89431 (775) 359-4712 FAX (775) 359-7424 E-MAIL: HAWS@HAWS.CO.COM WEBSITE: WWW.HAWS.CO.COM | |
| ECN NO. 4632 | REVISED PER ECN: 5241 | BY: VWG | MODEL(S) 8317CTFP(120V) / 8317CTFP.220V |
| DRAWN: RTM | DATE: 3/29/06 | CHKD.: VWG | PART NUMBER 0002081781.D |
| APPROVED: FV | DATE: 11/23/17 | SCALE: NA | REVISION 18 |
| DRAWING TYPE: INSTALLATION | | SIZE: A | SHEET 4 OF 4 |