

QUARTERHORSE 1/4 TURN NON FREEZE WALL HYDRANT WITH INTEGRAL VACUUM BREAKER

EXPOSED HOSE CONNECTION

FUNCTION: For installation in interior or exterior building walls where an exposed hose connection is acceptable. Provides positive non-freeze protection and features an integral vacuum breaker. Adaptable to all types of wall construction.

1/4 Turn of the Key Allows Full Flow to be Obtained

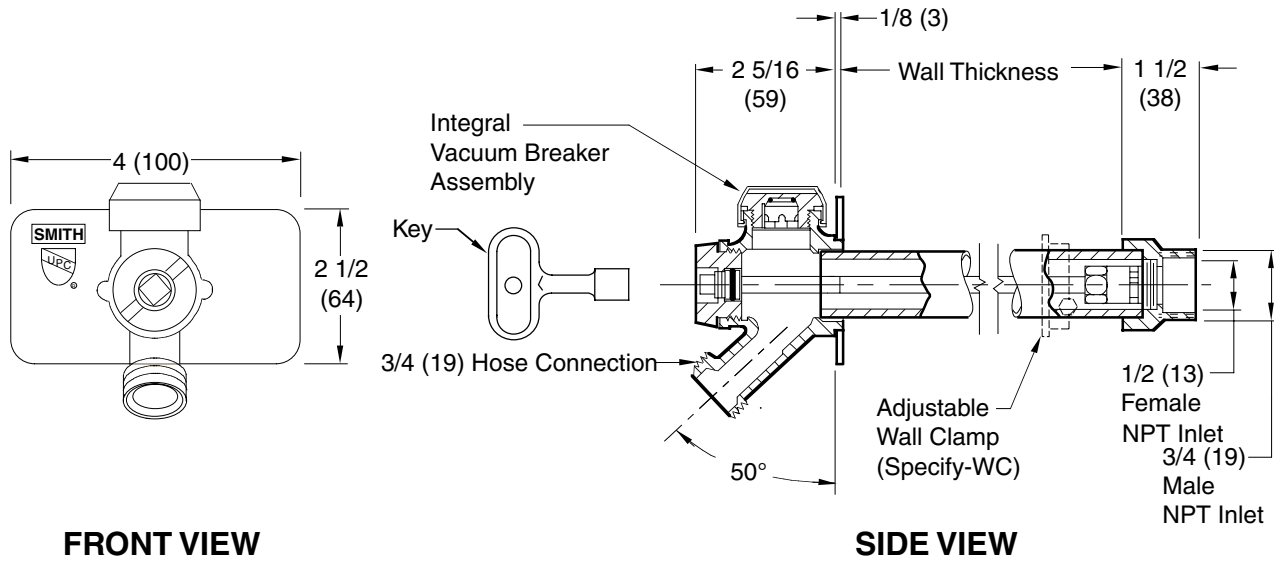

FIG. 5609QT

Seepage of a small amount of water may occur from the vacuum breaker upon the initial opening of this hydrant. This is normal operation.

REGULARLY FURNISHED:

Bronze Nickel Plated Quarter Turn Non-Freeze Hydrant with 3/4" (19) Hose Connection, Backer Plate, Integral Vacuum Breaker with Vandal Resistant Cap and "T" Handle Key.

VARIATIONS:

- Adjustable Wall Clamp -WC
- 1" (25) Hose Connection -HC1
- 1" (25) Male NPT Inlet Connection -IC1
- Wheel Handle -WH

OPTIONAL MATERIALS:

- Chrome Plated -CP
- Chrome Plated Backer Plate -BPCP
- Polished Bronze -PB
- Polished Bronze Backer Plate -BPPB

* Add 3/4" (19) to Overall Length When Specified

PATENTED

- NOTES:**
- Recommended wall opening 2(51) x 2(51). Hydrant shall be in the vertical position only, the hose connection must be on the bottom.
 - When ordering, specify wall thickness in 02"(51) increment as follows: 04(100), 06(150), 08(205), 10(255), 12(305), 14(355), 16(405), 18(455), 20(510), 22(560) or 24"(610). When wall clamp -WC is desired, increase wall thickness dimension by 2"(51).
 - All Jay R. Smith hydrants are manufactured with "NO-LEAD" brazing rings and USDA approved lubricants.
 - The AB1953, California Lead Law, and NSF/ANSI Standard 61-2008 - Drinking Water System Components are not applicable to Jay R. Smith hydrants as they do not convey/dispense water for human consumption through drinking or cooking.
 - Dimensions shown in parentheses are in millimeters.

5609QT

DIMENSIONS ARE SUBJECT TO MANUFACTURERS TOLERANCE AND CHANGE WITHOUT NOTICE

DRAWING NUMBER
S5609QT

SIZE
A

SCALE:
NONE

DATE:
1-2-90

APPROVED BY:
SJM

CHECKED BY:
SB

DRAWN BY:
EMB

FIGURE NUMBER

R P N M	6-13-11 5-17-11 10-7-09 3-26-99	Revised Note Added Note Revised Notes Revised	TBW TBW RN CMD	CL CL CL BS	WEIGHT POUNDS	VOLUME CUBIC FEET	FIGURE NUMBER 5609QT
REV.	DATE	DESCRIPTION	BY	CKD. BY			

SEE REVERSE SIDE

HYDRANT PARTS LIST

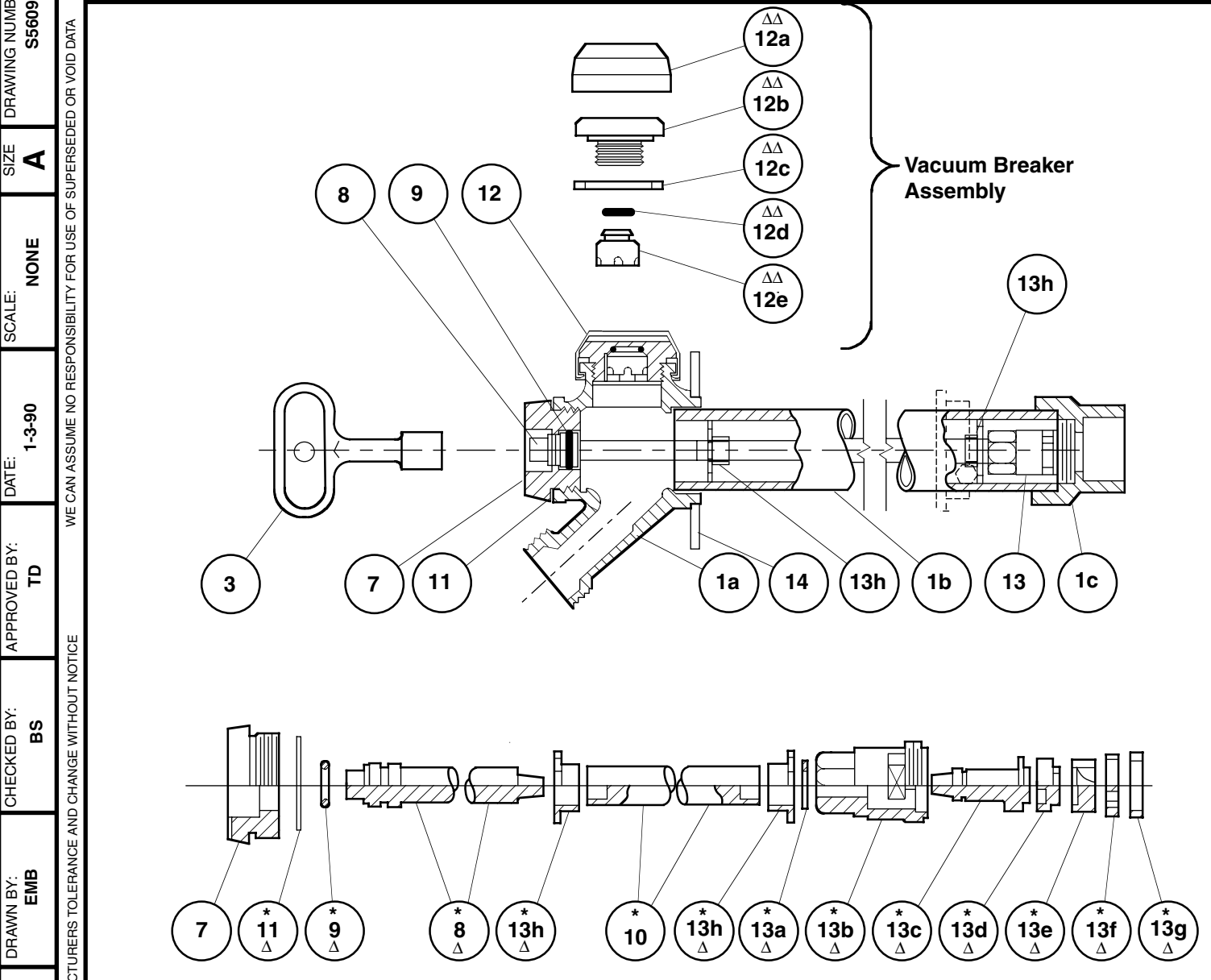

DRAWING NUMBER: 5609QTBS
 SIZE: A
 SCALE: NONE
 DATE: 1-3-90
 APPROVED BY: TD
 CHECKED BY: BS
 DRAWN BY: EMB

WE CAN ASSUME NO RESPONSIBILITY FOR USE OF SUPERSEDED OR VOID DATA
 DIMENSIONS ARE SUBJECT TO MANUFACTURERS TOLERANCE AND CHANGE WITHOUT NOTICE

Δ These Replacement Parts Available in HPRK-7
 ΔΔ These Replacement Parts Available in HPRK-7VB
 * These Parts Accessible from Face of Hydrant by Removing Face Nut.

HYDRANT PARTS LIST					
NO.	DESCRIPTION	NO.	DESCRIPTION	NO.	DESCRIPTION
1	Head/Casing Assembly	10	Operator Rod	13a	Retaining Ring
1a	Head	11	Face Nut Washer	13b	Valve Body
1b	Casing	12	Vacuum Breaker Assembly	13c	Valve Actuator
1c	Valve Housing	12a	VB Cap	13d	Nylon Thrust Washer
3	Key	12b	VB Body	13e	Rotating Ceramic Disc
7	Face Nut	12c	VB Washer	13f	Fixed Ceramic Disc
8	Actuator Shaft	12d	VB "O" Ring	13g	Silicon Rubber Seal
9	Actuator "O" Ring	12e	VB Piston	13h	Retainer Guide (2)
		13	Valve Body Assembly	14	Backer Plate w/Screws

FIGURE NUMBER	REV.	DATE	DESCRIPTION	BY	CKD. BY	WEIGHT POUNDS	VOLUME CUBIC FEET	FIGURE NUMBER
								5609QT