



# Instruction Sheet

## LTA-2 - Low Water Cutoff for Hot Water Boilers

102-350

SUPERSEDES: 5403576 - Rev C Dated October 6, 2008

EFFECTIVE: January 6, 2009

#5403576-REV D

PLANT ID 001-3915

### Listings/Approvals:

- UL GUIDE (MBPR) for Limit Controls per UL Standard 353 Limit Controls
- UL GUIDE (MBPR7) Controls, Limit Certified for Canada CSA Standard C22.2
- Fully meets installation requirements of CSD-1 for automatic controls



US Patents 6,904,800, 7,243,540  
and 7,317,993  
Other Patents Pending

### Maximum Probe Ratings:

Hot water only - 250 psi (17.6 kg/cm<sup>2</sup>) at 250°F (121°C)

**Probe Sensitivity:** 20K Ohms. Extended operation to 40K Ohms.

**Ambient Temperature:** 32°F to 150°F (0°C to 66°C)

**Enclosure Rating:** NEMA 1 for indoor use only

**Input Power:** 2.8 VA @ 120 VAC

2.8 VA @ 24 VAC supplied by a Class 2 power source

**Reset:** Automatic reset when water level returns to safe level

**Testing:** Integrated test switch for testing safety shutdown

Voltage	Contact Ratings*		Pilot Rating
	Motor Switch Rating		
	Full Load	Locked Rotor	
24 VAC	-	-	50 VA
120 VAC	7.5 A	43.2 A	125 VA
240 VAC	3.75 A	21.6 A	50 or 60 Hz

\* 1A resistive at 120°F to 150°F (49°C to 66°C)

### General:

The Low Water Cutoff (LTA-2) is a microprocessor based low water cutoff for detecting the presence of water in a boiler. The LTA-2 uses advanced signal processing to identify when the probe signal levels have decreased due to possible fouling. These advanced technologies permit extended operation for probe impedance up to 40K Ohms. The LTA-2 functions longer without requiring probe cleaning, and it functions normally under non-ideal installation conditions. The LTA-2 is designed for use with hot water boilers

and hot water heating boilers. (See each boiler manufacturers' specifications for recommended minimum safe water levels.)

During a low water condition, the "Status" LED will illuminate RED. Under normal conditions, it will illuminate GREEN. See "Status LED States" table for details.

## WARNING

- Installation must be performed by qualified personnel and in accordance with all national and local codes and ordinances.
- Read all instructions carefully and understand them before starting installation. Save instructions for future use.
- Instruct user how to test and operate this cutoff device as described in these instructions.
- Risk of explosion. Not for use in hazardous locations. Serious injury or death could result.
- The LWCO device must be installed in series ahead of other limit and operating controls installed on the boiler. When installations are complete, check for correct operation of ALL limit and operating controls.
- For use with hot water boilers and hot water heating boilers only. Use on steam boilers could cause improper operation resulting in property damage serious injury, and death.
- Shock Hazard. Disconnect power source before servicing. Serious injury or death could result.
- Hot or pressurized boiler systems can discharge steam and hot water. Cool boiler system to 80° F (27° C) and to 0 psi (0 bar) before servicing. Failure to do so could result in serious burns.

**LTA-2 Features:**

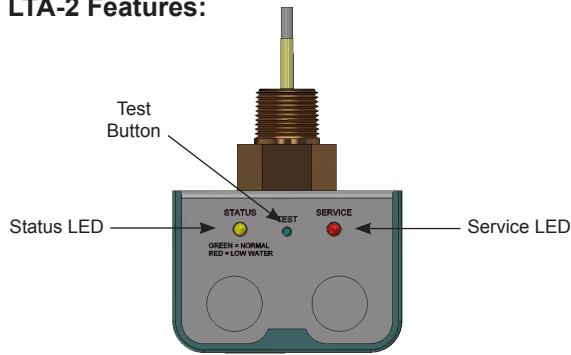

Item	Description
Status LED	Bi-color LED status indicator. See "LED States" table for details.
Service LED	Amber LED indicator that service is needed on LTA-2 or system.
Test Button	Push button switch for testing safety shutdown of boiler controls.

**LED States:**

Status LED	Service LED	Contacts	Meaning
Green	Off	Closed	Normal
Green	Amber	Closed	Safe water level, weak probe signal - Service soon.
Red	Off	Open	Low water condition, (LW)
Red	Amber	Open	Probe signal too weak, LW condition - Service <b>now</b> .
Blinking	Red	Open	Control failure. Lockout in LW condition.
Off	Off	Open	No power to LWCO.

**Installation:**

1. Install the probe above the minimum safe water level, as determined from the boiler manufacturer's literature. (See Fig. 1)  
**NOTE:** This may be in a tapping on the boiler or in the boiler supply or return piping.
2. Install the probe to extend into the boiler cavity or piping to make contact with the water.
3. Install the probe so that the exposed portion of the stainless steel is a minimum of 1/4" from any grounding surface inside the boiler (to prevent the probe from shorting). (See Fig. 2)
4. Tighten probe securely with a wrench, using bushing flats provided. Use pipe thread sealant to seal the probe threads.

**MINIMUM SAFE WATER LEVEL**  
**FIG. 1**

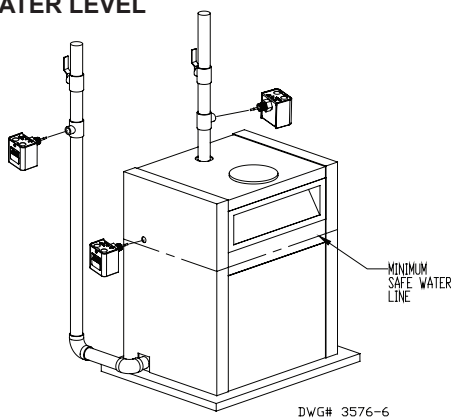

**PROBE SPACING REQUIREMENTS**  
**FIG. 2**

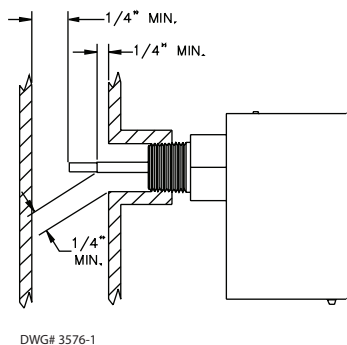

**⚠ CAUTION**

- Do not tighten by grasping the device enclosure. Use wrenching flats on the probe bushing only. Failure to install properly could damage the device and cause improper operation resulting in damage to equipment and property.
- Do not use manual reset low water cutoffs with automatic water feeders. Flooding, equipment damage, and property damage can result. Only use automatic water feeders with automatic reset low water cutoffs.
- Do not mount device with probe angled upward or deposits can accumulate on the probe.
- Mount only with probe facing horizontally or vertically downward and maintain 1/4" minimum clearance from electrode and pipe wall.
- Failure to install probe as directed can cause improper operation and damage to equipment and property.

**CONTROL UNIT MOUNTED ON PROBE**

**FIG. 3**

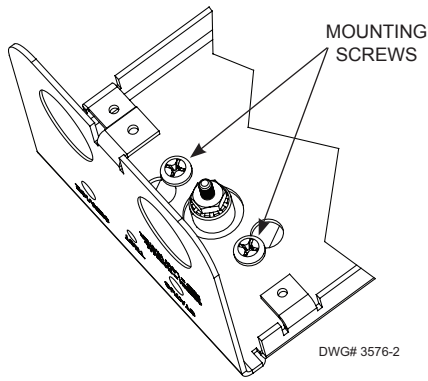

**LWCO**

**FIG. 4**

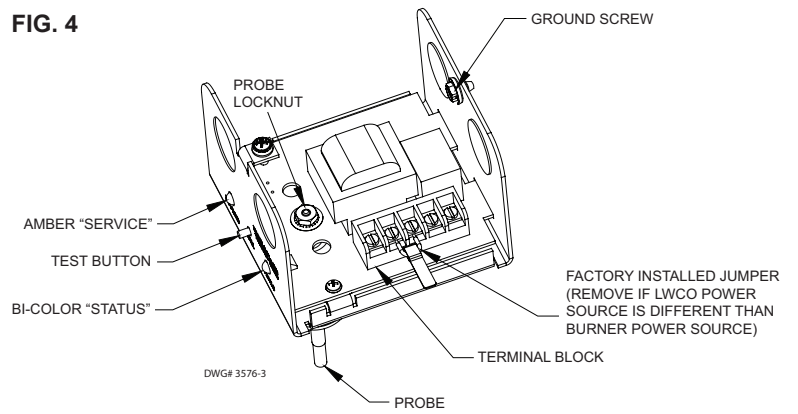

**INSTALLATION**

**IMPORTANT NOTES FOR PROBE INSTALLATION:**

**CAUTION**

Only use pipe thread sealant for sealing probe threads. Do not use Teflon tape. Use of Teflon tape can insulate probe electrically and can cause improper device operation and damage to equipment or property.

1. Be sure the probe is installed above the **minimum safe** water level, as previously determined from the boiler manufacturer's literature.
2. Be sure the probe extends into the boiler cavity or piping so that contact with the water is made. Do not install in locations where air can be trapped.
3. Be sure the exposed portion of the stainless steel probe is a *minimum* of 1/4" from any grounding surface inside the boiler to prevent the probe from shorting (see Fig 1).

**Control Unit Mounting onto Probe (See Fig. 3):**

1. Tighten the probe into the tapped location of the boiler with a wrench, using the bushing flats provided.
2. Make sure the heads of the two mounting screws in the probe bushing are loosened approximately 1/8" from the bushing surface.
3. Then remove the first lock washer/nut from the probe threads.
4. Orient the slotted holes in the control unit over the heads of the mounting screws of the probe and turn control unit counter-clockwise so that the ends of the slots are fully under the mounting screw heads. Tighten mounting screws.
5. Replace the probe locknut onto the electrode threads and tighten.

**LWCO OUTLINE DRAWING**

**FIG. 5**

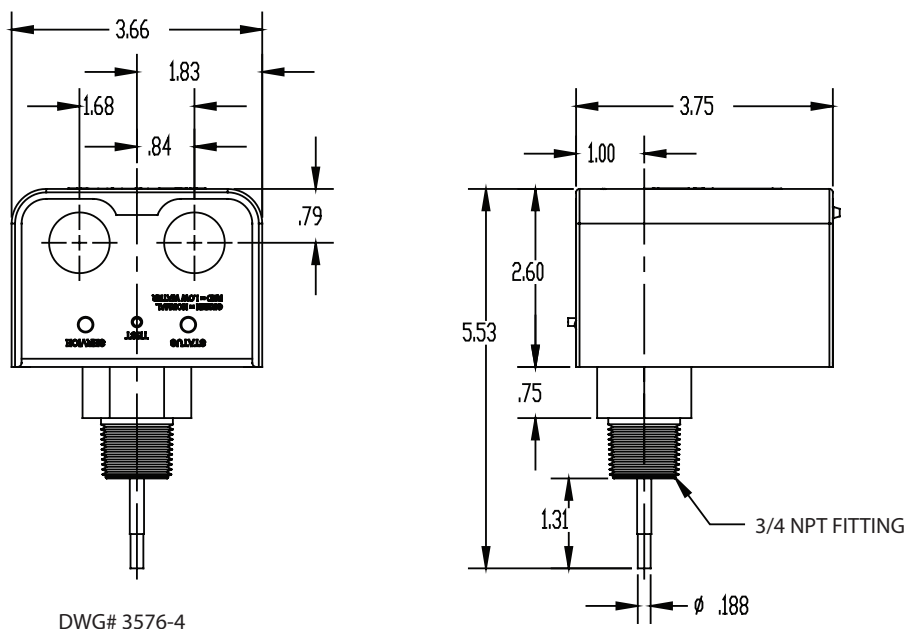

**LWCO WIRING DIAGRAM USING BURNER CIRCUIT POWER SOURCE FIG. 6**

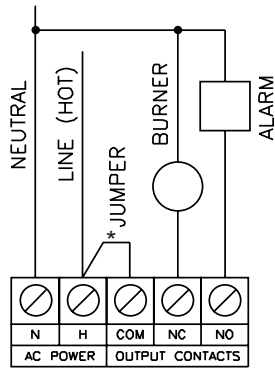

DWG. #1108-5

\*Factory Installed

**LWCO WIRING DIAGRAM USING POWER SOURCE OTHER THAN BURNER CIRCUIT FIG. 7**

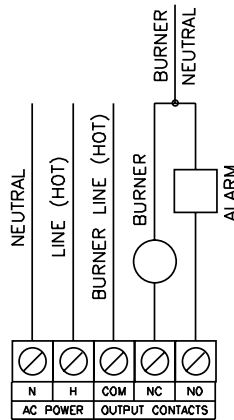

DWG. #1108-6

**TERMINAL BLOCK CONNECTIONS CLAMPING PLATE TERMINAL FIG. 8**

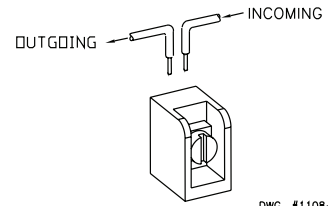

DWG. #1108-10

**CAUTION**

Wire insulation must be rated at 167° F (75° C) or greater. Use at least 18 AWG copper conductors, or as required by code. Use of other wire or insulation types could result in fire causing property damage or serious injury.

**NOTE:** For 24 VAC LTA-2 models, LTA0243S-2, 24 VAC to be supplied by an **EXTERNAL** Class 2 power source to terminals H and N. For 120 VAC LTA-2 models, LTA1203S-2, 120 VAC is supplied by an external circuit to terminals H and N.

**LWCO Wiring Using the Burner Circuit Power Source (See Fig. 6):**

1. Connect the hot lead wire from the power source to terminal **H**.
2. Connect the neutral lead wire from the power source to terminal **N**.
3. Verify that factory installed jumper is present or connect an 18 AWG (min.) jumper wire from terminal **H** to terminal **COM**.

4. Connect the neutral wire of the power source to the neutral side of the burner circuit. Connect wire from the hot side of the burner circuit to terminal **NC**.
5. Connect the neutral wire of the power source to the neutral side of a water feeder or alarm. Connect wire from the hot side of the water feeder or alarm to terminal **NO**.

**LWCO Wiring Using a Power Source Other than Burner Circuit (See Fig. 7):**

1. **Remove Factory installed jumper.**
2. Connect the hot lead wire from the separate power source to terminal **H**.
3. Connect the neutral lead wire from the separate power source to terminal **N**.
4. Connect the hot lead wire from the burner circuit power source to terminal **COM**.
5. Connect the neutral wire of the burner circuit power source to the neutral side of the burner circuit. Connect wire from the hot side of the burner circuit to terminal **NC**.
6. Connect the neutral wire of the burner circuit power source to the neutral side of a water feeder or alarm. Connect wire from the hot side of the water feeder or alarm to terminal **NO**.

**CAUTION**

Be sure the power source for Control Unit and burner circuit are the same voltage. Make sure you are not introducing a second voltage source into the burner circuit via the jumper. This will bypass other operating limit, and/or safety controls, which may result in property damage, personal injury, or death.

**Testing:**

1. **DO NOT** fill boiler. Set thermostat to lowest possible setting and turn on electric power to the boiler. On initial start-up, the LTA-2 will indicate a low water condition, which indicates proper function. The "STATUS" LED on the control unit should illuminate RED. The burner should not operate without water in the system.
  2. Fill boiler with water. Once water covers the probe, the "STATUS" LED on the control should turn from RED to GREEN.
  3. Set thermostat to call for heat and verify that the burner ignites.
  4. With the burner aflame, depress and hold the test switch while observing the burner and the "STATUS" LED on the LTA-2. After the "STATUS" LED illuminates RED, the burner should turn off.
  5. Release the test switch and verify that the burner ignites (provided water covers the probe). The "STATUS" LED on the control unit should turn from RED to GREEN.
  6. If burner fails to cutoff or relight, see the Troubleshooting section for details. Otherwise, set the thermostat to its normal setting.
- Once correct operation of the LTA-2 has been tested, test all other safety, limit, and control devices before finalizing system operation.

**Cleaning, Maintenance, and Replacement:**

- Test the operation of the LTA-2 annually, or more frequently, by pressing the "TEST" button. The "STATUS" LED should turn RED and the boiler should shut down.
- Probe must be inspected every 5 years, (or sooner if "SERVICE" LED turns on), for scale build-up or coating. Clean all oils, fluxes, and scale from probe with a clean rag.
- The control unit should be replaced every 15 years. In areas of high humidity, heavy dust, or other airborne contaminants more frequent replacement may be required.

**PROBE CLEANING FIG. 9**

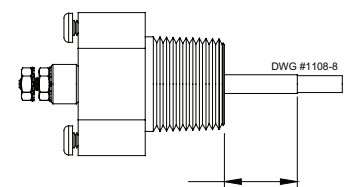

TEFLON SLEEVE INSULATOR (Be careful not to damage during cleaning)

**LTA-2 WIRING CROSS REFERENCE**

		Power Connections		Output Contacts		
Manufacturer	Device or Series	Hot	Neutral	Common	To Burner	To Water Feeder / Alarm
Taco	LN/LTA-2 Series	H	N	COM	NC	NO
McDonnell & Miller	PS-801/851 (Older Models w/Red & Amber LEDs)	1	2	3	5	4
McDonnell & Miller	PS-801/851 (New Models w/Red & Green LEDs)	H	N	C	B	W
McDonnell & Miller	PS-802/852 (Older Models w/Red & Amber LEDs)	H	N	C	B	W
McDonnell & Miller	PS-802/852 (New Models w/Red & Green LEDs)	H	N	C	B	W
McDonnell & Miller	Series 750	1	2	3	4	5
McDonnell & Miller	RB - 122	H (Black Wire)	N (White Wire)	C (Yellow Wire)	B (Yellow Wire)	-
McDonnell & Miller	RB - 120	1	2	3	4	5
McDonnell & Miller	RB - 24	Red Wire	White Wire	Yellow Wire	Yellow Wire	-
Hydrolevel	24	Black Wire	White Wire	-	Orange Wire	Brown Wire
Hydrolevel	170	H	GN	P1	P2	A
Hydrolevel	400, 500, 600, 700, 450, 550, 650, 750	1	2	P1	P2	A
Honeywell	RW700 Series (Except RW700A1098)	L1	L2	-	B	A
Honeywell	RW700A1098	T1	T2	-	B	A

**LWCO Ordering**

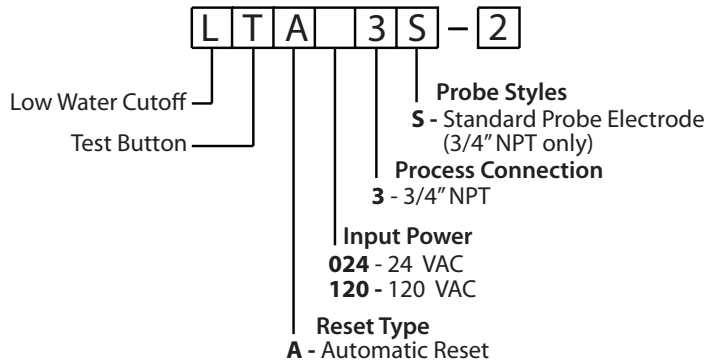

**Probe Only Ordering**

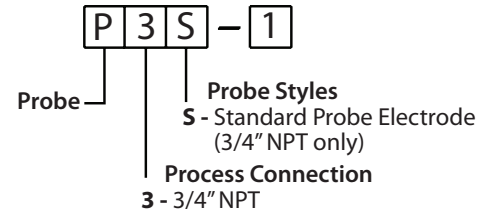

## Troubleshooting:

Symptom	Possible Cause	Remedy
Boiler will not fire	No power to LTA-2	Verify that the LTA-2 wiring is correct. Be sure power to boiler is turned on.
	Low water level	Make sure that the water level has reached the LTA-2 probe.
	Air pocket at LTA-2 probe	Turn off power to the boiler and slowly loosen, but do not remove the LTA-2. Allow any air to escape until water seeps past the LTA-2's threads. Promptly re-tighten the LTA-2 and apply power to the boiler.
	Dirty probe	Fluxes or oils used during the construction of the boiler or installation of system piping can coat the LTA-2 probe, preventing signals from being received by the LTA-2. Add a cleaning solution, (such as water and trisodium phosphate or consult the boiler manufacturer), to the system. Heat and circulate this solution for at least one hour before draining and completely flushing the system with clean water. Remove the LTA-2 probe and thoroughly wipe it with a clean rag. Refill the system and test for proper operation.
	Improper ground	Make sure the green ground wire is electrically common to the boiler. Install the green ground wire to an unpainted/uncoated surface.
	Improper wiring	Check all wiring to the LTA-2 and refer to the wiring diagrams. Using a multi-meter, verify that incoming power is 24 VAC.
	Failed control	If the "STATUS" LED blinks RED, the safety circuits in the LTA-2 have detected a failure in the control. To remove any temporary conditions, turn off power to the LTA-2. After 30 seconds, turn on power to the LTA-2. If the "STATUS" LED continues to blink RED, the control must be replaced.
Boiler will not shutdown	Shorted probe	Turn off power to the boiler and remove the LTA-2. Verify that there is at least 1/4" clearance from all metal surfaces to the metal probe on the LTA-2. Metal from the boiler or piping must not come in contact with the metal probe on the LTA-2.
	Improper wiring	Check all wiring to the LTA-2 and refer to the wiring diagrams. Using a multi-meter, verify that incoming power is 24 VAC for LTA024 models and 120 VAC for LTA120 models.
Amber "SERVICE" LED is on	Dirty probe	Deposits form over time in the system and can coat the LTA-2 probe, preventing signals from being received by the LTA-2. Remove the LTA-2 and thoroughly wipe it with a clean rag. Refill the system and test for proper operation. It may be necessary to clean the boiler and piping as noted above.

### Limited Warranty Statement

Taco, Inc. will repair or replace without charge (at the company's option) any product or part which is proven defective under normal use within one (1) year from the date of start-up or one (1) year and six (6) months from date of shipment (whichever occurs first).

In order to obtain service under this warranty, it is the responsibility of the purchaser to promptly notify the local Taco stocking distributor or Taco in writing and promptly deliver the subject product or part, delivery prepaid, to the stocking distributor. For assistance on warranty returns, the purchaser may either contact the local Taco stocking distributor or Taco. If the subject product or part contains no defect as covered in this warranty, the purchaser will be billed for parts and labor charges in effect at time of factory examination and repair.

Any Taco product or part not installed or operated in conformity with Taco instructions or which has been subject to misuse, misapplication, the addition of petroleum-based fluids or certain chemical additives to the systems, or other abuse, will not be covered by this warranty.

If in doubt as to whether a particular substance is suitable for use with a Taco product or part, or for any application restrictions, consult the applicable Taco instruction sheets or contact Taco at [401-942-8000]. Taco reserves the right to provide replacement products and parts which are substantially similar in design and functionally equivalent to the defective product or part. Taco reserves the right to make changes in details of design, construction, or arrangement of materials of its products without notification.

TACO OFFERS THIS WARRANTY IN LIEU OF ALL OTHER EXPRESS WARRANTIES. ANY WARRANTY IMPLIED BY LAW INCLUDING WARRANTIES OF MERCHANTABILITY OR FITNESS IS IN EFFECT ONLY FOR THE DURATION OF THE EXPRESS WARRANTY SET FORTH IN THE FIRST PARAGRAPH ABOVE. THE ABOVE WARRANTIES ARE IN LIEU OF ALL OTHER WARRANTIES, EXPRESS OR STATUTORY, OR ANY OTHER WARRANTY OBLIGATION ON THE PART OF TACO.

TACO WILL NOT BE LIABLE FOR ANY SPECIAL, INCIDENTAL, INDIRECT OR CONSEQUENTIAL DAMAGES RESULTING FROM THE USE OF ITS PRODUCTS OR ANY INCIDENTAL COSTS OF REMOVING OR REPLACING DEFECTIVE PRODUCTS.

This warranty gives the purchaser specific rights, and the purchaser may have other rights which vary from state to state. Some states do not allow limitations on how long an implied warranty lasts or on the exclusion of incidental or consequential damages, so these limitations or exclusions may not apply to you.

 **Taco Comfort Solutions™** A Taco Group Company

Taco, Inc., 1160 Cranston Street, Cranston, RI 02920 | Tel: (401) 942-8000 | FAX: (401) 942-2360

Taco (Canada), Ltd., 8450 Lawson Road, Suite #3, Milton, Ontario L9T 0J8 | Tel: (905) 564-9422 | FAX: (905) 564-9436

Visit our web site: [www.TacoComfort.com](http://www.TacoComfort.com) | Printed in USA | ©2015 Taco, Inc.

