

## TAPERED REDUCERS — RX40 (No Crimp) RX41 (Crimp)

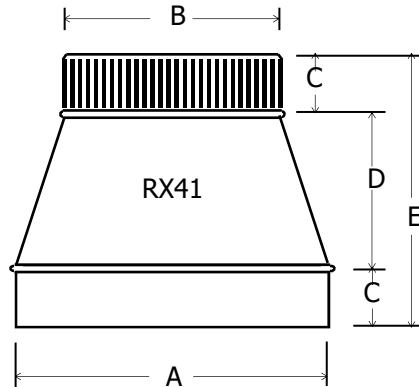
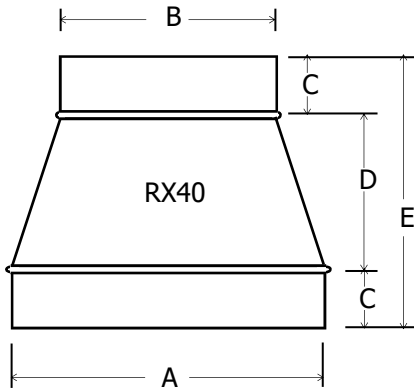

	A	B	C	D	E
4 x 3	4	3	2.0	2.25	6.25
5 x 3	5	3	2.0	3.50	7.50
5 x 4	5	4	2.0	2.25	6.25
6 x 3	6	3	2.0	3.75	7.75
6 x 4	6	4	2.0	2.50	6.50
6 x 5	6	5	2.0	2.50	6.50
7 x 3	7	3	2.0	3.75	7.75
7 x 4	7	4	2.0	4.00	8.00
7 x 5	7	5	2.0	2.75	6.75
7 x 6	7	6	2.0	2.50	6.50
8 x 4	8	4	2.0	4.75	8.75
8 x 5	8	5	2.0	3.50	7.50
8 x 6	8	6	2.0	2.50	6.50
8 x 7	8	7	2.0	2.50	6.50
9 x 6	9	6	2.0	4.00	8.00
9 x 7	9	7	2.0	2.50	6.50
9 x 8	9	8	2.0	2.25	6.25
10 x 6	10	6	2.0	3.25	7.25
10 x 7	10	7	2.0	2.50	6.50
10 x 8	10	8	2.0	2.75	6.75
10 x 9	10	9	2.0	2.50	6.50
12 x 6	12	6	2.0	5.75	9.75
12 x 8	12	8	2.0	4.00	8.00
12 x 9	12	9	2.0	3.50	7.50
12 x 10	12	10	2.0	2.75	6.75

	A	B	C	D	E
14 x 8	14	8	2.0	5.50	9.50
14 x 10	14	10	2.0	5.00	9.00
14 x 12	14	12	2.0	2.75	6.75
16 x 10	16	10	2.0	9.25	13.25
16 x 12	16	12	2.0	6.25	10.25
16 x 14	16	14	2.0	2.75	6.75
18 x 12	18	12	2.0	9.00	13.00
18 x 14	18	14	2.0	6.00	10.00
18 x 16	18	16	2.0	3.00	7.00
20 x 14	20	14	2.0	7.25	11.25
20 x 16	20	16	2.0	6.50	10.50
20 x 18	20	18	2.0	3.00	7.00
22 x 16	22	16	2.0	10.25	14.25
22 x 18	22	18	2.0	7.25	11.25
22 x 20	22	20	2.0	7.25	11.25
24 x 16	24	16	2.0	11.25	15.25
24 x 18	24	18	2.0	10.25	14.25
24 x 20	24	20	2.0	7.50	11.50
24 x 22	24	22	2.0	10.00	14.00

**Standard:** G30 Galvanized, 26GA  
 Riveted construction  
 Machine and hand-rolled air-tite seams  
 G60 and G90, 24 and 22GA available

### PART NUMBER DESIGNATIONS

**RX40xxyy (No Crimp)**

**RX41xxyy (Crimped)**

xx= larger diameter, yy = smaller diameter

PROJECT: _____	COMPANY: _____	DATE: _____
LOCATION: _____	SUBMITTED BY: _____	