

# Reliable®

## Residential Riser

cULus Listed  
175psi (12 bar) rated

### Features

- Stainless Steel body construction
- Factory assembled and tested
- Vertical or horizontal installation
- Optional mounting bracket

### Approvals & Listings

- Listed by Underwriters Laboratories Inc. and Underwriters Laboratories of Canada (cULus)

### Product Description

The Reliable Residential Riser is UL Listed wet-pipe sprinkler system riser assembly consisting of a stainless steel body, waterflow switch, pressure gage, and drain. Triggering Flow is 12 gpm (45 lpm) nominal for the System Sensor waterflow switch and 10 gpm (38 lpm) or more for the Potter Electric waterflow switch. The Residential Riser is intended for use in NFPA 13D and 13R systems, and is offered in 1", 1 1/2", and 2" sizes. The product is available with a variety of end configurations (see table A below), and a choice of drain trims including a three position (off/test/drain) valve with several orifice choices. Optional pressure relief valve kits are also available. The Residential Riser can be wall mounted using the cast-in lugs or stud mounted using the optional support bracket (See Fig. 2).

### Installation

The Reliable Residential Riser should be installed in accordance with NFPA 13, NFPA 13D, or NFPA 13R, as well as the requirements of any authorities having jurisdiction. Failure to follow installation instructions may void the warranty and listing of the valve. Connect the riser manifold to the supply piping and system piping using a non-hardening pipe joint compound or joint sealant tape for threaded connections. Ensure proper direction of flow using the flow arrow cast into the manifold. The one-inch (1") drain should be piped to a location that will avoid damage to property and injury to personnel.



Shown: 2" threaded version with Model TD Test and Drain valve trim, optional Model A Pressure Relief valve kit, and optional locking handle kit (padlock not provided)

### Maintenance

The owner is responsible for maintaining the fire protection system in proper operating condition. Any system maintenance or testing that involves placing a control valve or detection/control system out of service may eliminate the fire protection that is provided by the fire protection system. Notify any required authorities having jurisdiction and implement appropriate precautions prior to proceeding.

When required, the Reliable Residential Riser and associated equipment shall periodically be given a thorough inspection and test. NFPA 25, "Inspection, Testing and Maintenance of Water Based Fire Protection Systems," provides minimum maintenance requirements. Replace any components found to be corroded, damaged, or worn. Increase the frequency of inspections when the valve is exposed to corrosive conditions or chemicals that could impact the valve materials.

**Table A**

Nominal Size	Available End Connections
1" (25mm)	Male or Female NPT
1-1/2" (40mm)	Female NPT or Grooved Ends
2" (50mm)	Female NPT

Basic Assembly with Ball Valve Drain  
(Shown with Optional Pressure Relief Kit)

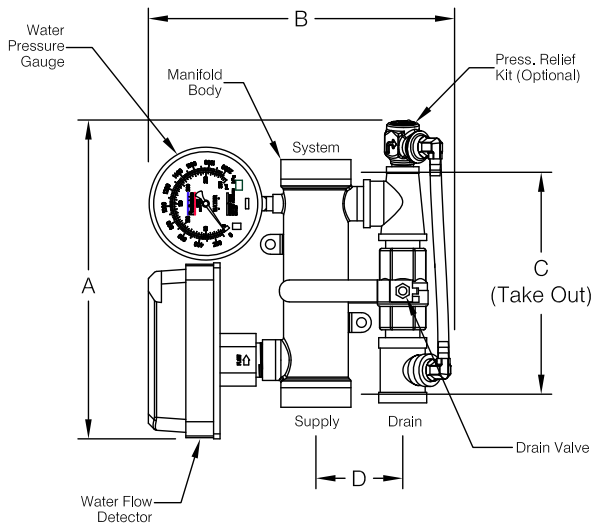

Note: Drain tees are plugged when pressure relief kit is not used.

425FG01

Basic Assembly with Test and Drain Valve  
(Shown with Optional Pressure Relief Kit)

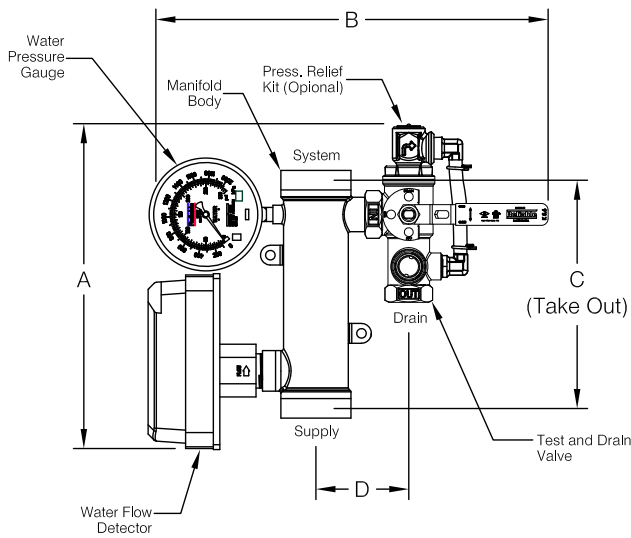

Note: Test and Drain valve outlets are plugged when pressure relief kit is not used.

Dimensions and Weight

Table B

Manifold Size	Basic Assembly with Ball Drain Valve				
	A in (mm)	B in (mm)	C in (mm)	D in (mm)	Weight lbs (kg)
Threaded Female NPT 1 (25)	12-1/4 (311)	11 (279)	8-1/4 (210)	2-3/4 (70)	7.3 (3.32)
Threaded Male NPT 1 (25)		11 (279)	8-1/4 (210)	2-3/4 (70)	7.3 (3.32)
Threaded Female NPT 1-1/2 (40)		11-1/2 (292)	8-1/4 (210)	3 (76)	8.3 (3.77)
Threaded Female NPT 2 (50)		11-3/4 (298)	8-1/4 (210)	3-1/4 (83)	8.8 (4.00)
Grooved Ends 1-1/2 (40)		11-1/2 (292)	9-1/2 (241)	3 (76)	8.3 (3.77)

Dimensions and Weight

Table C

Manifold Size	Basic Assembly with Test & Drain Valve				
	A in (mm)	B in (mm)	C in (mm)	D in (mm)	Weight lbs (kg)
Threaded Female NPT 1 (25)	11-1/4 (286)	14-1/2 (368)	8-1/4 (210)	3-1/4 (83)	9.0 (4.09)
Threaded Male NPT 1 (25)		14-1/2 (368)	8-1/4 (210)	3-1/4 (83)	9.0 (4.09)
Threaded Female NPT 1-1/2 (40)		15 (381)	8-1/4 (210)	3-1/2 (89)	9.7 (4.41)
Threaded Female NPT 2 (50)		15-1/2 (394)	8-1/4 (210)	3-3/4 (95)	10.5 (4.77)
Grooved Ends 1-1/2 (40)		15 (381)	9-1/2 (241)	3-1/2 (89)	9.7 (4.41)

Support Bracket Mount

Figure 2

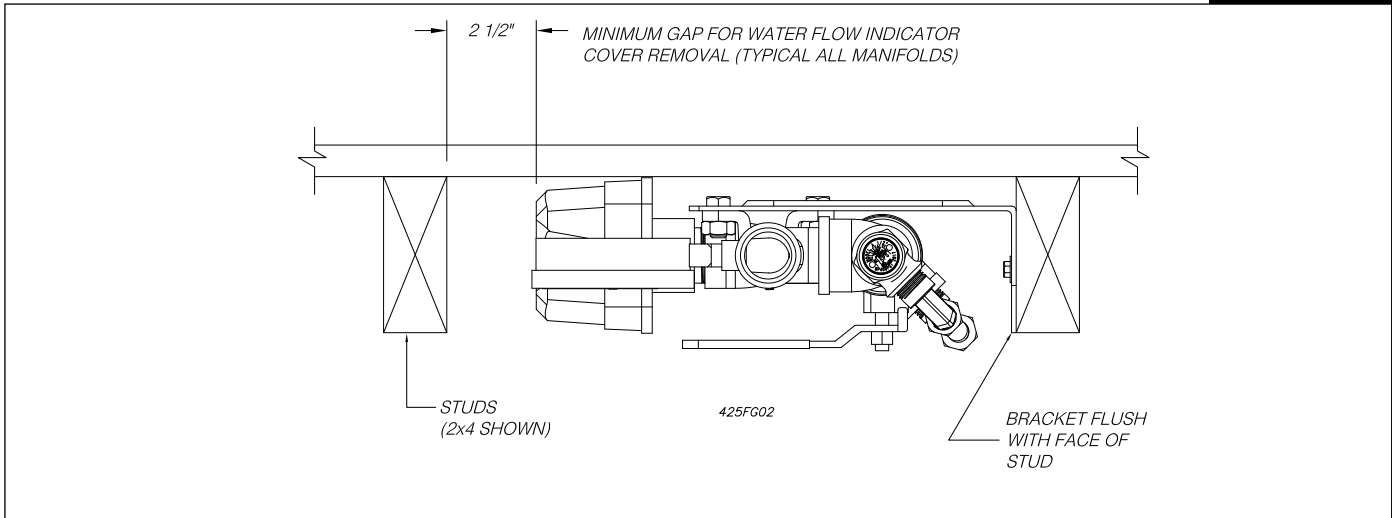

Recessed or Flush Mounted

Figure 3

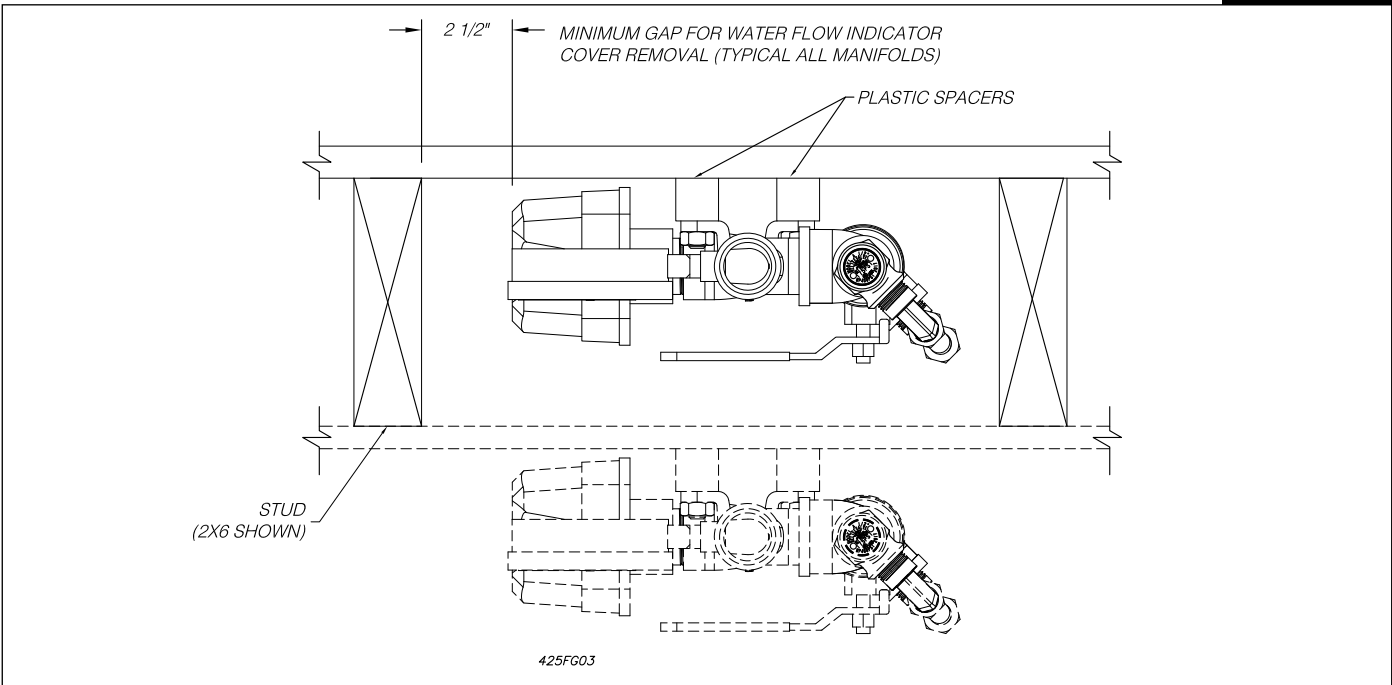

Support Bracket

Figure 4



**6A WW OR X YY Z**

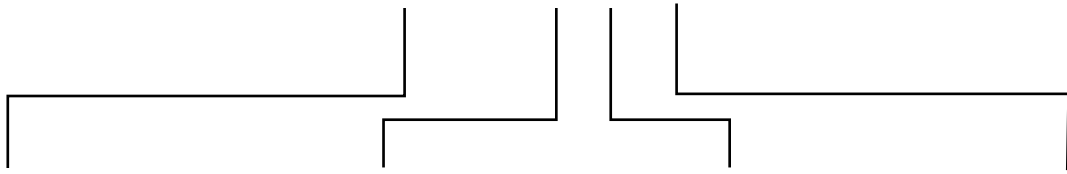

<b>Riser Manifold Size &amp; End Connections <u>WW</u></b>	<b>Waterflow Detector MFG <u>X</u></b>	<b>Drain Valve <u>YY</u></b>	<b>Pressure Relief Kit <u>Z</u></b>
00 = 1" Threaded Female NPT	S = System Sensor	00 = Ball Valve	0 = None
01 = 1" Threaded Female Metric	P = Potter Flow Detector	01 = RASCO Test & Drain (K2.8)	1 = 175 psi (12.1 bar)
02 = 1" Threaded Male NPT		02 = RASCO Test & Drain (K4.2)	2 = 185 psi (12.8 bar)
03 = 1-1/2" Threaded Female NPT		03 = RASCO Test & Drain (K5.6)	
04 = 1-1/2" Threaded Female Metric			
05 = 1-1/2" Grooved End			
06 = 2" Threaded Female NPT			
07 = 2" Threaded Female Metric			

**Example:** P/N 6A020RP031 = 1" Threaded Male NPT End Connection with Potter Flow Detector, RASCO Test & Drain (K5.6), and 175 psi Pressure Relief Kit.

**Replacement Parts & Accessories**

**Table D**

<b>Description</b>	<b>Part Number</b>
Pressure Relief Kit - 175psi	6501203550
Pressure Relief Kit - 185psi	6501203545
Support Bracket Kit	6899190001
System Sensor Waterflow Detector (RFDTHN)	96556910
System Sensor Paddle Tree for Waterflow Detector	96556911
Potter Waterflow Detector (VSR-S)	96556923

**Guarantee**

For Reliable Automatic Sprinkler, Co., Inc. guarantee, terms, and conditions, visit [www.reliablesprinkler.com](http://www.reliablesprinkler.com)