

**Nos. 714 & 914 Self-Opening
Receding Die Heads**

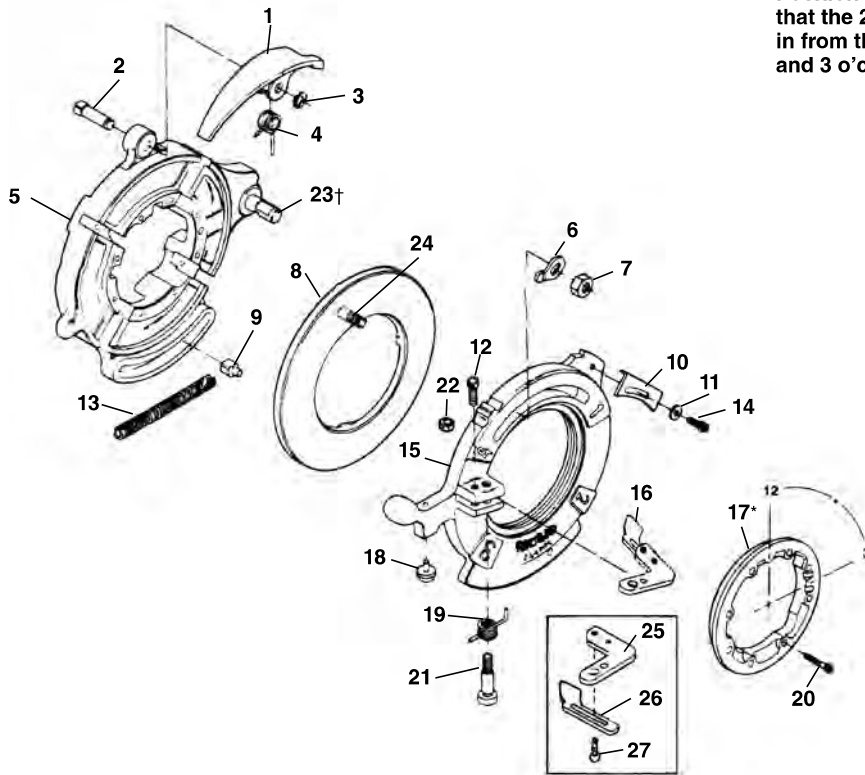

***Position Retaining Ring so that the 2 blind holes coming in from the rear are in the 12 and 3 o'clock positions.**

**NOTE: Order parts by Catalog Number only.
DO NOT order by Reference Number.**

Ref. No.	Catalog No.	Description	Ref. No.	Catalog No.	Description
—	26152	714 Self-Opening Receding Die Head (NPT)	12	27357	Screw 1/4" - 20 x 7/8"
—	26157	914 Self-Opening Receding Die Head (BSPT)	13	26612	Drive Block Spring
—	41387	914 Self-Opening Receding Die Head (BSPT) w/Adjustable Trigger	14	32145	Screw 1/4" - 20 x 1/2"
1	26877	Release Lever	15	26882	Cam Locking Plate
2	26932	Groove Pin	16	26617	Release Foot (NPT)
3	26937	Retaining Ring		32507	Release Foot (BSPT)
4	26872	Spring		32977	Adjustable Release Foot
5	26712	Die Head w/Post	*17	26637	Retaining Ring
6	26957	Lever Washer	18	26962	Sine Bar Ball
7	26887	Hex Nut 7/16" - 20	19	26622	Torsion Spring
8	26952	Cam Assy. (NPT)	20	26642	Screw #10 - 32 x 1 3/8" (8)
	27277	Cam Assy. (BSPT)	21	26627	Shoulder Bolt
9	26632	Drive Block	22	77710	Hex Nut 1/4" - 20
10	26867	Lockout Plate	†23	59827	Post
11	27097	Washer 9/32"	24	33227	Cam Bolt
			25	39992	Release Foot Pivot
			26	39987	Release Foot (BSPT)
			27	32205	Screw
			28	10673	Ball Detente Assy. (4) (Not Shown)

† - See Service Notes

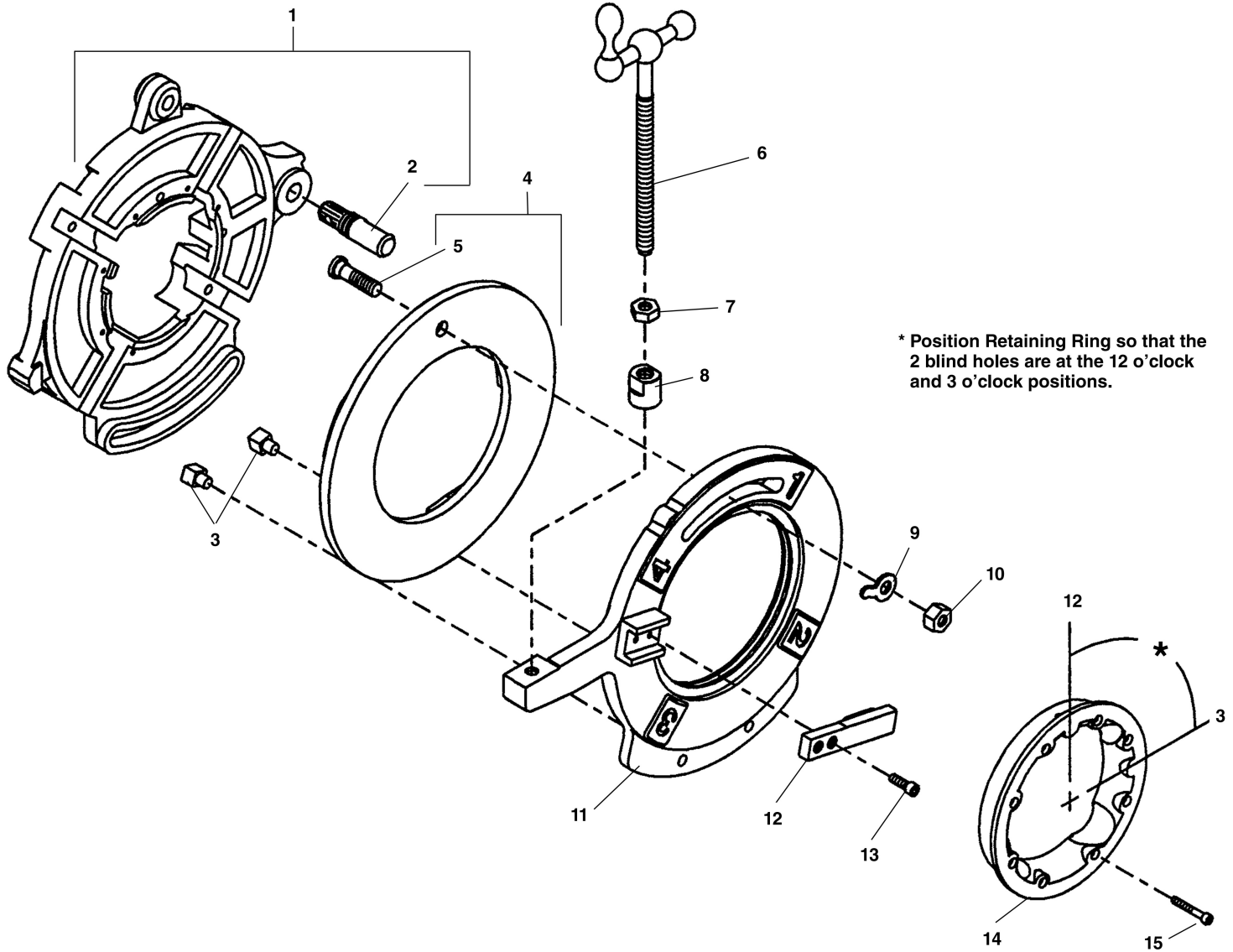

**NOTE: Order parts by Catalog Number only.
DO NOT order by Reference Number.**

Ref. No.	Catalog No.	Description
—	55447	725 Grooving Die Head
1	58687	Die Head With Post
2	59827	Die Head post
3	26632	Drive Block
4	26952	Cam Assembly
5	33227	Cam Bolt
6	58692	Feed Screw Assembly
7	44745	Jam Nut
8	58697	Adjusting Nut
9	26957	Lever Washer
10	26887	Hex Nut $\frac{7}{16}$ " - 20
11	58702	Cam Locking Plate
12	58707	Stop
13	40910	Screw $\frac{1}{2}$ - 20 x $\frac{3}{4}$ " (2)
14	26637	Retaining Ring
15	26642	Screw #10 - 32 x $1\frac{1}{8}$ " (8)

**811A
842
555
531B
532B
500A MONO**

Service Note

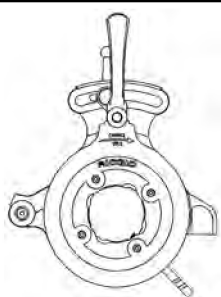

†2 Retaining Ring must be oriented as shown for proper oil flow.

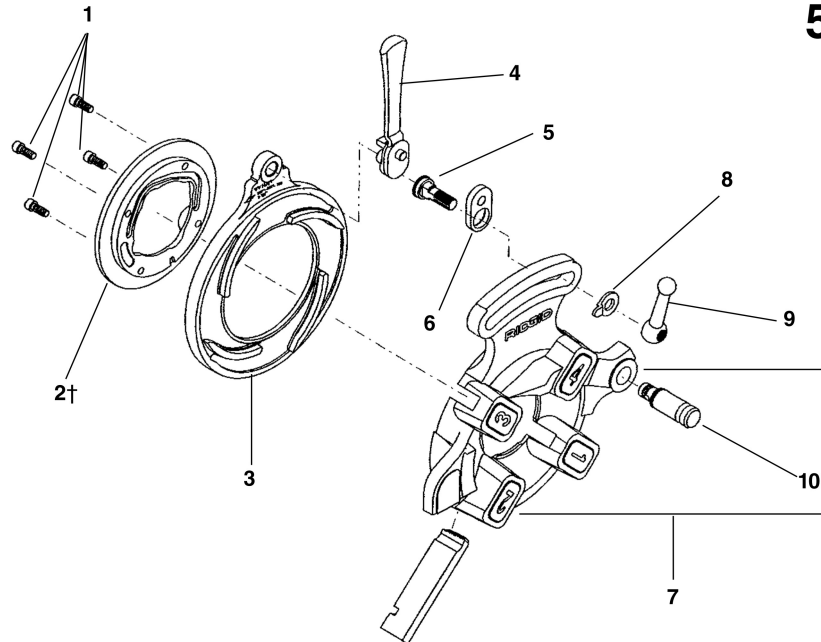

QUICK OPENING DIE HEADS

**NOTE: Order parts by Catalog Number only.
DO NOT order by Reference Number.**

Ref. No.	1	2†	3	4	5	6	7	8	9	10
Die Head & Catalog No.	Screw	Retaining Ring	Cam Plate	Throw-Out Lever	Lock Screw	Link	Head/w Post	Lever Washer	Clamp Lever	Post
811A (97065) 1/8"-2" RH NPT	32205	97020	43360	46520	39860	39950	40922	26957	39970	59832
842 (23282) 1/8"-2" LH NPT	32205	23292	43360	46520	39860	39950	23287	26957	39970	59832
555 (10491) 1/8"-3/4"	32205	24256	43365	46555	39860	39950	24006	26957	39970	59832
531B (97045) 1/4"-1" RH/LH	32205	46620	43405	46555	39955	39950	97055	26957	39970	59832
532B (97050) 1 1/8"-2" RH/LH	32205	46625	43410	46555	39955	39950	97060	26957	39970	59832
811A (97070) 1/8"-2" BSPT	32205	97020	43360	46520	39860	39950	40957	26957	39970	59832
842 (23297) 1/8"-2" LH (BSPT)	32205	23292	43360	46520	39860	39950	23202	26957	39970	59832
500A Mono (1/8"-3/8") RH 1/8" (41032) 1/4" (41037) 3/8" (41042)	32205	1/8"-41862 1/4"-41867 3/8"-41872	43305	46555	47140	39950	41907	26957	46820*	59832
500A Mono (1/2"-3/4") RH 1/2" (41047) 3/4" (41062)	32205	1/2"-41877 3/4"-41882	43300	46555	47140	39950	41912	26957	46820*	59832
500A Mono (1"-1 1/4") RH 1" (41057) 1 1/4" (41062)	32205	1"-41887 1 1/4"-41892	43295	46555	47140	39950	41917	26957	46820*	59832
500A Mono (1 1/2"-2") RH 1 1/2" (41067) 2" (41072)	32205	1 1/2"-41897 2"-41902	43290	46555	47140	39950	41922	26957	46820*	59832

*Hex Nut For Mono Die Heads

610 Die Head – Type 2

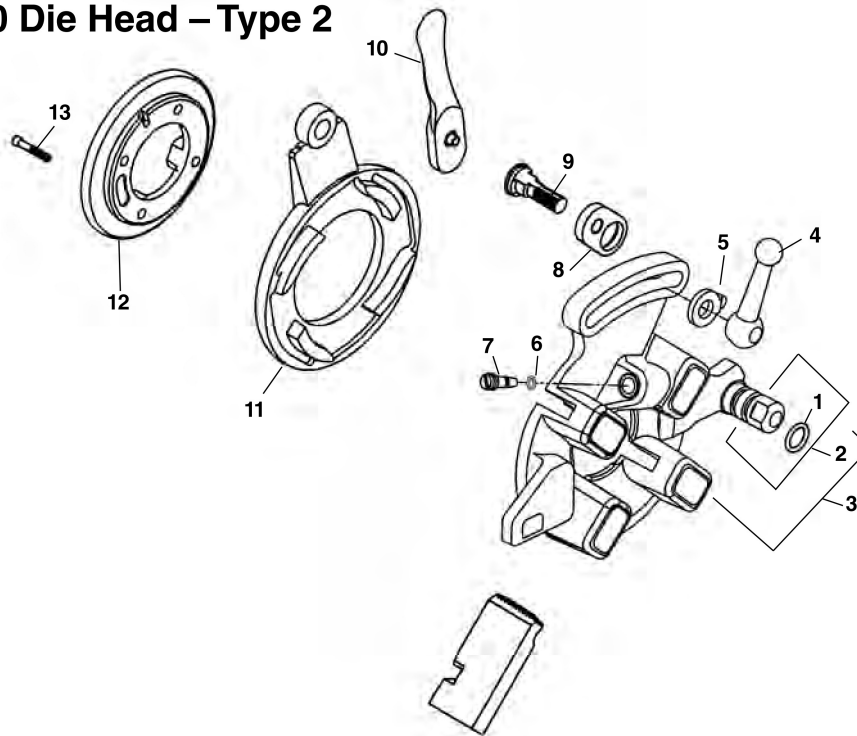

NOTE: Order parts by Catalog Number only.
DO NOT order by Reference Number.

Ref. No.	Catalog No.	Description
—	67817	610 Die Head
1	69392	O-Ring
2	69292	Post
3	69302	Die Head Body w/Post & O-Ring
4	39970	Clamp Lever
5	26957	Washer
6	69182	O-Ring
7	69177	Needle Pin
8	39950	Throwout Link
9	39860	Lock Screw
10	46555	Throwout Lever
11	69442	Cam Plate
12	69352	Retaining Ring
13	32205	Screw 1/4" - 20 x 5/8" Socket Head (4)

354 Cutter

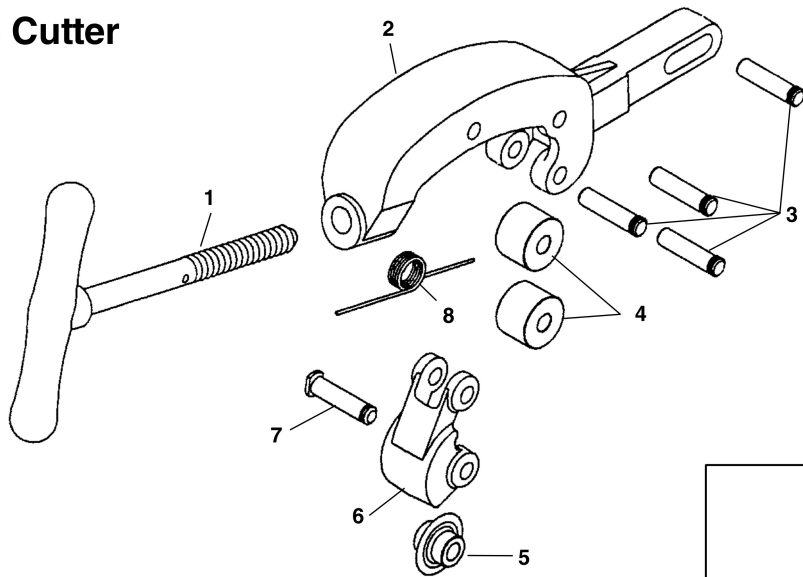

Ref. No.	Catalog No.	Description
—	68877	354 Cutter Assembly
1	69007	Feedscrew & Handle
2	69017	Cutter Frame
3	46662	Roller Pin (4)
4	34775	Roll (2)
5	33105	F3 Cutter Wheel
6	69012	Wheel Housing
7	34780	Pin & Clip
8	58617	Torsion Spring

334 Reamer

Ref. No.	Catalog No.	Description
—	68872	334 Reamer Assembly
1	68997	Screw #8-32 x 7/16" Flat Head
2	68977	Reamer Blade
3	68992	Reamer Arm w/Cone
4	39885	Wave Washer
5	68987	Clevis Pin
6	69002	3/32" x 3/4" Roll Pin

