

No.	DESCRIPTION	MATERIAL
1	STEM	LOW LEAD BRASS ALLOY
2	O-RING	EPDM D2000
3	BALL	LOW LEAD BRASS ALLOY
4	GASKET - SEAL	NITRILE D2000
5	BODY	CAST LOW LEAD BRASS ALLOY
6	O-RING	EPDM D2000
7	END PIECE	CAST LOW LEAD BRASS ALLOY
8	TUBE NUT	CAST BRASS ASTM B62 ALLOY C83600

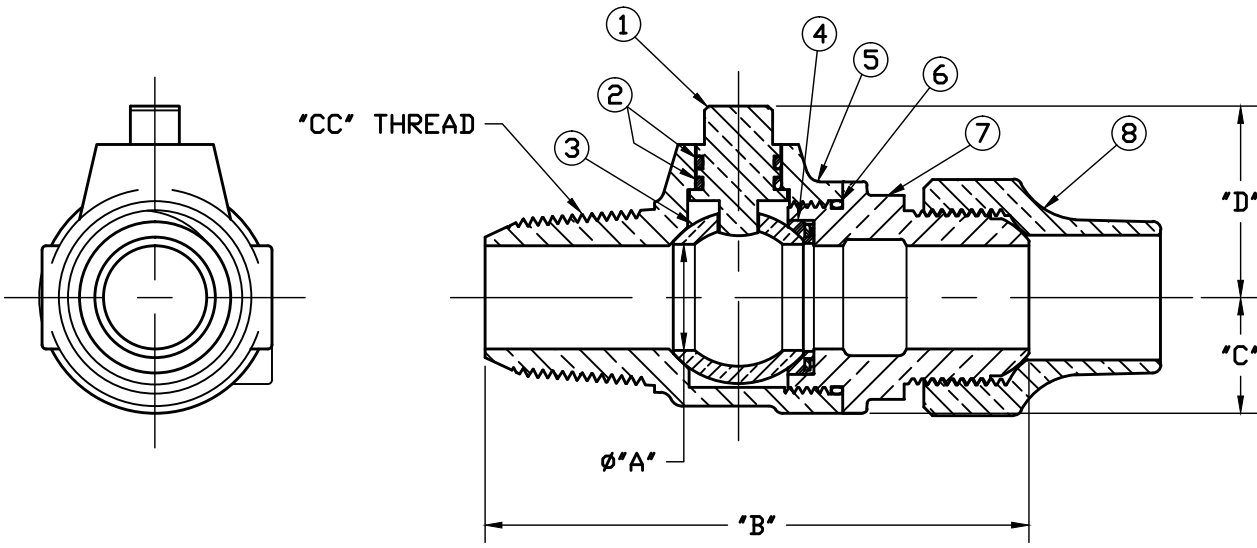

SIZE	ØA	B	C	D
3/4	.75	3.95	.84	1.39
3/4x1	.75	4.08	.84	1.39
1	1.00	4.87	1.15	1.59
1-1/2	1.50	6.11	1.50	2.24
2	2.00	7.21	1.82	2.56

NOTE: ALL WETTED PARTS ARE LOW LEAD BRASS ALLOY

FILEPATH: PROD-ENG/MUELLER/ASYSUBMITTALS/B25000N

				DRFTR	JGarvin	6/3/11	Mueller Co.	
				CHKR				
				ENGR				
				MGR				
				BY	DATE	UNLESS OTHERWISE NOTED		THIRD ANGLE PROJECTION
				STK No:		SURFACE PREPARATION:		REF. No.
				MAT'L:		BREAK CORNER(S) ---- .000		
				DESCR.		SURFACE FINISH -- XX RMS		NONE
				BALL CORPORATION VALVE		TOLERANCE(S):		
				LOW LEAD BRASS('CC' x 'CS')		LINEAR ----- ± .000		PART NUMBER
				PER EST NO: DXXXX EST FIN WT = 0.0000 lbs		ANGULAR ----- ± 0°00'		

PART NUMBER
B25000N
442-MRKTG