

No.	QTY.	DESCRIPTION	MATERIAL
1	1	SPUD	CAST LOW LEAD BRASS ALLOY
2	1	CONN. NUT	CAST BRASS ASTM B62 ALLOY C83600
3	1	CTS GSKT SUB	SBR D2000 - GSKT 410ss - BAND

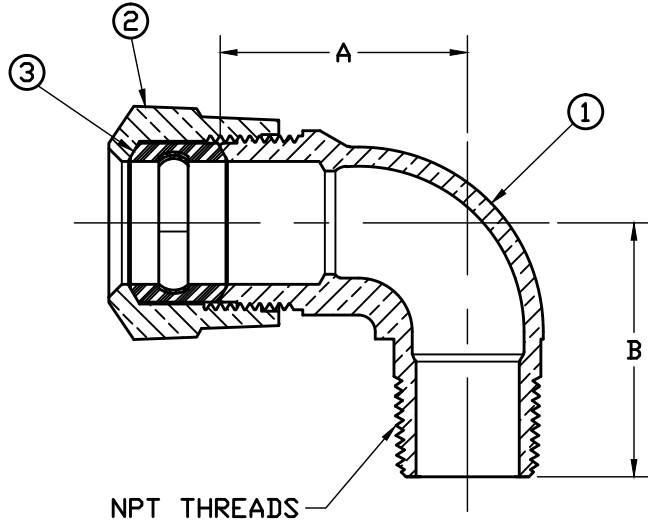

SIZE	A	B
3/4	1.796	1.844
3/4x1	2.000	2.000
1	2.000	2.000
1x3/4	2.000	2.000
1-1/2	2.750	2.625
2	3.094	2.969

**NOTE:** ALL WETTED PARTS ARE LOW LEAD BRASS ALLOY

FILEPATH: PRODD-ENG\MUELLER\ASYSUBMITTALS\H15531N

						DRFTR Garvin 12/21/09	<b>Mueller Co.</b>				
						CHKR			UNLESS OTHERWISE NOTED SURFACE PREPARATION: BREAK CORNER(S) ---- .000 SURFACE FINISH -- XX RMS TOLERANCE(S): LINEAR ----- ± .000 ANGULAR ----- ± 0°00'	THIRD ANGLE PROJECTION ⊕    ▸	
						ENGR					REF. No.    SCALE NONE
						MGR					
						BY    DATE					
						STK No:					
						MAT'L:					
REV	ECR	DESCRIPTION	DATE	BY	CHKR	DESCR.	PART NUMBER				
						QUARTER BEND SERVICE FITTING LOW LEAD BRASS (110 CTS x MIP)	H15531N				
PER EST NO: DXXXX EST FIN WT = 0.0000 lbs											

PART NUMBER  
H15531N  
442-MRKTG