

NOTES:

- (N1) 1. FIT / FORM / FUNCTION SHALL FOLLOW PS-E.008.
- 2 COMPLY WITH ASME A112.18.2
- 3 MINIMUM DRAIN RATE 7.0 GPM (27L/MIN).
- △ 4 MINIMUM WATER SEAL DISTANCE.
- 5 P-TRAP CAPABLE TO ACCOMODATE A 1.25 +.008/- .000 TUBE SIZE.
- 6 LEAK TEST:
SEALS USED IN P-TRAP SHALL BE SUBJECTED TO A STATIC PRESSURE OF 20 IN. (500 mm) WATER COLUMN, USING COLD WATER, FOR A PERIOD OF 5 MIN. AND SHALL SHOW NO SIGNS OF LEAKAGE.
- △ 7 ITEMS 3 AND 11 ARE OPTIONAL PARTS, ONLY INCLUDED WHEN ASSEMBLY IS SUPPLIED FINISHED AND PLATED. DO NOT INCLUDE ITEMS 3 AND 11 IF PURCHASED AS UNASSEMBLED (INDIVIDUAL COMPONENTS) AND RAW.
- △ 8 OPTIONAL PART USED TO ACCOMODATE $\varnothing 1-1/2"$ CONNECTION.

BILL OF MATERIAL (CURRENT LEVEL)				
ITEM	PT/ASSY	DESCRIPTION	TYPE	QTY.
1	51004	BODY	PART	1
2	50882	TRAP PLASTIC	PART	1
3	50883	TRAP BRASS	PART	1
4	50881	PLUG CLEAN OUT	PART	1
5	91512	O-RING, .07 X 1.5 ID	PART	1
6	50880	NUT	PART	1
7	50878	TUBE	PART	1
8	50879	NUT	PART	1
9	91691	WASHER	PART	1
10	50884	CAP	PART	1
11	91192	WSHR, 1.23 ID X 1.715 OD X .24 THK, CONTEMP, PLY I	PART	1

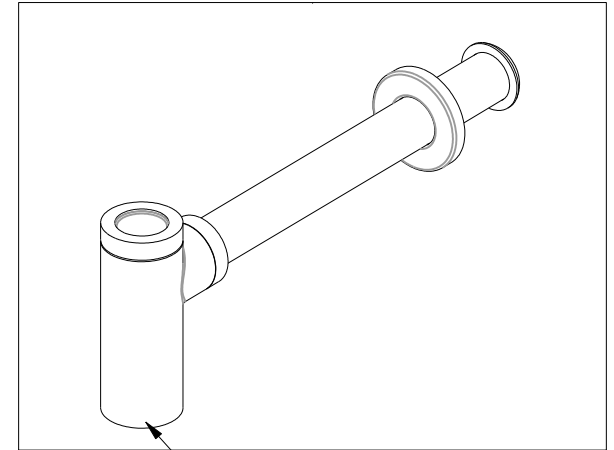
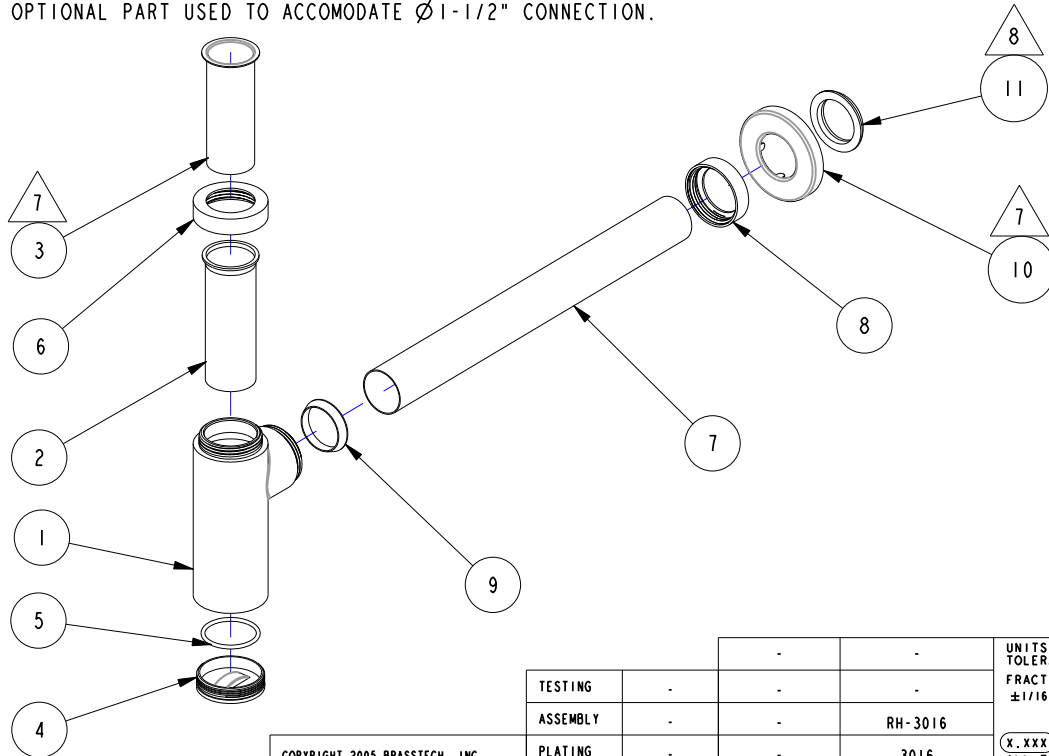

AFFIX LABEL # 98132
APPROX WHERE SHOWN

TESTING	-	-	-
ASSEMBLY	-	-	RH-3016
PLATING	-	-	3016
POLISHING	-	NEXT ASSY	USED ON
MACHINING	-	APPLICATION	
TOOLING FIXTURE #	REMOVE ALL BURRS AND SHARP EDGES		

UNITS ARE: INCHES [MM]
TOLERANCES ARE:
FRACTIONS DECIMALS ANGLES
 $\pm 1/16"$.X $\pm .1$ [2.5] $\pm 1"$
.XX $\pm .06$ [1.5]
(X.XXX) DENOTES CRITICAL DIMS.
ALL THREADS ARE CRITICAL

BRASSTECH 2001 CARNEGIE AVE.
INCORPORATED SANTA ANA, CA 92705
(949) 417-5207

CONTEMPORARY P TRAP, ROUND

-	D	EN-3001	01/13/16	N.S.
ZONE	REV	DESCRIPTION	DATE	APPROVED

COPYRIGHT 2005 BRASSTECH, INC.
THESE DRAWINGS AND THE DESIGNS
DEPICTED HEREIN ARE THE PROPRIETARY
PROPERTY OF BRASSTECH. ANY USE
OR REPRODUCTION IS SUBJECT TO
THE EXPRESS APPROVAL OF BRASSTECH.
UNAUTHORIZED USE IS STRICTLY
PROHIBITED. ALL RIGHTS RESERVED.

DRAWN H .LE 08/11/04
CHECKED V. VU 08/11/04
APPROVED V. VU 08/11/04

DWG NO. 301-2
SCALE .220 REF. - SHEET 1 OF 2

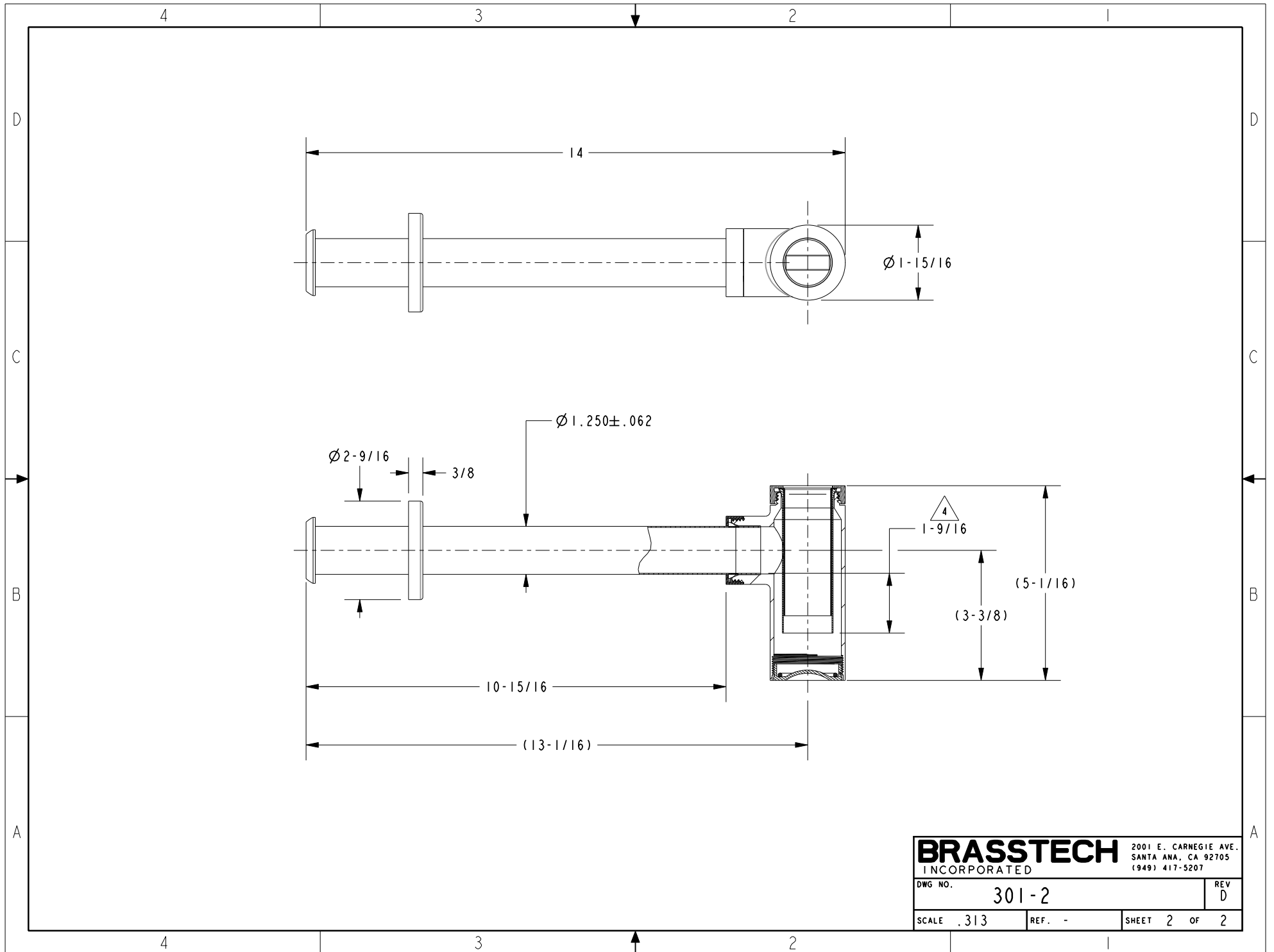

BRASSTECH		2001 E. CARNEGIE AVE.	
INCORPORATED		SANTA ANA, CA 92705	
		(949) 417-5207	
DWG NO.	301-2	REV	D
SCALE	.313	REF.	-
		SHEET	2 OF 2