

Food Waste Disposers



Submittal Sheet

This popular model offers the following features and benefits:

- 1/2 Horsepower Heavy Duty Motor (Quiet Dura-Drive® Induction Motor)
- *We Come To You*® 2-Year In-Home Limited Warranty
- Rugged Galvanized Steel Construction (For Disposer Durability)
- Space-Saving Compact Design
- Available with or without a factory installed power cord.

Specifications

Type of Feed	Continuous
On/Off Control	Wall Switch
Motor	Single Phase
HP	1/2
Volts	120
HZ	60
RPM	1725
Amp. (Avg. Load)	6.3
Time Rating	Intermittent
Lubrication	Permanently Lubricated Upper & Lower Bearings
Shipping Weight (Approx.)	13 lbs. 10 oz. (without cord) 13 lbs. 14 oz. (with cord)
Unit Finish	Condor Grey
Overall Height	11-1/2"
Grind Chamber Capacity	26 oz.
Motor Protection	Manual Reset Overload
Average Water Usage	Approx. 1 Gallon per Person Per Day
Average Electrical Usage	3-4 KWh per Year
Drain Connection	1-1/2" Cushioned Slip Joint
Dishwasher Drain Connection	Yes
Factory Installed Power Cord	Available with or without

Dimensions

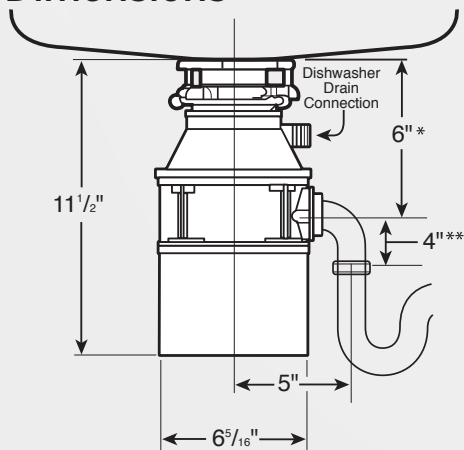

- * Distance from bottom of sink to center line of disposer outlet. Add 1/2" when stainless steel sinks are used.
 - ** Length of tailpipe from center line of disposer outlet to end of tailpipe.
- NOTE: Plumb waste line to prevent standing water in disposer motor housing.

Sample Specification

Food Waste Disposer(s) shall be InSinkErator Badger® 5, continuous feed, with 1/2 H.P. motor, galvanized steel grinding elements with two stainless steel 360° swivel lugs. Self-service wrench.

Available with or without a factory installed power cord.

Warranty:
2-Year parts and in-home service.

* The complete InSinkErator warranty is included in the Care & Use Booklet packed with each unit.



Food waste disposers can provide an environmentally responsible alternative to transporting food waste to landfills. And they can help reduce greenhouse gas emissions. At capable wastewater treatment plants, food waste can be recycled to produce renewable energy. Additionally, capable wastewater treatment plants can process food waste into fertilizer. (Check the plant in your area.)

Job Specifications

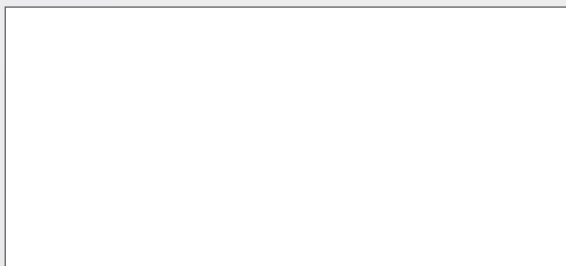

The Emerson logo is a trademark and service mark of Emerson Electric Co. The mounting collar configuration is a trademark of Emerson Electric Co.

1-800-558-5700
www.insinkerator.com

InSinkErator may make improvements and/or changes in the specifications at any time, in its sole discretion, without notice or obligation and further reserves the right to change or discontinue models.