

SUBMITTAL DATA SHEET

NL Plug Style Corporation Stop – 73149

MNPT x FNPT

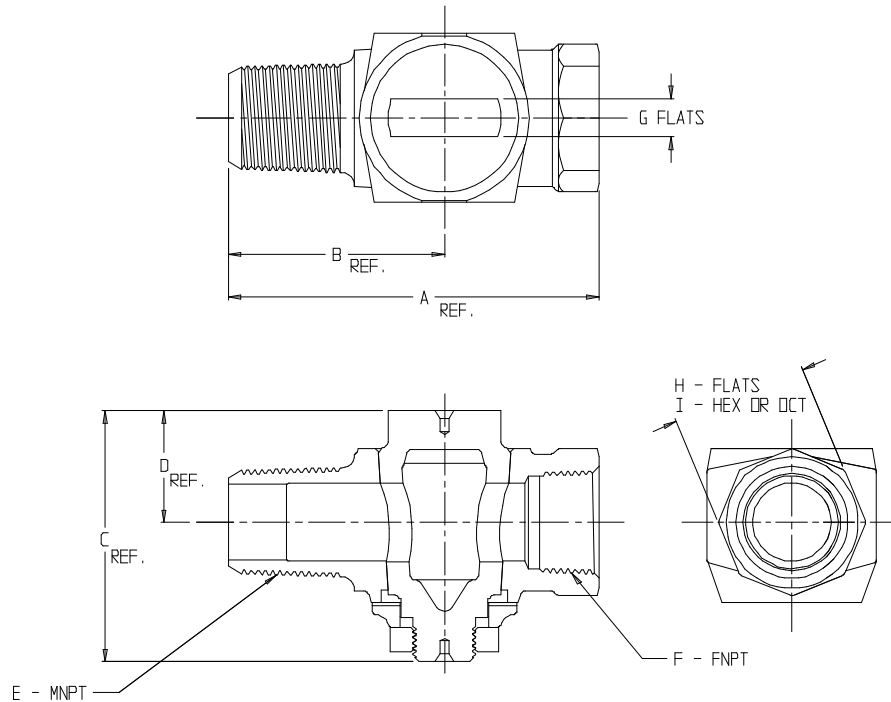

MODEL	SIZE	A	B	C	D	E	F	G	H	I
73149	3/4	3.69	2.15	2.50	1.11	3/4	3/4	.38	1.36	OCT
73149	1	4.33	2.40	2.89	1.41	1	1	.38	1.59	HEX

SUBMITTAL INFORMATION

- Manufactured in compliance with ANSI/AWWA C800 (latest revision)
- Brass components in contact with potable water conform to ASTM B584, UNS C89833 (latest revision) and identified with “NL”
- Certified to NSF/ANSI 61 and NSF/ANSI 372
- Brass components not in contact with potable water conform to ASTM B62 and ASTM B584, UNS C83600 -85-5-5-5 (latest revision)
- Large wrench flats provided for proper installation
- Plug rotates 360°
- 1/2” – 1” rated for 100 PSIG water pressure
- 1 1/4” – 2” rated for 80 PSIG water pressure



A.Y. McDonald Mfg. Co.
P.O. Box 508
Dubuque, IA 52004-508

Toll Free: 1-800-292-2737
Fax: 1-800-832-9296
Hours: 7:00 a.m. – 5:00 p.m., CST

sales@aymcdonald.com
www.aymcdonald.com

A.Y. McDonald considers the information on this assembly drawing correct when published. Item and option availability, including specifications, are subject to change without notice.

Submitted by: