



HTP 30 Evacuated Tube Collector HP-30SC

ITEM: Solar collector unit for heating water or glycol/ water for exterior installation on roof or ground

TYPE: Evacuated glass tube type collectors in a unitary, multiple-tube assembly frame

PROCESS: Internal heat pipe containing phase change fluid absorbs solar radiant heat and conducts it up to a condenser element where heat is transferred indirectly through dry sockets to an insulated, manifolded header pipe containing separate system heat transfer fluid.

SUPPORT FRAME:

- Frame or rack material is extruded aluminum with stainless steel hardware and fittings,
- Frame angle is fixed at a site-selected angle, on site.
- Frame type: Singular interconnected frame for a 4 collector unit rack, or, modular frames that are predesigned to be interconnected to adjacent frames to form a 4 collector unit rack.

EVACUATED TUBES:

- Number of tubes: 30 tubes per collector unit
- Length of a typical tube: approximately 6.5 ft.
- Aperture area: 30.03 ft² per 30-tube unit
- Glass Material: Double layer of Borosilicate Glass with evacuated space between
- Stagnation Temperature: Approximately 420 Degrees F without insulation degradation,

tube cracking or hazing, phase change fluid breakdown, or condensing element warpage.

- Absorption efficiency: 92%
- Low E and absorptive coatings: Al-N, SS and Cu applied by metal deposition or metallic sputtering processes. Exact materials may vary or may be a proprietary blend.

HEAT PIPE: Aluminum or copper with copper or nickel plated copper condenser bulb with no mechanical or moving parts. Phase change fluid is water and/or proprietary chemicals.

UNIT: Weight: 255 lbs+/- per 30 tube unit

INSTALLATION

WARRANTY

10 years for any failure of tubes, frame and/or manifold under normal usage conditions (exception taken for abuse, neglect, and accidental or willful damage) on systems installed per manufacturer's recommendations with technical assistance by manufacturer's representative. 10 year warranty with installation by a certified installer.

CERTIFICATION

Solar Rating and Certification Corporation (SRCC)
Certified: OG100

Suggested Specifications:

Evacuated tube collectors use a vacuum space within each tube's borosilicate glass shell to offer unsurpassed efficiency and heat loss protection in any climate. In the event of a tube breaking, it can be removed and the entire system will continue to function, ensuring a heating source that will not fail.

There are four unique heat pipe evacuated tube models allowing HTP solar collectors to be sized for any solar heating application, including residential, commercial, municipal, agricultural and industrial systems. HTP solar collectors are independently tested and certified by the world's leading solar energy authorities to ensure that each product is a global leader in reliability, heat output, and return on investment.

Collectors are SRCC certified, Solar Keymark certified, and come with a 10 year warranty if installed by a certified installer. They come with multiple mounting and installation options suitable for flat and pitched roofs.

HP-30SC Collector Specifications

Model	HP-30SC
# of Tubes	30
Dimensions (in)	101 x 79
Weight (lbs.)	252
Net Aperture Area (ft ²)	30.04
Storage Tank Size (G)	70+
Nominal Flow Rate (G/min)	0.84

Evacuated Tube collectors use a vacuum space within each tube's borosilicate glass shell to offer unsurpassed efficiency and heat loss protection any climate. In the even of a tube breaking it can be removed and the entire system will continue to function, ensuring a heating source that will not fail.

Efficiency curve with measurement points based on aperture area .936 msq

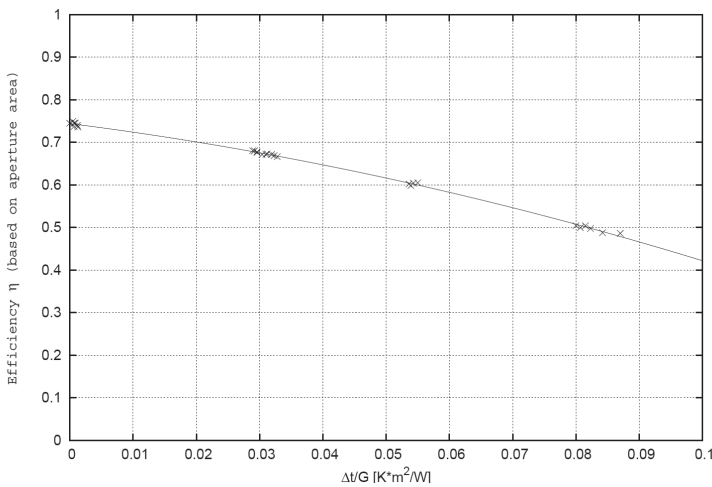

Results:

The calculated parameters are based on following areas: aperture area of 0.936 m²: absorber area of 0.808 m²:

$$\eta_{0a} = 0.734 \qquad \eta_{0A} = 0.850$$

$$a_{1a} = 1.529 \text{ W/m}^2\text{K} \qquad a_{1A} = 1.771 \text{ W/m}^2\text{K}$$

$$a_{2a} = 0.0166 \text{ W/m}^2\text{K}^2 \qquad a_{2A} = 0.0192 \text{ W/m}^2\text{K}^2$$



Series Specifications

Tube Length	70"
Outer Tube Diameter	2.2"
Inner Tube Diameter	2.1"
Tube Thickness	0.1"
Tube Material	Borosilicate Glass
Tube Coating	Al - N/Al
Thermal Expansion	3.3 x 10 ⁻⁶
Absorption Efficiency	> 92%
Emittance	< 8%
Vacuum P	< 5x10 ⁻³ Pa
Heat Loss	< 0.7 W/m ² C
Maximum Strength	1.0 MPa
Stagnation Temperature	> 428 °F
Flow Rate	0.028 GPM/tube
Fittings	1" NPT
Warranty	10 Years

Certifications:

The HTP Evacuated Tube Heat Pipe Solar Collectors were SRCC Certification at the FSEC Institute in Florida. While SRCC Certification is not mandatory to sell, purchase or install a Solar Hot Water System, the Certification does bring several significant benefits to HTP Solar Hot Water customers across the United States. These collectors are also Keymark Certified, an important certification in Europe.

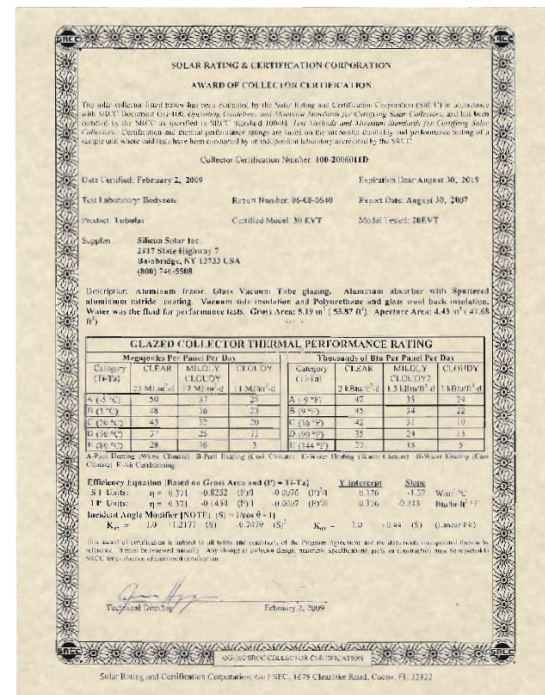

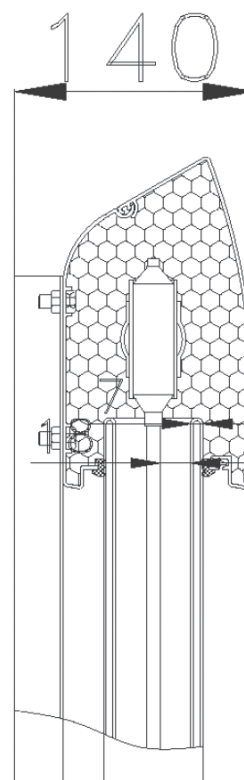
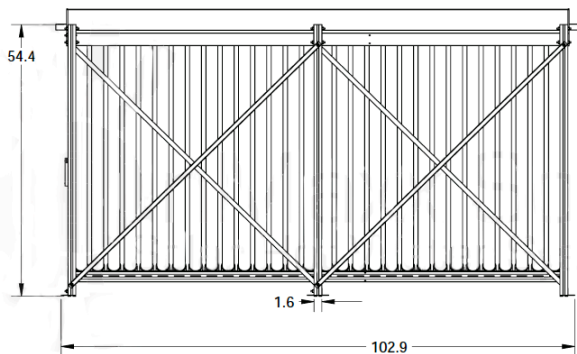
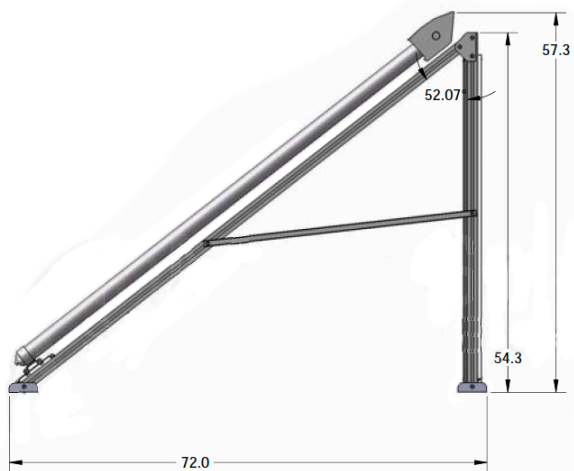
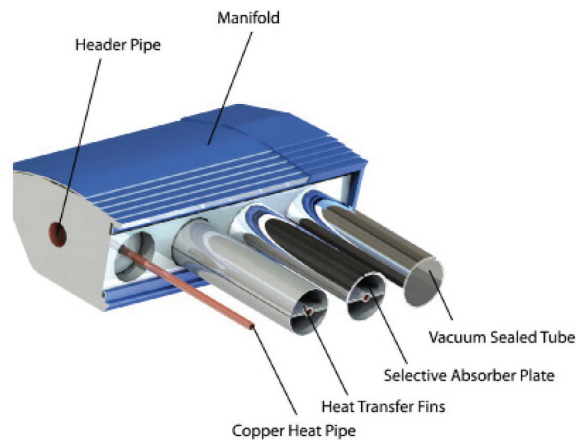
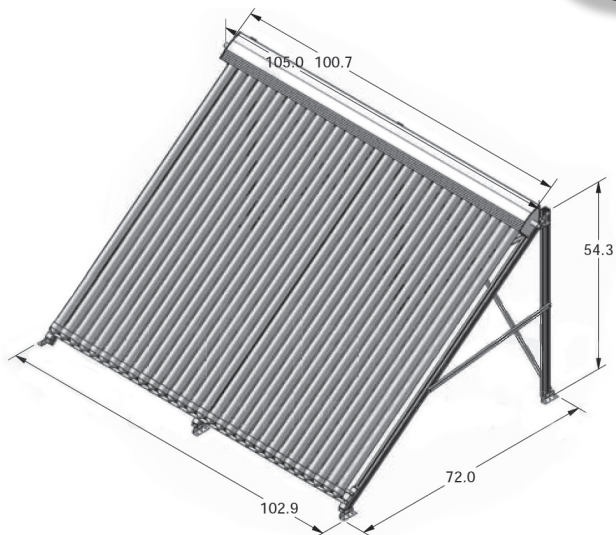

System Overview:



Approval Stamps

Architectural Stamps and Remarks

Contractor Stamp and Remarks

Contractor Note - Sign Below