

INSTALLATION AND MAINTENANCE INSTRUCTIONS

IM-2-502-US

July 2008

TD42

Description

The TD42L and TD42H are maintainable thermodynamic steam traps with integral strainer. The TD42L is specifically designed for relatively small condensate loads and therefore is ideal for main drainage applications. For process type loads the TD42H is available.

All traps have external body surfaces with an electroless nickel plate (ENP) finish which is oxidation resistant.

Operation

The TD42 is a Thermo-Dynamic® steam trap which uses a disc to control the release of condensate and to trap steam. The trap cycles open and closed to discharge condensate close to steam temperature and closes tight between discharges.

The disc, which is the only moving part, rises and falls in response to dynamic forces produced by the partial re-evaporation (flashing) of hot condensate. Cool condensate, air and other noncondensable gases enter the trap through the central orifice, lift the disc, and are discharged through the three outlet orifices. When the condensate approaches steam temperature, a portion of it flashes as it enters the trap. The flash steam passes at high velocity over the underside of the disc and collects in the control chamber above. The resulting pressure imbalance forces the disc downward onto the seating surfaces, stopping the flow. The trap remains tightly closed until pressure in the chamber is decreased through condensation of the flash steam, allowing inlet pressure to raise the disc and repeat the cycle.

Limiting Operating Conditions

Max. Operating Pressure (PMO)	600 psig (42 barg)
Min. Operating Pressure	3.5 psig (0.25 barg)
Max. Return Line Pressure (Backpressure)	80% of trap inlet pressure
Max. Operating Temperature	752°F (400°C) at all operating pressures

Installation

Full-flow isolating valves should be installed so as to permit the isolation of the trap from both supply and return line pressure.

The trap will operate in any position, but the preferred installation is in a horizontal pipe.

Maintenance

This product can be maintained without disturbing the piping connections. Complete isolation of the trap from both supply and return line pressure is required before any service can be performed. If a blowdown valve is installed, it should be opened to release any residual pressure.

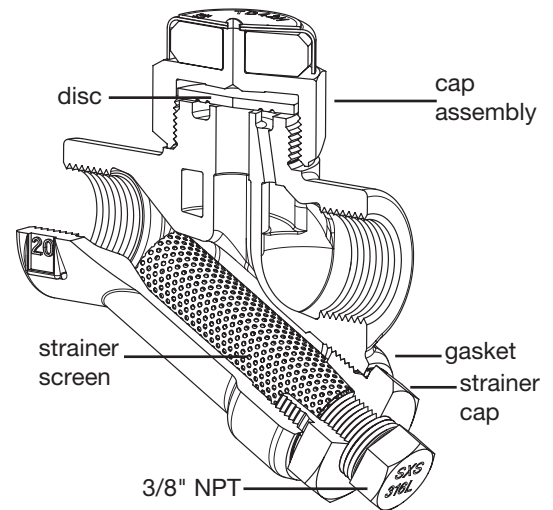

Remove the cap. If the disc and body seating faces are only slightly worn they can be refaced by lapping individually on a perfectly flat surface such as a lapping plate.

If the wear is too great to be rectified by simple lapping, the seating faces on the body must be ground flat and then lapped and the disc replaced. The total amount of metal removed in this manner should not exceed 0.010" (.25 mm).

The disc is replaced with the groove side down. A small amount of high-temperature anti-seize compound should be applied to the cap threads on the body, and the cap tightened to the torque listed below.

Operation of Blowdown Valve (if supplied)

Hand protection is recommended before discharging the blowdown valve.

While holding the blowdown cap stationary, rotate the blowdown screw counterclockwise to release the contents of the strainer. The valve will discharge through the center of the valve, therefore precaution must be taken to keep clear of this area.

When finished, rotate the blowdown screw clockwise to sealing. Do not over torque. Tighten just enough to stop flow.

To Clean or Replace the Strainer

Complete isolation of the trap from both supply and return line pressure is required before any service can be performed.

Unscrew the strainer cap, withdraw the screen and clean. If the screen shows any signs of damage, replace it immediately.

To re-assemble, place strainer cap gasket over thread and insert the screen in the cap, then screw the cap into place. A fine smear of Molybdenum Disulphide grease should be applied to the threads.

Recommended Tightening Torques	
Cap Assembly	100-110 ft•lb (135-150 Nm) all TD42L
Cap Assembly	134-148 ft•lb (180-200 Nm) all TD42H
Strainer Cap	126-144 ft•lb (170-190 Nm)
Blowdown Valve	50 ft•lb (68 Nm)

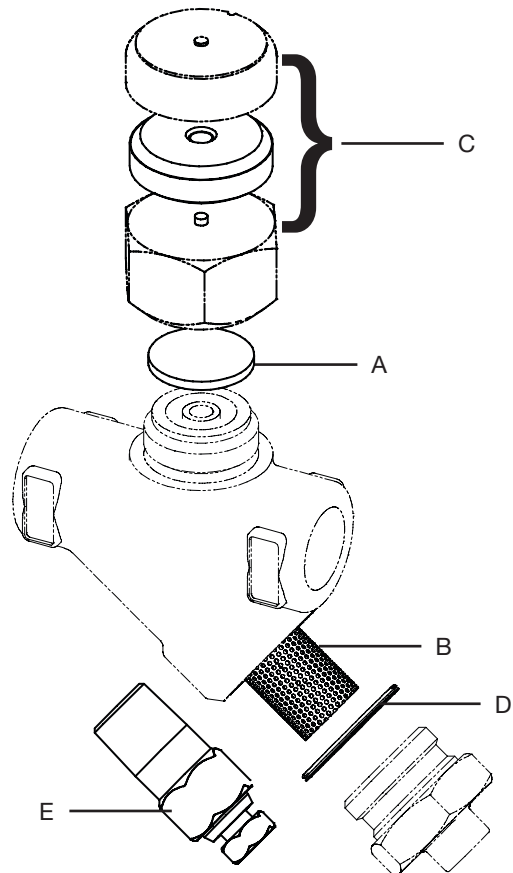

Disc (pkt of 3)	A
Strainer Screen & Gasket	B, D
Insulcap Assembly	C
Gasket (Set of 3)	D
Blowdown Valve	E

Available spare parts are shown in heavy line. Parts drawn in broken line are not supplied as spares.

Spirax Sarco Technical Support Department
Toll Free at: 1-800-833-3246

spirax
/sarco

SPIRAX SARCO, INC. • 1150 NORTHPOINT BLVD. • BLYTHEWOOD, SC 29016
PHONE 803-714-2000 • FAX 803-714-2222
www.spiraxsarco.com/us