

No.	DESCRIPTION	MATERIAL
1	STEM	CAST LOW LEAD BRASS ALLOY
2	O-RING	EPDM ASTM D2000
3	BALL	CAST LOW LEAD BRASS ALLOY
4	GASKET - SEAL	NITRILE ASTM D2000
5	BODY	CAST LOW LEAD BRASS ALLOY
6	O-RING	EPDM ASTM D2000
7	END PIECE	CAST LOW LEAD BRASS ALLOY
8	PJ CTS GSKT	BUNA N ASTM D2000
9	PJ WASHER	POLYPROPYLENE
10	CLPG NUT SUB	CAST BRASS ASTM B62 ALLOY C83600

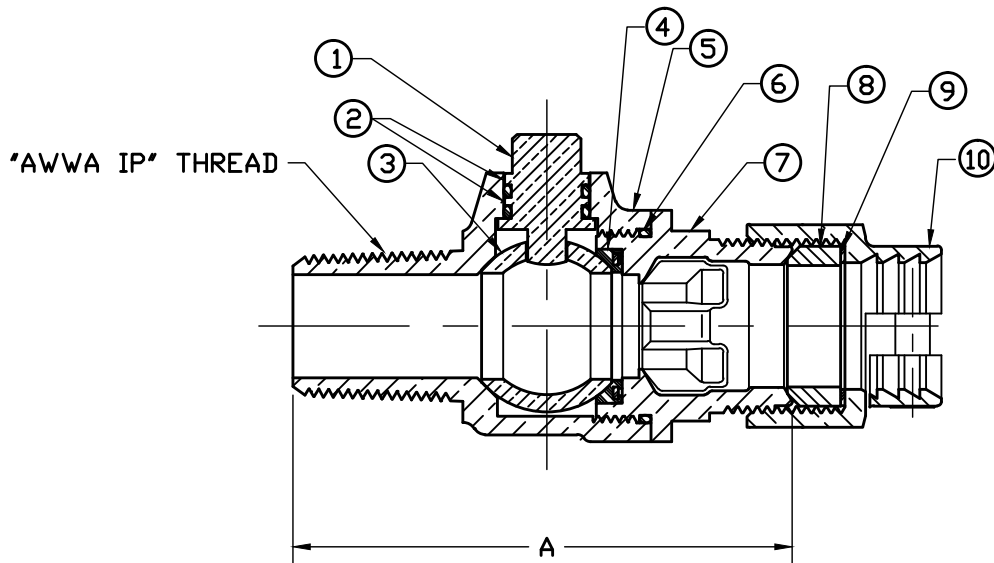

VALVE SIZE	A
3/4"	3-5/8"
1"	4-21/32"
1-1/2"	5-5/32"
2"	5-39/64"

FILEPATH: PRDD-ENG\JJ\SUBMITTALS\E1935

						DRFTR	RWB	6/9/08	JAMES JONES CO.	
						CHKR				
						ENGR				
						MGR				
							BY	DATE	UNLESS OTHERWISE NOTED	
									THIRD ANGLE PROJECTION	
									SURFACE PREPARATION:	
									BREAK CORNER(S) ---- .000	
									SURFACE FINISH -- XX RMS	
									TOLERANCE(S):	
									LINEAR ----- ± .000	
									ANGULAR ----- ± 0°00'	
									REF. No.	SCALE
									PART NUMBER	
									E1935	
REV	ECR	DESCRIPTION	DATE	BY	CHKR	DESCR.				
						BALL TYPE CORPORATION VALVE				
						('MIP" x PJ CTS)				

PART NUMBER
E1935
JJ-MRKTG