

No.	DESCRIPTION	MATERIAL
1	STEM	LOW LEAD BRASS ALLOY
2	O-RING	EPDM D2000
3	BALL	LOW LEAD BRASS ALLOY
4	GASKET - SEAL	NITRILE D2000
5	BODY	CAST LOW LEAD BRASS ALLOY
6	O-RING	EPDM D2000
7	END PIECE	CAST LOW LEAD BRASS ALLOY

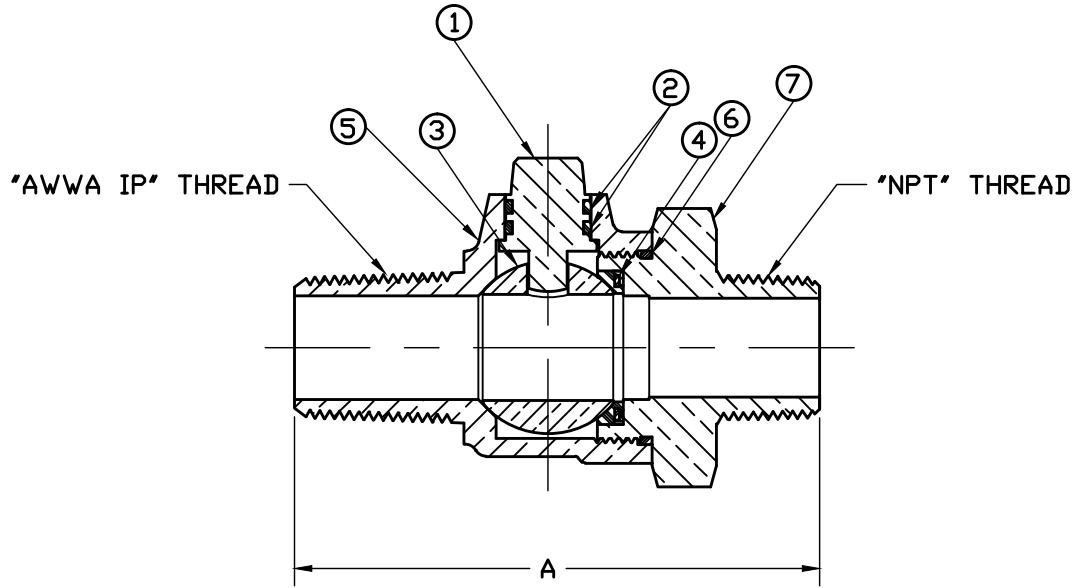

VALVE SIZE	A	NPT SIZE
3/4	3-13/16"	3/4"
1	4-33/64"	1"
1-1/2	5-53/64"	1-1/2"
2	6-13/32"	2"

FILEPATH: PROD-ENG\JJ\SUBMITTALS\E1943

						DRFTR JGarvin	8/28/09	<b>JAMES JONES CO.</b>				
						CHKR				UNLESS OTHERWISE NOTED SURFACE PREPARATION: BREAK CORNER(S) ---- .000 SURFACE FINISH -- XX RMS TOLERANCE(S): LINEAR ----- ± .000 ANGULAR ----- ± 0°00'	THIRD ANGLE PROJECTION 	
						ENGR						REF. No.    SCALE
						MGR						
						BY	DATE					
						STK No:						
						MAT'L:						
						DESCR.		BALL TYPE CORPORATION VALVE LOW LEAD BRASS ("MIP" x MIP)				
REV	ECR	DESCRIPTION	DATE	BY	CHKR				PART NUMBER E1943			

PART NUMBER  
**E1943**  
 JJ-MRKTG