

Optima Plus® Sloan Flushometer™

Sensor Flushometers

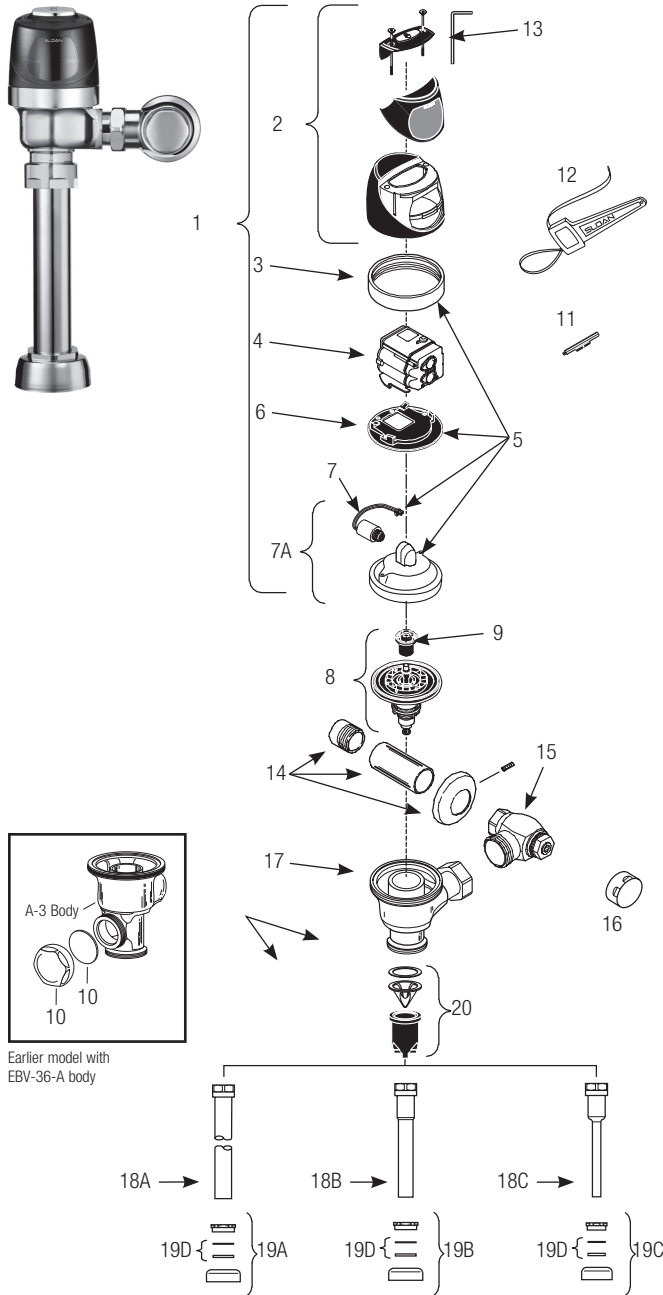

PARTS LIST

Item No.	Code No.	Part No.	Description
1.	0325298	EBV-189-A	Cover/Ring/Sensor Assembly - Water Closet
	0325299	EBV-190-A	Cover/Ring/Sensor Assembly - Urinal
	0325239	EBV-198-A	Cover/Ring/Sensor Assembly - Water Closet w/ Zurn ring
	0325240	EBV-199-A	Cover/Ring/Sensor Assembly - Urinal w/Zurn ring
2.	0325241	EBV-192-A	Cover Assembly
3.	N/A	EBV-168	Locking Ring - Plastic inner cover only – Use 3325089 , EBV-1010-A
	0305843	EBV-14	Locking Ring - Metal inner cover only
	0305843	EBV-30-A	Locking Ring - for Zurn valves
4.	3325450	EBV-129-A-C	Electronic Module - Water Closet
	3325451	EBV-129-A-U	Electronic Module - Urinal
5.	3325089	EBV-1010-A	Metal Inner Cover Repair Kit Includes Items Nos. 3, 5, 6 and 7
6.	0325171	EBV-134	Cover Rest Plate
7.	3325453	EBV-136-A	Solenoid
7A.	3325456	EBV-145-A	Inside Cover Assembly (includes solenoid EBV-136-A) Does not replace Plastic Inner Cover. Use Item No. 5
8.	SEE CHART NEXT PAGE		Flex Tube Diaphragm Assembly
9.	SEE CHART NEXT PAGE		Flush Volume Regulator
10.	0325286	EBV-186	Handle Cap Kit
11.	0325107	EBV-91	Range Adjustment Tool
12.	0305823	EBV-22	Strap Wrench
13.	0325159	EBV-137	7/64" Hex Wrench
14.	3308785	H-634-AA	1" (25 mm) Sweat Solder Kit
	3308788	H-636-AA	3/4" (19 mm) Sweat Solder Kit
15.	3308386	H-700-A	1" (25 mm) Bak-Chek® Control Stop
	3308384	H-700-A	3/4" (19 mm) Bak-Chek® Control Stop
16.	3308840	H-573-A	Stop Cap
17.	0305381PK	A-3-A	Valve Body *
18A.	5323007	V-500-AA	1-1/2" (38 mm) x 9" (229 mm) Vacuum Breaker (Model 8110/8111)
	0323014	V-500-AA	1-1/2" (38 mm) x 13 1/2" (343 mm) Vacuum Breaker (Model 8113)
	0323019	V-500-AA	1-1/2" (38 mm) x 23" (584 mm) Vacuum Breaker (Model 8115)
	0323021	V-500-AA	1-1/2" (38 mm) x 26" (660 mm) Vacuum Breaker (Model 8116)
18B.	5323006	V-500-AA	1-1/4" (32 mm) x 9" (229 mm) Vacuum Breaker (Model 8180)
18C.	5323005	V-500-AA	3/4" (19 mm) x 9" (229 mm) Vacuum Breaker (Model 8186)
19A.	0306145	F-56-A	1-1/2" Spud Coupling Assembly (Models 8110, 8115 & 8116)
19B.	0306142	F-55-A	1-1/4" Spud Coupling Assembly (Model 8180)
19C.	0306102	F-54-A	3/4" Spud Coupling Assembly (Model 8186)
19D.	SEE SLIP JOINT GASKETS AND RINGS TABLE ON NEXT PAGE		
20.	3323192	V-551-A	Vacuum Breaker Repair Kit

* Part number varies with valve model variation; consult factory.

Optima Plus® Sloan Flushometer™

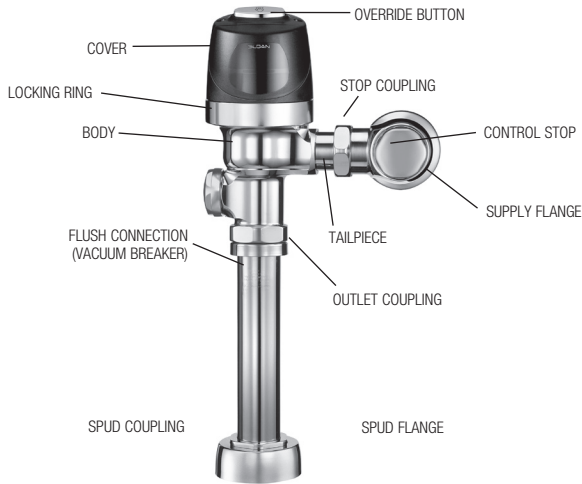

OPERATION

A continuous, INVISIBLE light beam is emitted from the Optima Plus® Sensor.

As the user enters the beam's effective range, 22 to 42 inches (559 mm to 1067 mm) for closet installations and 15 to 30 inches (381 mm to 762 mm) for urinal installations, the beam is reflected into the Scanner Window to activate the Output Circuit. Once activated, the Output Circuit continues in a "hold" mode for as long as the user remains within the effective range of the sensor.

When the user steps away, the loss of reflected light initiates an electrical "one-time" signal that activates the flushing cycle to flush the fixture. The Circuit automatically resets and is ready for the next user.

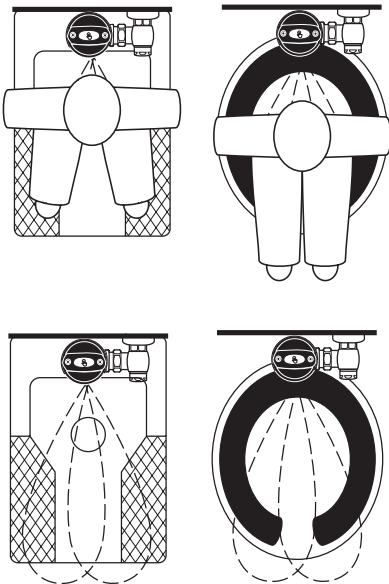

ITEM 8. FLEX TUBE DIAPHRAGM KIT

Code No.	Part No.	Description	Regulator Color *
3325150	EBV-1050-A	Urinal-0.5 gpf/1.9 Lpf	GREEN
3325151	EBV-1051-A	Urinal-1.0 gpf/3.8 Lpf †	GREEN
3325153	EBV-1053-A	Closet-1.6 gpf/6.0 Lpf †	GREEN
3325152	EBV-1052-A	Closet-2.4 gpf/9.0 Lpf	BLUE

† The EBV-1051-A and EBV-1053-A Kits are supplied with multiple Regulators.

* Color of regulator to be used with flex tube diaphragm to obtain the listed flush volume.

A 1.0 gpf (3.8 Lpf) Urinal kit can be converted to a 1.5 gpf (5.7 Lpf) Urinal by replacing the Green Regulator with the supplied Black Regulator.

A 1.6 gpf (6.0 Lpf) Closet kit can be converted to a 3.5 gpf (13.2 Lpf) Closet by replacing the Green Regulator with the supplied White Regulator.

ITEM 9. REGULATORS

The flush volume of the flex tube diaphragm kit is controlled by the regulator. Regulators are identified by color. Some flex tube diaphragm kits are supplied with multiple regulators. The installer must make sure the proper regulator is used when installing the flex tube diaphragm kit.

REGULATOR (SOLD 6 PER PACKAGE)

Code No.	Part No.	Description	Regulator Color
5325122	EBV-95	Urinal-0.5 gpf/1.9 Lpf	GREEN
5325122	EBV-95	Urinal-1.0 gpf/3.8 Lpf	GREEN
5325122	EBV-95	Closet-1.6 gpf/6.0 Lpf	GREEN
5325128	EBV-101	Closet-2.4 gpf/9.0 Lpf	BLUE

FLEX TUBE DIAPHRAGM ASSEMBLY

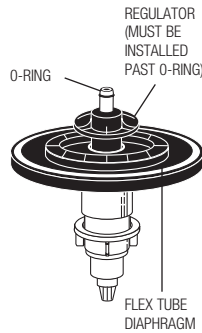

Optima Plus Valve Models Feature Sloan's Exclusive Flex Tube Diaphragm™ for the ultimate in valve performance, reliability and Chloramine resistance.

ITEM 19D. SLIP JOINT GASKETS AND RINGS

Size	Code No.	Part No.	Description
1-1/2"	5306058	F-3	Red Friction Ring
	5322001	VBF-5	Black Slip Joint Gasket
	0319086/5319086	S-30	Flexible Seat
	0319079	S-21	Rigid Seat (rubber over brass)
1-1/2" x 1-1/4"	0396062	F-105	Slip Joint Gasket – Rigid
1-1/4"	5306057	F-3	Red Friction Ring
	5322176	VBF-5	Black Slip Joint Gasket
	0307052/5307052	G-21	Rigid Seat (rubber over brass)
1"	5306056	F-3	Red Friction Ring
	5306115	F-5	Black Slip Joint Gasket
3/4"	5306055	F-3	Red Friction Ring
	5306113	F-5	Black Slip Joint Gasket

Sensor Flushometers

Optima Plus® Sloan Flushometer™

BATTERY REPLACEMENT

When required, replace batteries with four (4) Alkaline AA-Size Batteries.

Note: Water does not have to be turned off to replace batteries.

Loosen the two (2) Screws on top of unit. Remove the complete Cover Assembly. Lift the Sensor Module from its Plate. Unplug the Electrical Connector from Battery Compartment Cover. Loosen the Retaining Screw on Battery Compartment Cover and remove Battery Compartment Cover. Install four (4) Alkaline AA-Size Batteries **exactly** as illustrated.

Install Battery Compartment Cover and secure with Retaining Screw. Make certain that Battery Compartment Cover is fully compressed against Gasket to provide a seal; **Do Not** over-tighten. Plug the Electrical Connector into the Battery Compartment Cover. Reinstall the Sensor Module onto the Plate. Tighten the two (2) Screws on top of the unit.

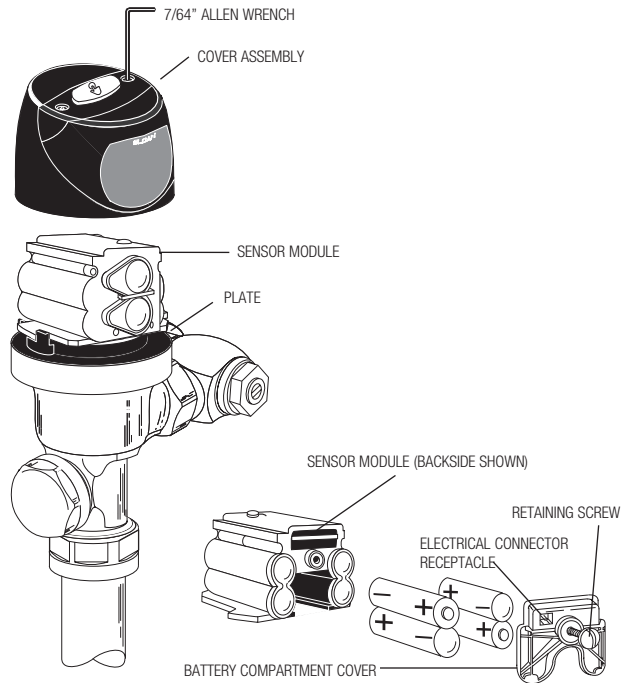

RANGE ADJUSTMENT (ADJUST ONLY IF NECESSARY)

The Optima Plus® has a factory set sensing range:

Water Closet Models - 22" to 42" (559 mm to 1067 mm)

Urinal Models - 15" to 30" (381 mm to 762 mm)

The Factory setting should be satisfactory for most installations.

If the range is too short (i.e., not picking up users) or too long (i.e., picking up opposite wall or stall door) the range can be adjusted.

Note: Water does not have to be turned off to adjust range.

Refer to Illustration on at right.

Loosen the two Screws on top of the unit. Remove the Override Button. Remove the Rubber Plug from top of Electronic Sensor Module to uncover the Potentiometer.

RANGE ADJUSTMENT PROCEDURE

For the first ten (10) minutes of operation, a Visible Red Light flashes in the Sensing Window of the Optima Plus flushometer when a user is detected. This Visible Red Light feature can be reactivated after ten (10) minutes by opening and closing the Battery Compartment Door.

Check the range by stepping toward the unit until the Red Light flashes, indicating the Sensor's maximum detection limit. Adjust the Range Potentiometer Screw located on top of the Sensor Module a few degrees **CLOCKWISE** to increase the range or a few degrees **COUNTERCLOCKWISE** to decrease the range. Repeat this adjustment until the desired range is achieved.

Always Determine the Sensing Range with Plastic Cover and Lens Window On Top of the Unit.

Important: Adjust in small increments only! Range Potentiometer Adjustment Screw rotates only 3/4 of a turn; DO NOT over-rotate.

When range adjustment is satisfactory, replace the Rubber Plug. Reinstall Override Button and tighten the two Screws on top of the unit.

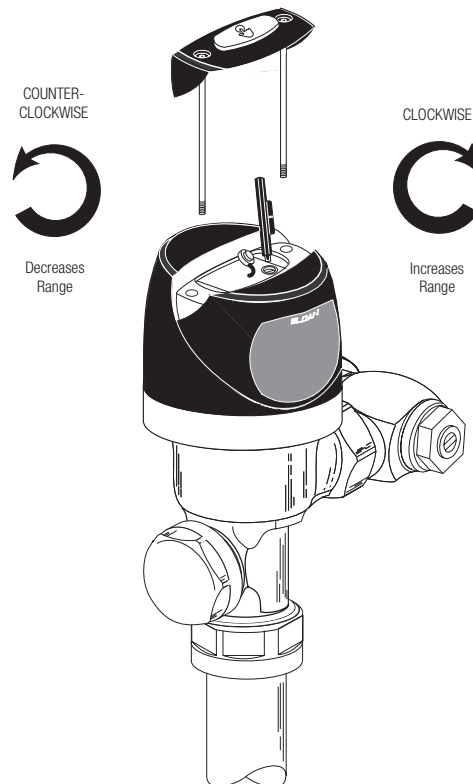

Optima Plus® Sloan Flushometer™

TROUBLESHOOTING AND MAINTAINING THE SLOAN OPTIMA PLUS® FLUSHOMETER

IMPORTANT: This product contains mechanical and/or electrical components that are subject to normal wear. These components should be checked on a regular basis and replaced as needed to maintain the valve's performance.

Never open Control Stop to where the flow from the valve exceeds the flow capability of the fixture. In the event of a valve failure, the fixture must be able to accommodate a continuous flow from the valve.

ATTENTION INSTALLERS: With the exception of the control stop inlet, DO NOT USE pipe sealant or plumbing grease on any valve component or coupling! To protect the chrome or special finish of Sloan flushometers, DO NOT USE toothed tools to install or service these valves. Use our A-50 Super-Wrench™ or other smooth-jawed wrench to secure couplings. Regulations for low consumption fixtures (1.6 gpf/6.0 Lpf closets and 1.0 gpf/3.8 Lpf urinals) prohibit use of higher flush volumes.

1. Sensor flashes continuously only when user steps within range.

A. Unit in Start-Up mode; no problem. This feature is active for the first ten (10) minutes of operation.

2. Valve does not flush; sensor not picking up user.

A. Range too short; increase the range.

3. Valve does not flush; sensor picking up opposite wall or surface, or only flushes when someone walks by. Red light flashes continuously for first 10 minutes even with no one in front of the sensor.

A. Range too long; shorten range.

4. Valve does not flush even after adjustment.

A. Range Adjustment Potentiometer set at full "max" or full "min" setting. Readjust Potentiometer away from full "max" or "min" setting.

B. Batteries completely used up; replace batteries.

C. Problem with Electronic Sensor Module; replace Electronic Sensor Module.

5. Unit flashes four (4) quick times when user steps within range.

A. Batteries low; replace batteries.

6. Valve does not shut off.

A. Bypass Orifice in Diaphragm is clogged with dirt or debris, or Bypass is clogged by an invisible gelatinous film due to "over-treated" water. Remove Flex Tube Diaphragm and wash under running water.

Note: Size of orifice in the by-pass is of utmost importance for the proper metering of water by the valve. **DO NOT ENLARGE OR DAMAGE THIS ORIFICE.** Replace flex tube diaphragm if cleaning does not correct the problem.

B. Dirt or debris fouling Stem or Flex Tube Diaphragm. Remove Flex Tube Diaphragm and wash under running water.

C. O-ring on Stem of Flex Tube Diaphragm is damaged or worn. Replace O-ring if necessary.

D. Problem with Electronic Sensor Module; replace Sensor Module.

7. Not enough water to fixture.

A. Wrong Flush Volume Regulator installed in Flex Tube Diaphragm Kit. Install the correct Regulator (see Step 6 of these instructions).

B. Wrong Optima Plus® Diaphragm kit installed; i.e., 1 gpf. urinal installed on 3.5 gal. closet fixture. Replace with proper Optima Plus diaphragm kit.

C. Enlarged Bypass in Diaphragm. Replace Flex Tube Diaphragm.

D. Control Stop not adjusted properly. Readjust Control Stop.

E. Inadequate volume or pressure at supply. Increase water pressure or supply (flow) to valve. Consult factory for assistance.

8. Too much water to fixture.

A. Wrong Flush Volume Regulator installed in Flex Tube Diaphragm Kit. Install the correct Regulator (see Step 6 of these instructions).

B. Control Stop not adjusted properly. Readjust Control Stop.

C. Wrong Optima Plus Diaphragm kit installed; i.e., 3.5 gpf. closet installed on 0.5 gal. urinal fixture. Replace with proper Optima Plus Diaphragm kit.

D. Dirt in Diaphragm Bypass. Clean under running water or replace Flex Tube Diaphragm.

CARE AND CLEANING OF CHROME AND SPECIAL FINISHES

DO NOT USE abrasive or chemical cleaners to clean flushometers as they may dull the luster and attack the chrome or special decorative finishes. Use **ONLY** soap and water, then wipe dry with clean cloth or towel.

While cleaning the bathroom tile, the flushometer should be protected from any splattering of cleaner. Acids and cleaning fluids can discolor or remove chrome plating.

When assistance is required, please contact Sloan Technical Support at: 1-888-SLOAN-14 (1-888-756-2614).